

# ASSEMBLY INSTRUCTIONS

MODEL : C8108A  
DRESSER & MIRROR

(Box 1)  
BOX OF MIRROR

NO	ITEM	QTY
A	MIRROR	1 PC
B	MIRROR SUPPORT RAIL WITH ARROW MARKING	2 PCS

(Box 2)  
BOX OF DRESSER

NO	ITEM	QTY
C	DRESSER	1 PC

(Box 1)  
HARDWARE LIST

NO	ITEM	QTY
1	JCBC BOLT M6 x 35MM BLK	4 PCS
2	JCBC BOLT M6 x 40MM BLK	4 PCS
3	SPRING WASHER 1/4" RBW	8 PCS
4	FLAT WASHER 1/4" ID x 19mmOD BLK	8 PCS
5	ALLEN KEY m4 x 65mm BLK	1 PC

STEP 1 : Draw out mirror support (B) from the carton box.

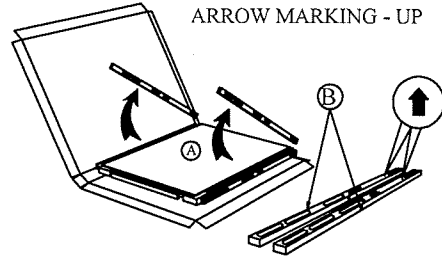

STEP 2 : Align & fasten mirror support (B) to the back of mirror (A) using short JCBC bolt(1), spring washer (3) & flat washer (4). DO NOT FULLY TIGHTEN AT THIS STEP.

Note : Make sure arrow marking of the mirror support (B) is aligned up.

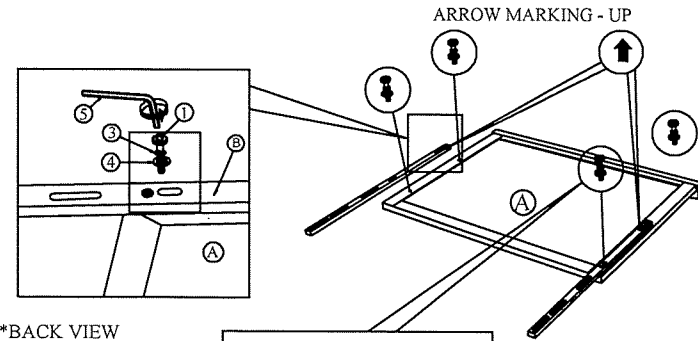

\*\*BACK VIEW

WARNING !  
USE SHORT BOLT M6 x 35mm

STEP 3 :

Place mirror (A) on top of dresser (C). Align & fasten mirror support (B) to the back of dresser (C) using long JCBC bolt (2) , spring washer (3) & flat washer (4) THEN FULLY TIGHTEN ALL THE BOLTS AT STEP 2 & 3 WITH ALLEN KEY ( 5 ).

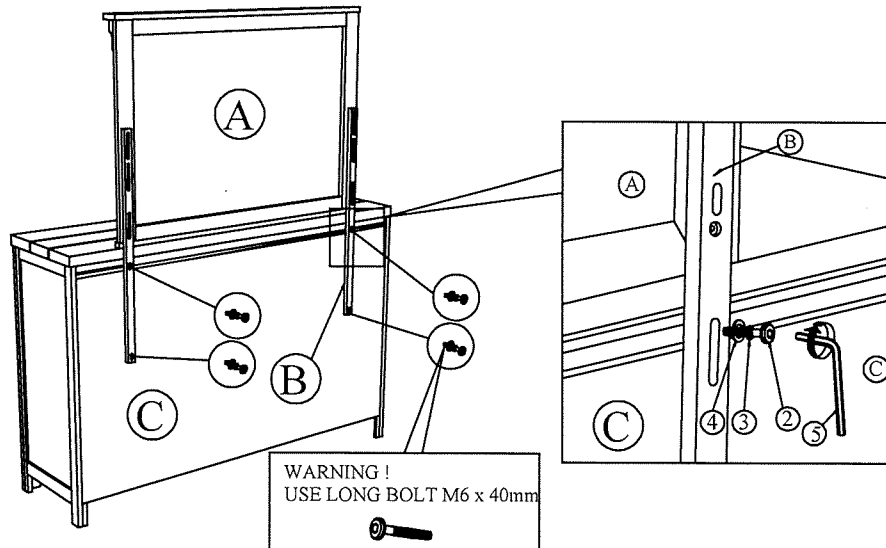

WARNING !  
USE LONG BOLT M6 x 40mm

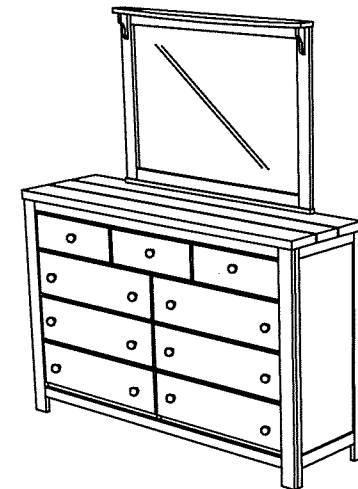



**COMPLETED  
ASSEMBLY**

NOTE : MUST TIGHTEN SCREWS PERIODCALLY WITH USE SCREW WILL BECOME LOOSE CHECK TIGHTNESS OF ALL SCREW EVERY 6-8 WEEKS.

# INSTRUCTIONS D'ASSEMBLAGE

MODÈLE: C8108A  
COMMODE & MIROIR



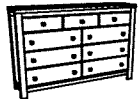

(Cart. 1)  
CARTON MIROIR

N°	PIÈCE	QTE
A	MIROIR 	1 PCE
B	RENFORT DU MIROIR 	2 PCES

(Cart. 2)  
CARTON COMMODE

N°	PIÈCE	QTE
C	COMMODE 	1 PCE

(Cart. 1)  
QUINCAILLERIE

N°	PIÈCE	QTE
1	BOULON JCBC M6 x 35MM BLK 	4 pces
2	BOULON JCBC M6 x 40MM NRE 	4 pces
3	RONDELLE A RESSORT 1/4" RBW 	8 pces
4	RONDELLE PLATE 1/4" DI x 19mm DE NRE 	8 pces
5	CLÉ ALLEN m4 x 65mm NRE 	1 pce

ETAPE 1 : Enlever les renforts du miroir ( B ) du carton.

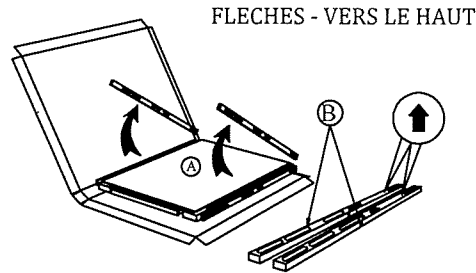

ETAPE 2 : Aligner et attacher les renforts ( B ) à l'arrière du miroir ( A ) en utilisant le boulon JCBC ( 1 ), rondelle à ressort ( 3 ) & rondelle plate ( 4 ). SERRER LES BOULONS AVEC LA CLE ALLEN. NE PAS SERRER COMPLETEMENT LORS DE CETTE ETAPE. Remarque : S'assurer que les fleches du renforts ( B ) pointent vers le haut.

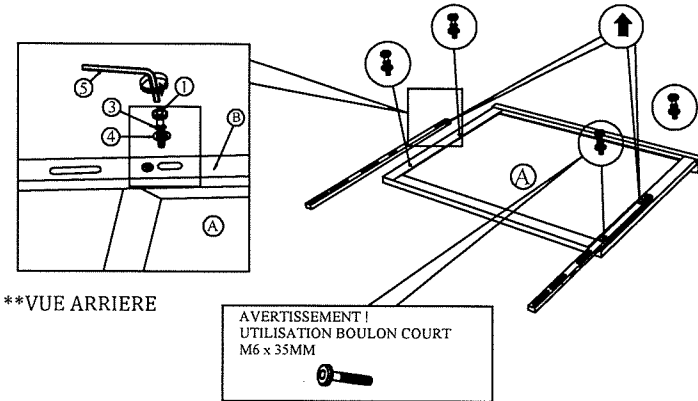

ETAPE 3 : Poser le miroir ( A ) sur la commode ( C ). Aligner et attacher le renfort ( B ) à l'arrière de la commode ( B ) en utilisant le boulon JCBC ( 2 ), rondelle à ressort ( 3 ) & rondelle plate ( 4 ). PUIS, SERRER TOUS LES BOULONS DES ETAPES 2 & 3 AVEC LA CLE ALLEN ( 5 ).

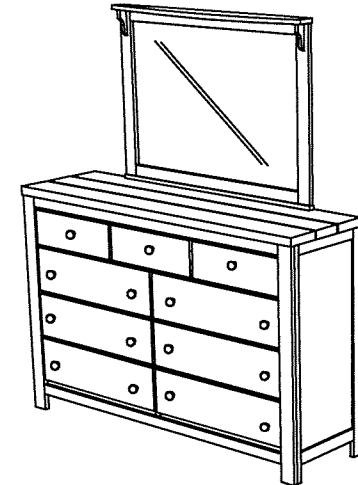
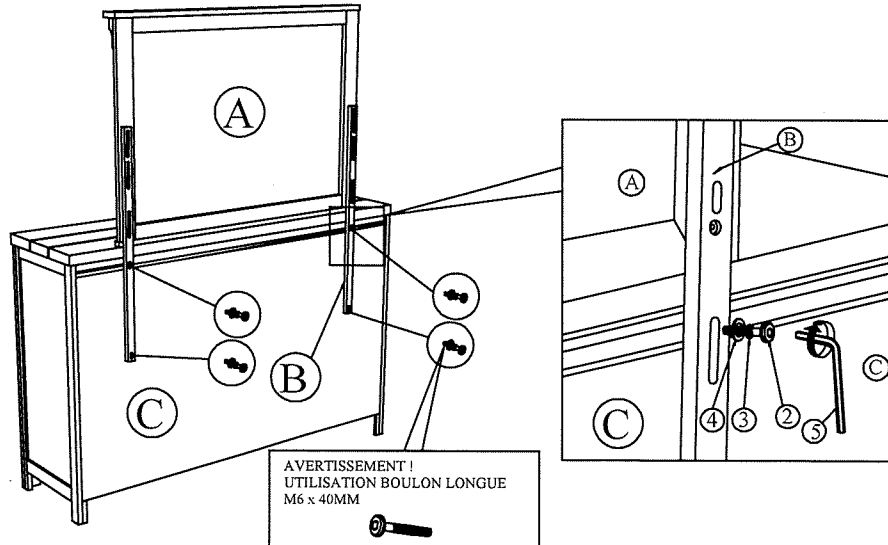

**ASSEMBLAGE TERMINÉ**

REMARQUE : RESERRER LES VIS RÉGULIÈREMENT. À L'USAGE, LES VIS SE DESERRENT. VÉRIFIER QUE LES VIS SOIENT SERRÉES TOUTES LES 6-8 SEMAINES.