

Features and Specifications:

- Double equal bowl kitchen sink.
- Made of 80% quartz and the finest acrylic resins.
- Designed for undermount installation in all solid surface, granite and quartz countertops.
- Outside dimensions: 32-1/2" x 19-1/2" x 9".
- Inside bowl dimensions:
 Left bowl - 14-1/2" x 15-3/4" x 9"
 Right bowl - 14-1/2" x 15-3/4" x 9"
- Rear positioned wastes.
- Waste opening: 3-1/2".
- Sink bowl surface has a matte finish.
- Supplied with mounting clips and cutout template.
- Strainer baskets shown not included with sink.
- Strainer baskets in stainless steel or matching colors available as optional accessories.
- Sinks colors available: Black, Bisque, White, Concrete, Brown, Grey
- cUPC Certified

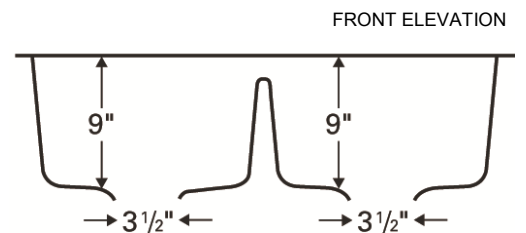
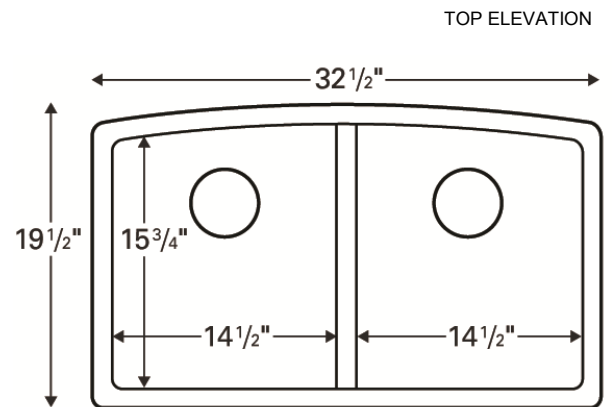

ALL DIMENSIONS ACCURATE TO 1/4"