

## NOVUS SERIES

# 10mm Radius Undermount Large Single Bowl

Sliding Dual Platforms System

**Model : NVS-6500**



### FEATURES

- Premium grade T-304 stainless steel
- 10" depth • 18 gauge
- Totalguard+ insulation
- Brushed satin, rear-set drain
- 3-1/2" drain opening
- Fits 48" sink base
- Supplied with cutout template, fasteners and instructions
- Includes : Glass Cutting Board, two Drying Trays, Multi-Purpose Roll-Up Mat, Two Bottom grids, Stainless Steel Basket Strainer.
- Lifetime Limited Warranty



**TYPE 304**  
PREMIUM STAINLESS STEEL

**MEGA SHIELD**  
INSULATION

**SUPER SILENCER**

**Lifetime Warranty**

### OPTIONAL ACCESSORIES

Bottom Grid: BG-4901, BG-4902 Drying Tray: DT-4230, DT-1300  
Cutting Board : GB-4800 Roll-Up Mat: RO-1600  
Strainer: 190-9180

OVERALL DIMENSIONS	EACH BOWL	CUTOUT SIZE	PACKAGING*	WEIGHT*
45" x 17-13/16"	43-7/16" x 14-1/4"	See Template	1/12 pcs.	45/580 lbs.

\*Standard packaging: Single boxed /Pallet of single boxed.  
All dimensions are in inches. Specifications subject to change without notice.

Project/Job name \_\_\_\_\_

Architect/Engineer \_\_\_\_\_

Contractor \_\_\_\_\_

Model \_\_\_\_\_

Q'ty \_\_\_\_\_

Notes \_\_\_\_\_

NVS-6500

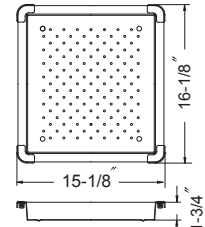
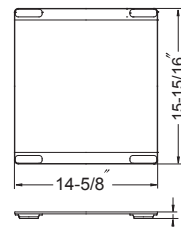
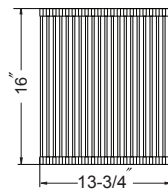
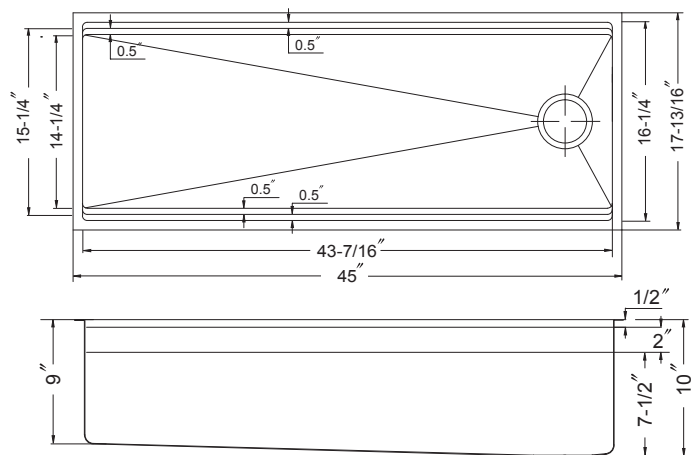

### Installation profile

