

# GUARDAIR®

## OPERATING INSTRUCTIONS

FOR GUARDAIR STANDARD, NED AND PULSEAIR™ COMPRESSED AIR-POWERED VACUUMS

**Please save these instructions and the accompanying replacement parts information for your future reference.**

### FOR YOUR SAFETY

Turn off all compressed air connections with the compressed air source at the nearest valve. Disconnect compressed air connections only after the compressed air supply has been turned off and the air supply hose vented by opening the valve on the vacuum head. NEVER disconnect a pressurized compressed air hose.

### AIR SUPPLY

An adequate supply of compressed air is essential for the proper performance of your Guardair vacuum. Compressed air requirements for vacuum units and vacuum generating heads equipped with the following Venturi types are listed below:

#### “Dual B” Venturi

N552B Series..... 110 cfm

#### “B” Type Venturi

N551B Series, N301B Series .....68 cfm

#### “D” Type Venturi

N551D Series, N301D Series, N201DC, N101DC .....47 cfm

#### “S” Type Venturi

N201SC, N101SC .....20 cfm

#### “M” Type Venturi

N101MC, N051MC.....20 cfm

Please note that these requirements are for compressed air volume, not pressure. The recommended compressed air inlet operating pressure is 100 psi for all vacuum units. All units will function at lower operating pressures, but with a corresponding reduction in performance.

Units featuring a “B” or “D” Type Venturi include a Chicago-style connector. A 3/4” ID or larger compressed air supply hose is recommended for these models.

Units featuring an “S” Type Venturi include a 1/2” industrial interchange male connector. A 1/2” ID

or larger compressed air supply hose is recommended for these models. Units featuring an “M” Type Venturi include a 3/8” industrial interchange male connector. A 3/8” ID or larger compressed air supply hose is recommended for these models.

**FOR ALL MODELS:** To ensure maximum performance, clean or replace the internal filter as necessary. In addition, clean or replace the exhaust silencer (inside the exhaust housing) as necessary. Inspect the cover gasket for deterioration and replace if necessary. On all vacuum units, use of a smaller diameter air hose or smaller size air fittings will seriously restrict performance. Use the recommended hoses and fittings.

Be certain that the drum has no dents along the seams and is airtight. The cover gasket under the vacuum generating head must form a complete seal with the top edge of the drum.

**CAUTION: Drums used with Guardair vacuum generating heads must meet the steel gauge requirements in the table below. Thinner gauges of steel run the risk of drum collapse.**

DRUM	55 gal	30 gal	20 gal	10 gal	5 gal
GAUGE	19	18	18	20	20

### REPLACING GASKETS

**On 55, 30 & 20 Gallon Models,** remove the gasket to be replaced. On the new gasket, remove the protective tape covering the adhesive, then apply gasket to lid.

**On 10 & 5 Gallon Models,** the lid gasket is adhered to the lid by hot glue. The hot glue can easily be removed with rubbing alcohol. Let the rubbing alcohol sit for one minute, then simply peel off with a flat head screwdriver. We recommend using hot glue when installing new gasket.

## SET-UP AND OPERATION, 55-GALLON, 30-GALLON AND 20-GALLON MODELS:

Place the vacuum generating head on the drum. There are no clamps required to form an airtight seal. When the vacuum is in operation, the negative pressure within the drum will create the airtight seal between the head and drum.

Connect the vacuum hose to the vacuum generating head by inserting the hose adapter into the inlet elbow. Slip the hose end onto the adapter. Connect vacuum attachments to the vacuum hose.

Turn off the compressed air supply valve at the compressor.

### B & D Venturis

Connect the compressed air supply hose to the vacuum generating head via the Chicago-style coupler. Twist together and be sure they lock. Install the safety clips. Connect the compressed air supply hose to the compressor. Turn on the compressed air supply. Open the shut-off valve to operate.

### S Venturis

Connect the compressed air supply hose to the vacuum generating head via the 1/2" industrial interchange male connector. Connect the compressed air supply hose to the compressor. Turn on the compressed air supply. Open the shut-off valve to operate.

### Liquid Shut-off Accessory

Before picking up liquids, remove the internal filter, which is held in place by three springs. For continuous liquid pick-up, the liquid shut-off accessory (optional) should be installed in place of the internal filter and held in place by the same three springs.

**55 & 30 Gallon Drum Dolly** Assemble the drum dolly for 55-gallon and 30-gallon models as shown below.

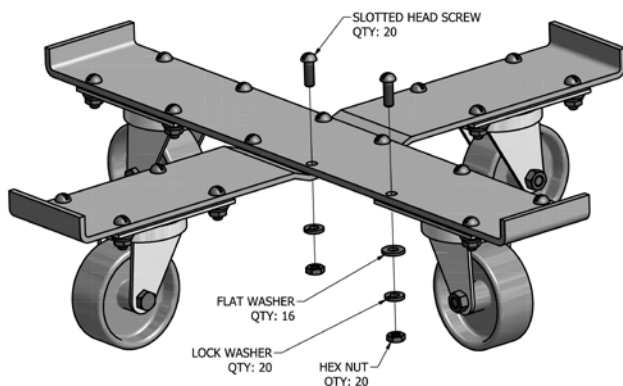

**Caution: Dolly maximum load capacity is 1,000 pounds.**

**20 Gallon Drum Dolly:** Assemble the drum dolly for 20-gallon model as shown below (Compatible with 30 gallon).

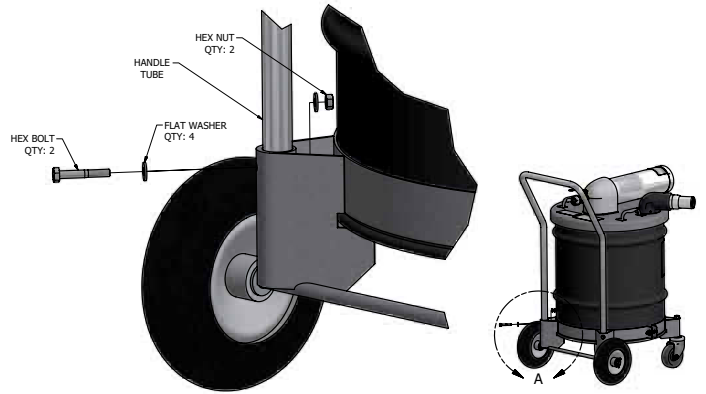

**Caution: Dolly maximum load capacity is 1,000 pounds.**

## SET-UP & OPERATION, 10-GALLON MODELS:

The vacuum generating head, which mounts on top of the drum, seals to the drum via the lid clamps.

Connect the vacuum hose to the vacuum hose inlet by slipping the hose end onto the connector. This is an intentionally tight fit. Connect vacuum attachments to the vacuum hose.

The vacuum comes with a liquid shutoff assembly built internally within the cartridge filter. The cartridge filter can be removed for maintenance or replacement by removing the wing nut and washer on the bottom of the filter.

Turn off the compressed air supply valve at the compressor.

**Model N101DC** - Connect the compressed air supply hose to the vacuum generating head via the Chicago-style coupler. Twist together, making sure that they lock. Install the safety clips. Connect the compressed air supply hose to the compressor. Turn on the compressed air supply. Open the shut-off valve to operate.

**Model N101SC** - Connect the compressed air supply hose to the vacuum generating head via the 1/2" industrial interchange male connector. Connect the compressed air supply hose to the compressor. Turn on the compressed air supply. Open the shut-off valve to operate.

**Model N101MC** - Connect the compressed air supply hose to the vacuum generating head via the 3/8" industrial interchange male connector. Connect the compressed air supply hose to the compressor. Turn on the compressed air supply. Open the shut-off valve to operate.

### **SET-UP & OPERATION, 5-GALLON MODELS:**

The vacuum generating head, which mounts on top of the drum, seals to the drum via the lid clamps.

Connect the vacuum hose to the vacuum hose inlet by slipping the hose end onto the connector. This is an intentionally tight fit. Connect vacuum attachments to the vacuum hose.

The vacuum comes with a liquid shutoff assembly built internally within the cartridge filter. The cartridge filter can be removed for maintenance or replacement by removing the wing nut and washer on the bottom of the filter.

Turn off the compressed air supply valve at the compressor.

Connect the compressed air supply hose to the vacuum generating head via the 3/8" industrial interchange male connector. Connect the compressed air supply hose to the compressor. Turn on the compressed air supply. Open the shut-off valve to operate.

### **STATIC CONDUCTIVE MODELS:**

Guardair manufactures NED (non-electrical discharge) models, designed to eliminate static electricity by incorporating static conductive components to suppress static electricity charges. Should stray static charges become generated, these charges are immediately dissipated through the electrically interconnected, static conductive components. For an added measure of protection, users can ground the vacuum by connecting the grounding lug to an external electrical ground using a grounding clamp and cable (available as an accessory item).

To ensure proper electrical bonding (connectivity between components), make sure that only static conductive, factory-supplied parts and accessories are used with Guardair NED vacuums. All components must fit together firmly, including the static conductive vacuum hose, which must mount securely on the vacuum hose inlet, and all static conductive vacuum accessories.

Always inspect all static conductive vacuum components before use, and replace worn or rusted parts as needed.

If you have questions about the necessity for grounding, consult with a qualified safety engineer.

### **PULSEAIR™ MODELS:**

PulseAir Vacuums/Dust Extractors incorporate proprietary PulseAir technology engineered to clean the vacuum filter without routinely opening the unit. By activating the PulseAir System, a burst of compressed air is injected into the interior of the filter mounted beneath the vacuum lid. Dust particles clogging the outer filter surface are dislodged and settle within the closed container.

In addition to automatic filter cleaning, PulseAir Vacuums/Dust Extractors are equipped with HEPA filtration to comply with **OSHA Silica Dust Regulation 29 CFR 1926.1153**. PulseAir Vacuums/Dust Extractors also come standard with a cloth pre-filter bag to provide enhanced filter protection and extend filter life, as well as static conductive components to eliminate nuisance shocks.

**Operation:** Connect PulseAir Vacuum/Dust Extractor to compressed air source using air supply hose provided. Switch ball valve to **OFF** position by turning 90 degrees clockwise. Locate button on PulseAir System beneath venturi housing on top of vacuum lid. To activate, press button and release. Depending upon filter age and surface dust concentration, pressing button between two (2) and ten (10) times should be sufficient to clean filter. Wait at least two (2) seconds between each press for system to reload.

***IMPORTANT - Do not activate PulseAir System when vacuum is in operation. Only activate when four (4) latches clamping vacuum lid to vacuum drum are secure. PulseAir Vacuums/Dust Extractors do not include a liquid shutoff device. Vacuuming liquids is therefore not recommended.***

**Replacing Cartridge Filter:** Unsecure latches. Remove pre-filter bag by disengaging the worm gear clamp. Detach three (3) retaining springs from cartridge filter cage and from vacuum lid. Gently remove pre-filter bag and cartridge filter. Do not shake pre-filter bag or cartridge filter to avoid releasing and spreading dust and containments. Also check interior of the cloth pre-filter bag and empty out dust and debris if necessary.

Fit fresh cartridge filter underneath vacuum lid. Attach one end of each retaining spring to filter cage and opposite end to ring under vacuum lid. After filter is secured in place, slide pre-filter bag over cartridge filter and fasten with worm gear clamp. Place vacuum lid on top of vacuum drum and re-fasten latches.

**PulseAir™ Dust Extractors:** Designed specifically for point-of-source dust collection applications or source capture power tools. Connect vacuum hose via hose cuff to dust port outlet on the power tool. Additional hose cuff sizes are available to provide proper dust port connectivity.

# WARRANTIES



**GUARDAIR PULSEAIR VACUUMS OFFER A ONE-YEAR LIMITED WARRANTY**

**GUARDAIR PULSEAIR DUST EXTRACTORS OFFER A ONE-YEAR LIMITED WARRANTY**

**GUARDAIR ATEX CERTIFIED VACUUMS OFFER A TWO-YEAR LIMITED WARRANTY**

**GUARDAIR STANDARD VACUUMS OFFER A FOREVER WARRANTY**

**GUARDAIR NED VACUUMS OFFER A FOREVER WARRANTY**



## LIMITED WARRANTY:

Guardair Corporation ("Guardair") warrants that, under normal use, our products are free from defects in materials or workmanship for a period of one year from date of shipment. During the warranty period, Guardair will, at our discretion and at no extra cost, repair or replace defective products or parts, or refund the purchase price. This Limited Warranty extends only to products that are purchased either directly from Guardair or from an authorized Guardair Distributor. Furthermore, the Limited Warranty extends only to products which are used for their intended purpose. This Limited Warranty does not extend to any product which has been misused, or that has been damaged from accident or mistreatment, from the use of parts not supplied by Guardair, or from modification or servicing of the product by anyone other than Guardair or its authorized Distributor.

**THE FOREGOING LIMITED WARRANTY OF GUARDAIR CORPORATION IS IN LIEU OF ALL OTHER WARRANTIES OF GUARDAIR CORPORATION, EXPRESSED OR IMPLIED, WITH RESPECT TO THE PRODUCT, INCLUDING WITHOUT LIMITATION WARRANTIES OF MERCHANTABILITY OR FITNESS FOR A PARTICULAR PURPOSE. GUARDAIR CORPORATION EXPRESSLY DISCLAIMS ALL WARRANTIES NOT STATED IN THIS LIMITED WARRANTY. IN NO EVENT SHALL GUARDAIR CORPORATION BE LIABLE FOR ANY INDIRECT, SPECIAL OR CONSEQUENTIAL DAMAGES IN CONNECTION WITH THIS PRODUCT.**

The purchaser may have certain statutory rights, as a consumer, or otherwise, to which the exclusions set forth in this Limited Warranty do not apply.

## FOREVER WARRANTY:

Guardair Corporation ("Guardair") warrants its compressed air-powered vacuums are free from defects in materials and workmanship for as long as the original end-user purchaser owns the product, except as provided below. Guardair will, at its option, repair or replace with a comparable product, any product, part, or component that fails under normal use as a result of such defect. This warranty does not apply to damage caused by the carrier; normal wear and tear; deterioration due to solvents, corrosives, environmental conditions, or harsh vacuumed material; soiling, saturation, or perforation of filters or exhaust silencers; consumable components; modifications to the product; attachments to the product not sold by Guardair; or any product not installed, used, or maintained in accordance with the foregoing and other published Guardair instructions and warnings.

Consumables purchased from Guardair including attachments, vacuum hose, filters, exhaust silencers, and cover gaskets are warranted for a period of 90 days against defects in materials and workmanship, subject to the same exclusions noted above.

This warranty covers the original purchase of a new product by an end-user for normal industrial or commercial use only when installed and used as specified and in accordance with published operating instructions and within all applicable regulatory rules, limits, and guidelines.

**THIS WARRANTY IS THE ONLY WARRANTY MADE BY GUARDAIR FOR THIS PRODUCT, AND ALL OTHER WARRANTIES, EXPRESS OR IMPLIED, INCLUDING BUT NOT LIMITED TO THE IMPLIED WARRANTIES OF MERCHANTABILITY AND FITNESS FOR A PARTICULAR PURPOSE, ARE DISCLAIMED.**

Guardair's sole obligation and the end-user purchaser's exclusive remedy under this warranty shall be limited to the repair or replacement, at the sole discretion of Guardair, of product or components. In no event shall Guardair be responsible for special, consequential, or incidental damages arising out of a claim for a defective product or failure of warranty. All labor and material costs of repair or replacement under this warranty shall be the responsibility of Guardair. Shipping costs to and from the purchaser associated with repair or replacement under this warranty shall be the responsibility of Guardair for a period of one year from the date of sale, and shall be the responsibility of the purchaser thereafter.

This warranty applies to purchasers within and products used within the United States and Canada only.

To obtain service under this warranty, within 30 days of the discovery of the defect, the end-user purchaser must contact the dealer or distributor from whom the product was purchased, or contact Guardair at the address shown below. The purchaser must provide a reasonable opportunity for inspection and investigation of the claim, prior to any repairs or alteration to the product. Until the claim is resolved, the purchaser must discontinue use of the product if continued use creates or exacerbates problems associated with, or incidental to, the defect.

Proof of purchase will be verified by the selling party and applicability of the warranty will be determined by Guardair. Guardair will determine whether to provide replacement parts, provide repair service, or replace the product. Written approval from Guardair must be obtained before any warranty work is performed. Any repairs performed by persons other than Guardair or its authorized dealers or distributors will void this warranty.

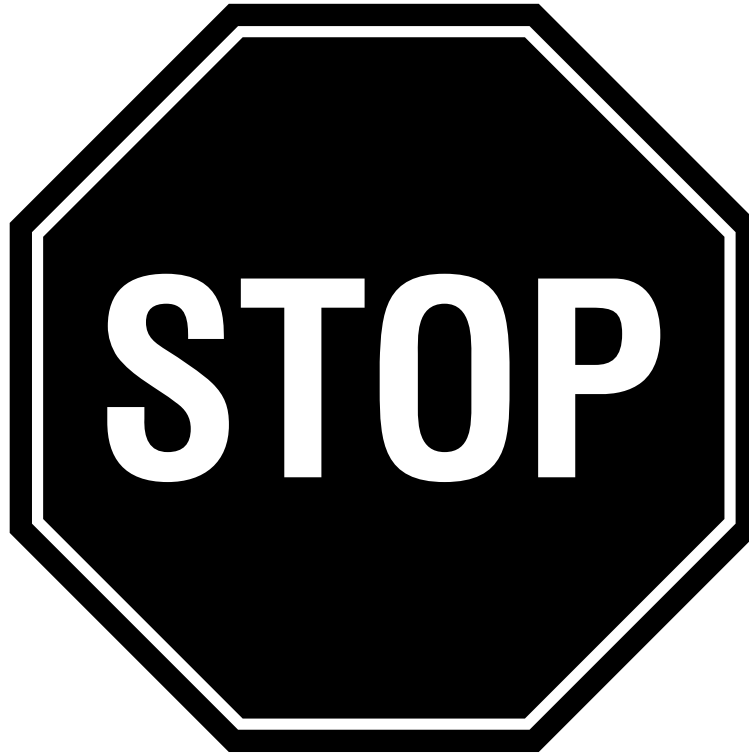

# **DO NOT RETURN THIS PRODUCT TO PLACE OF PURCHASE!**

**For problems pertaining to the operation of this vacuum unit,  
contact Guardair Corporation Customer Service at (800) 482-7324.**

**Should this vacuum need to be returned to the factory, and if a return has been pre-authorized by Guardair, the unit MUST be in original condition. Returns will not be accepted unless received in the original packaging and accompanied by the original accessories. If the vacuum has been used, the unit MUST be emptied and cleaned before shipping. In addition, a Material Safety Data Sheet (MSDS) for all materials previously vacuumed by the unit MUST be supplied to Guardair at the time of shipment.**

# PARTS LISTS

## 55 AND 30 GALLON SINGLE VENTURI VACUUM KIT

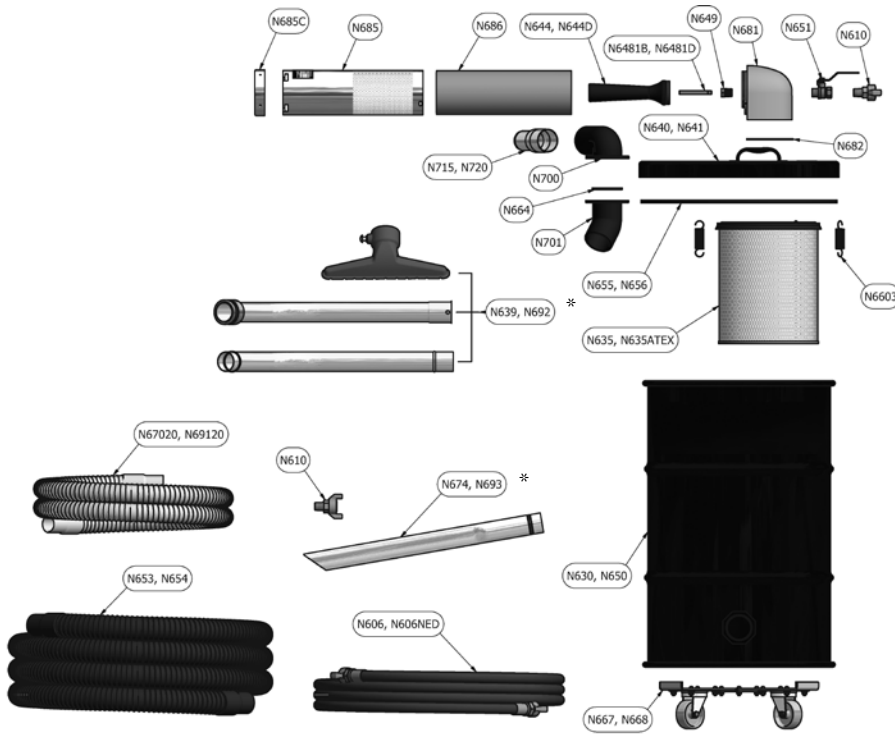

Part Number	Description
N606	3/4" ID X 20' Air Supply Hose
N606NED	3/4" ID X 20' Static Conductive Air Supply Hose
N610	1/2" NPT Chicago Coupler
N630	30 Gallon Steel Drum
N635	Standard Cartridge Filter For 30/55 Gallon Vacuums
N635ATEX	ATEX Bonded Cartridge Filter
N639	12" Wide Aluminum Floor Tool With 4' Steel Double Curved Wand For 2" Vacuum Hose
N640	Lid For 30 Gallon Drum
N641	Lid For 55 Gallon Drum
N644	B Series Venturi
N644D	D & S Series Venturi
N6481B	B Series Orifice
N6481D	D Series Orifice
N649	1/2" X 1/8" NPT Brass Hex Reducing Bushing For Air Jet
N650	55 Gallon Steel Drum
N651	Brass Shut-Off Valve For Single Venturi Models
N653	1 1/2" X 20' Static Conductive Vacuum Hose
N654	2" X 20' Static Conductive Vacuum Hose
N655	30 Gallon Vacuum Lid Gasket
N656	55 Gallon Vacuum Lid Gasket
N6603	Retaining Spring (Set of 3)
N664	Elbow Gasket
N667	30 Gallon Dolly Assembly
N668	55 Gallon Dolly Assembly
N67020	2" X 20' Standard Duty Vinyl Vacuum Hose
N674	24" Steel Crevice Tool For 2" Vacuum Hose
N681	Venturi Box
N682	Venturi Box Gasket
N685	Exhaust Housing-Long
N686	Exhaust Silencer Foam Insert
N69120	1 1/2" X 20' Standard Duty Vinyl Vacuum Hose
N692	12" Wide Aluminum Wet/Dry Floor Tool Kit For 1 1/2" Vacuum Hose
N693	24" Aluminum Crevice Tool For 1 1/2" Vacuum Hose
N700	Inlet Elbow For 30/55 Gallon Vacuums
N701	Discharge Elbow For 30/55 Gallon Vacuums
N715	1 1/2" Vacuum Hose Adapter
N720	2" Vacuum Hose Adapter

## 55 AND 30 GALLON DUAL VENTURI VACUUM KIT

Part Number	Description
N606	3/4" ID X 25' Air Supply Hose
N606NED	3/4" ID X 25' Static Conductive Air Supply Hose
N635	Standard Cartridge Filter For 30/55 Gallon Vacuums
N635ATEX	ATEX Bonded Cartridge Filter
N639	12" Wide Aluminum Floor Tool With 4' Steel Double Curved Wand For 2" Vacuum Hose
N641	Lid For 55 Gallon Drum
N644	B Series Venturi
N646	Brass Shut-Off Valve For Dual Venturi Models
N647	3/4" NPT Chicago Coupler
N6481B	B Series Orifice
N649	1/2" X 1/8" NPT Brass Hex Reducing Bushing For Air Jet
N650	55 Gallon Steel Drum
N653	1 1/2" X 20' Static Conductive Vacuum Hose
N654	2" X 20' Static Conductive Vacuum Hose
N656	55 Gallon Vacuum Lid Gasket
N6603	Retaining Spring (Set of 3)
N664	Elbow Gasket
N668	55 Gallon Dolly Assembly
N67020	2" X 20' Standard Duty Vinyl Vacuum Hose
N674	24" Steel Crevice Tool For 2" Vacuum Hose
34H07	Nipple, 3/4" NPT Fully Threaded, Schedule 40, Steel
N682X02	Dual Head Venturi Box
N682	Venturi Box Gasket
N685	Exhaust Housing-Long
N685C	Exhaust Housing End Cap
N686	Exhaust Silencer Foam Insert
N69120	1 1/2" X 20' Standard Duty Vinyl Vacuum Hose
N692	12" Wide Aluminum Wet/Dry Floor Tool Kit For 1 1/2" Vacuum Hose
N693	24" Aluminum Crevice Tool For 1 1/2" Vacuum Hose
N700	Inlet Elbow For 30/55 Gallon Vacuums
N701	Discharge Elbow For 30/55 Gallon Vacuums
N715	1 1/2" Vacuum Hose Adapter
N720	2" Vacuum Hose Adapter

\*Not included in PulseAir Dust Extractor Kits

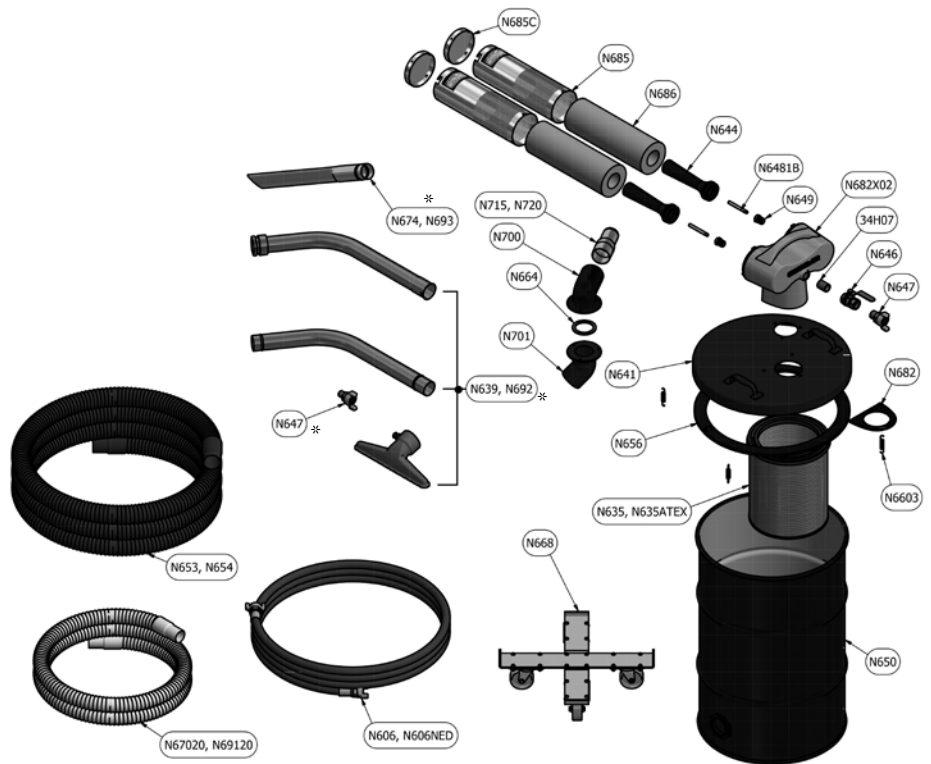

\*Not included in PulseAir Dust Extractor Kits

## 20 GALLON VACUUM KIT

Part Number	Description
N200	20 Gallon Drum
N204	20 Gallon Dolly
N606	3/4" ID X 20' Air Supply Hose
N606NED	3/4" ID X 20' Static Conductive Air Supply Hose
N607	1/2" ID X 20' Air Supply Hose
N607NED	1/2" ID X 20' Static Conductive Air Supply Hose
N610	1/2" NPT Chicago Coupler
N6182	1/2" NPT - 1/2" Male Us Industrial Interchange Coupler
N635	Standard Cartridge Filter
N635ATEX	ATEX Bonded Cartridge Filter
N640	20 Gallon Lid
N644D	D & S Series Venturi
N6481D	D Series Orifice
N6481S	S Series Orifice
N649	1/2" X 1/8" NPT Brass Hex Reducing Bushing for Air Jet
N651	Brass Shut-Off Valve for Single Venturi Models
N653	1 1/2" X 20' Static Conductive Vacuum Hose
N655	30 Gallon Lid Gasket
N6603	Retaining Spring (Set of 3)
N664	Elbow Gasket
N681	Venturi Box
N682	Venturi Box Gasket
N685	Exhaust Housing-Long
N685C	Exhaust Housing End Cap
N686	Exhaust Silencer Foam Insert
N69120	1 1/2" X 20' Standard Duty Vinyl Vacuum Hose
N692	12" Wide Aluminum Wet/Dry Floor Tool Kit For 1 1/2" Vacuum Hose
N693	24" Aluminum Crevice Tool For 1 1/2" Vacuum Hose
N700	Inlet Elbow
N701	Discharge Elbow
N715	1 1/2" Vacuum Hose Adapter

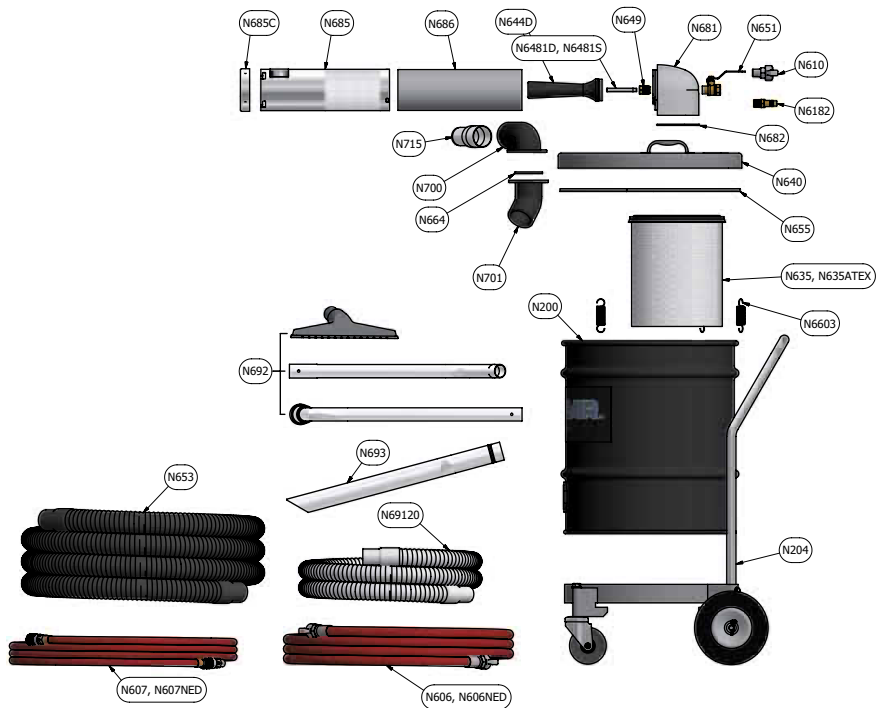

## 10 GALLON VACUUM KIT (N101DC AND N101SC MODELS)

Part Number	Description
2000F01	Filter
2000M02	Liquid Shut Off Cage
N053	5 and 10 Gallon Lid
N053Q	Vacuum Inlet Gasket
N054Q	5 and 10 Gallon Lid Gasket
N100	10 Gallon Canister With Lid Clamps and Handles
N104	1 1/2" Vacuum Inlet
N606	3/4" ID X 20' Air Supply Hose
N607	1/2" ID X 20' Air Supply Hose
N610	1/2" NPT Chicago Coupler
N6182	1/2" NPT X 1/2" Male US Industrial Interchange Coupler
N6381	Liquid Shut Off Ball
N644D	D and S Series Venturi
N6481D	D Series Orifice
N6481S	S Series Orifice
N649	1/2" X 1/8" NPT Brass Hex Reducing Bushing For Air Jet
N651	Brass Shut-Off Valve for Single Venturi Models
N681	Venturi Box
N682	Venturi Box Gasket
N685	Exhaust Housing-Long
N685C	Exhaust Housing End Cap
N686	Exhaust Silencer Foam Insert
N69120	1 1/2" X 20' Standard Duty Vinyl Vacuum Hose
N692	12" Wide Aluminum Wet/Dry Floor Tool Kit For 1.5" Vacuum Hose
N693S	11" Aluminum Crevice Tool For 1 1/2" Vacuum Hose

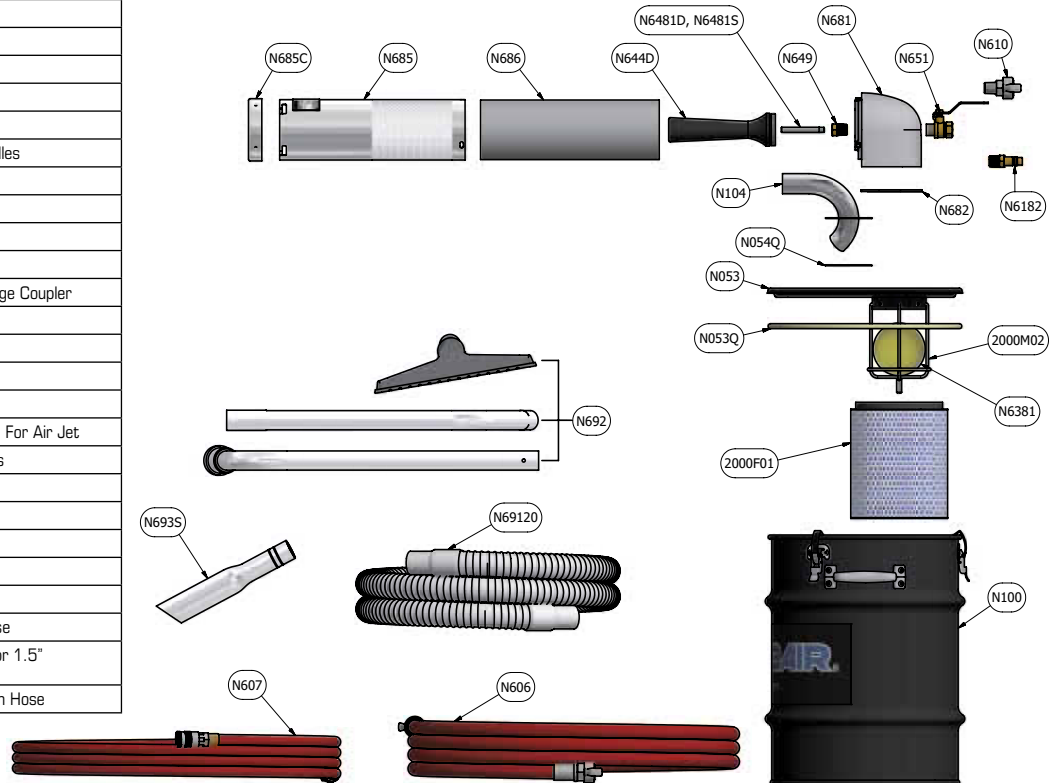

# 10 GALLON VACUUM KIT (N101MC MODEL)

Part Number	Description
2000F01	Filter
2000M02	Liquid Shut Off Cage
N053	5 and 10 Gallon Lid
N053Q	Vacuum Inlet Gasket
N054Q	5 and 10 Gallon Lid Gasket
N100	10 Gallon Canister With Lid Clamps and Handles
N104	1 1/2" Vacuum Inlet
N12510	1 1/4" X 10' Standard Duty Vacuum Hose
N6381	Liquid Shut Off Ball
N644M	M Series Venturi
N6481S	S Series Orifice
N649	1/2" X 1/8" NPT Brass HEX Reducing Bushing For Air Jet
N681	Venturi Box
N682	Venturi Box Gasket
N685C	Exhaust Housing End Cap
N708B	1/2" Male NPT X 3/8" FNPT Threaded Bushing
N842	20" Plastic Extension For 1 1/4" Vacuum Hose
N843	3" Plastic Round Brush Tool For 1 1/4" Vac Hose
N845	5" Wide Plastic Utility Tool With Brush For 1 1/4" Vacuum Hose
N846	3/8" ID Air Line Coupling
N848	3/8" ID X 12" Air Supply Hose
N849	9" Plastic Crevice Tool For 1 1/4" Vacuum Hose
N851	3/8" Male NPT Shut-Off Valve
N885	Exhaust Housing - Short
N886	Exhaust Silencer Foam Insert

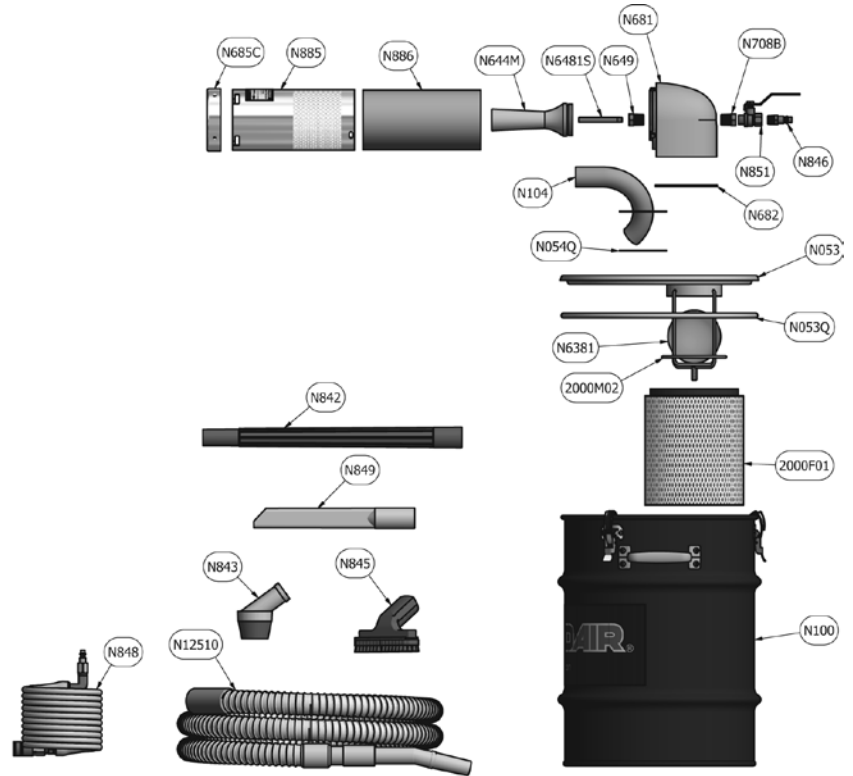

# 5 GALLON VACUUM KIT

Part Number	Description
2000F01	Filter
2000M02	Liquid Shut Off Cage
N050	5 Gallon Canister With Lid Clamps
N053	5 and 10 Gallon Lid
N053Q	Vacuum Inlet Gasket
N054Q	5 and 10 Gallon Lid Gasket
N104	1 1/2" Vacuum Inlet
N12510	1 1/4" X 10' Standard Duty Vacuum Hose
N6381	Liquid Shut Off Ball
N644M	M Series Venturi
N6481S	S Series Orifice
N649	1/2" X 1/8" NPT Brass HEX Reducing Bushing For Air Jet
N681	Venturi Box
N682	Venturi Box Gasket
N685C	Exhaust Housing End Cap
N708B	1/2" Male NPT X 3/8" FNPT Threaded Bushing
N831	Handle With Grip For 4 Gallon Vacuum Units
N842	20" Plastic Extension For 1 1/4" Vacuum Hose
N843	3" Plastic Round Brush Tool For 1 1/4" Vac Hose
N845	5" Wide Plastic Utility Tool With Brush For 1 1/4" Vacuum Hose
N846	3/8" ID Air Line Coupling
N848	3/8" ID X 12" Air Supply Hose
N849	9" Plastic Crevice Tool For 1 1/4" Vacuum Hose
N851	3/8" Male NPT Shut-Off Valve
N885	Exhaust Housing - Short
N886	Exhaust Silencer Foam Insert

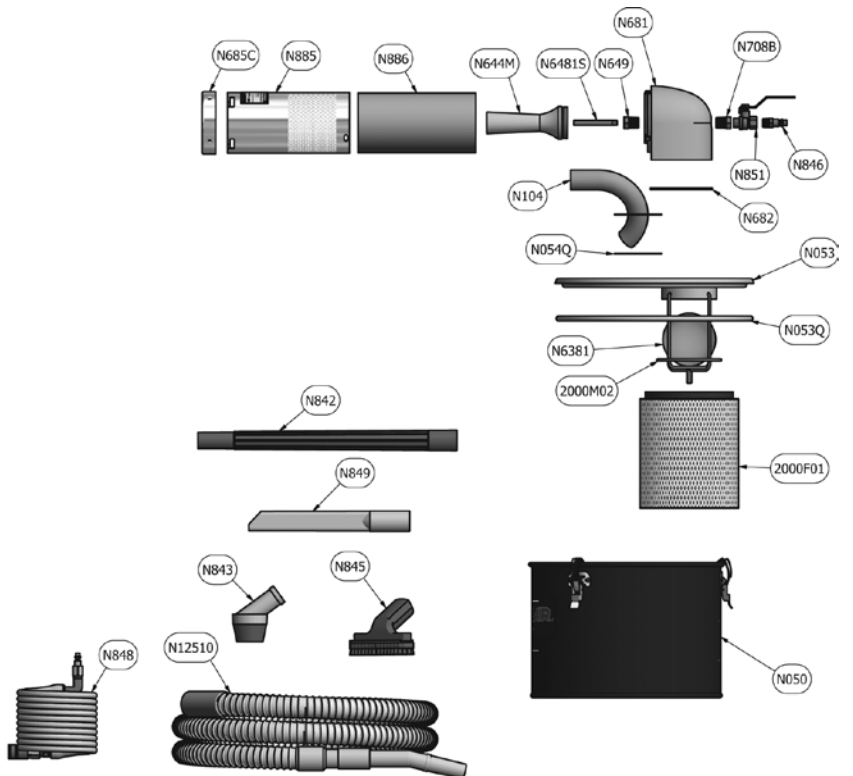



## SINGLE VENTURI VACUUM GENERATING HEAD

Part Number	Description
N610	1/2" NPT Chicago Coupler
N6182	1/2" NPT X 1/2" Male US Industrial Interchange Coupler
N6273	Venturi Box Mounting Hardware (Set)
N644	B Series Venturi
N644D	D Series Venturi
N644M	M Series Venturi
N6481B	B Series Orifice
N6481D	D Series Orifice
N6481S	S Series Orifice
N649	1/2" X 1/8" NPT Brass HEX Reducing Bushing For Air Jet
N651	1/2" NPT Ball Valve, Brass For Compressed Air Shut-Off
N681	Venturi Box
N682	Venturi Box Gasket
N685	Exhaust Housing-Long
N685C	Exhaust Housing End Cap
N686	Exhaust Silencer Foam Insert
N885	Exhaust Housing - Short
N886	Exhaust Silencer Foam Insert

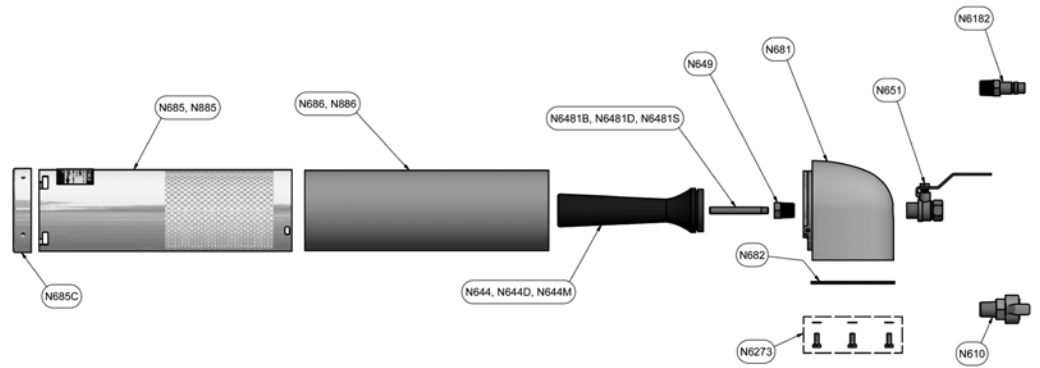

## DUAL VENTURI VACUUM GENERATING HEAD

Part Number	Description
N644	B Series Venturi
N646	Brass Shut-Off Valve For Dual Venturi Models
N647	3/4" NPT Chicago Coupler
N6481B	B Series Orifice
N649	1/2" X 1/8" NPT Brass HEX Reducing Bushing For Air Jet
34H07	Nipple, 3/4" NPT Fully Threaded, Schedule 40, Steel
N682X02	Dual Head Venturi Box
N682	Venturi Box Gasket
N685	Exhaust Housing-Long
N685C	Exhaust Housing End Cap
N686	Exhaust Silencer Foam Insert
N6271	Dual Venturi Box Mounting Lock Washers
N627	Dual Venturi Box Mounting Bolts

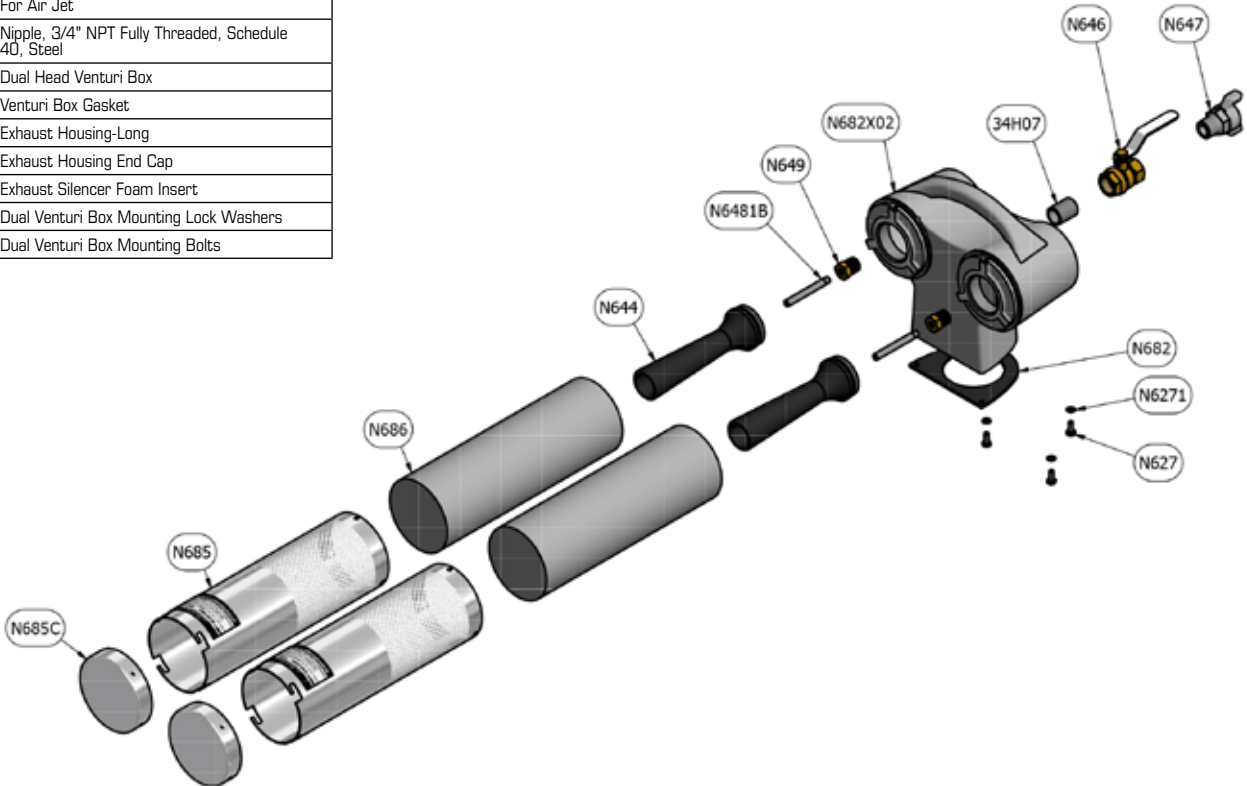

## SINGLE VENTURI VACUUM GENERATING HEAD WITH PULSEAIR™ UNIT

Part Number	Description
N635B	Pre-Filter Bag
N635H1	HEPA Cartridge Filter
N640MNEDPA, N641MNEDPA	Lid for PulseAir 30/55 Gallon Drum
N644	B Series Venturi
N644D	D Series Venturi
N610	1/2 NPT Chicago Coupler
N6481B	B Series Orifice
N6481D	D Series Orifice
N651	Brass Shut-Off Valve for Single Venturi Models
N660	Retaining Springs
N681	Venturi Box
N682	Venturi Box Gasket
N685	Exhaust Housing - Long
N685C	Exhaust Housing End Cap
N686	Exhaust Silencer Foam Insert
N715	1 1/2" Vacuum Hose Adapter - 20 Gallon
N720	2" Vacuum Hose Adapter - 30/55 Gallon
N730X03M	PulseAir Manifold
N7315	Elbow
N7316	Tubing
N7322	Check Valve w/Exhaust Cover
N7363	3/4" x 1/4" NPT Reducer
N737	Filter Bag Clamp

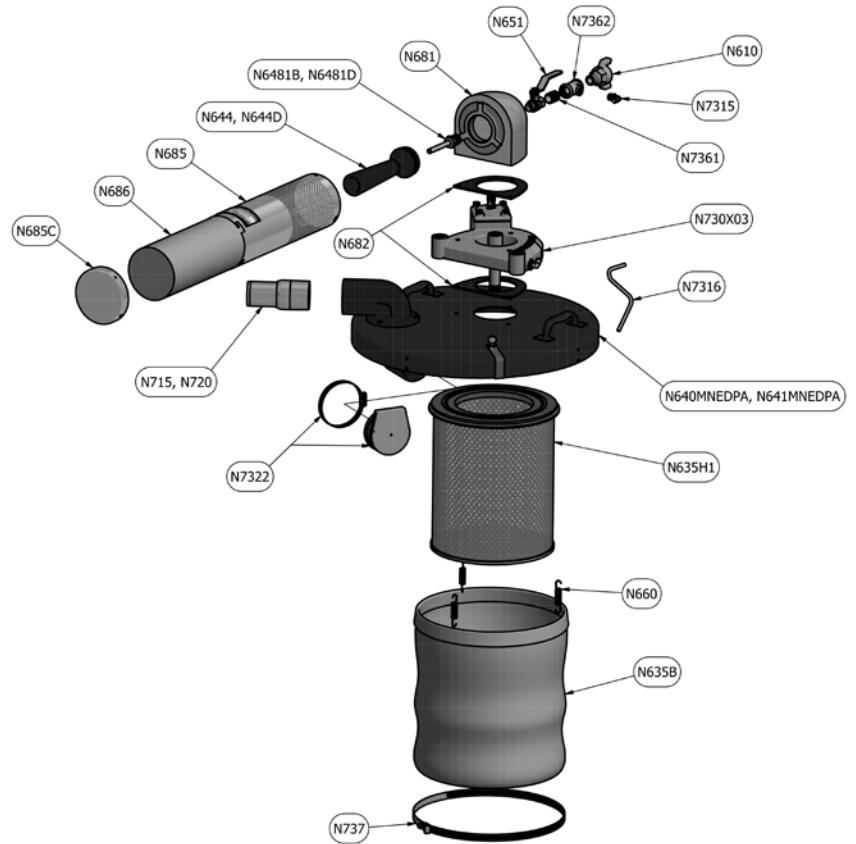

## DUAL VENTURI VACUUM GENERATING HEAD WITH PULSEAIR™ UNIT

Part Number	Description
34H07	Nipple, 3/4" NPT Fully Threaded, Schedule 40, Steel
N635B	Pre-Filter Bag
N635H1	HEPA Cartridge Filter
N640MNEDPA, N641MNEDPA	Lid for PulseAir 30/55 Gallon Drum
N644	B Series Venturi
N647	3/4" NPT Chicago Coupler
N646	Brass Shut-Off Valve For Dual Venturi Models
N648	B Orifice
N660	Retaining Springs
N682	Venturi Box Gasket
N682X02	Dual Head Venturi Box
N685	Exhaust Housing
N685C	Exhaust Housing End Cap
N686	Exhaust Silencer Foam Insert
N720	2" Vacuum Hose Adapter
N730X03M	PulseAir Manifold
N7315	Elbow
N7316	Tubing
N7322	Check Valve w/Exhaust Cover
N7363	3/4" x 1/4" NPT Reducer
N737	Filter Bag Clamp

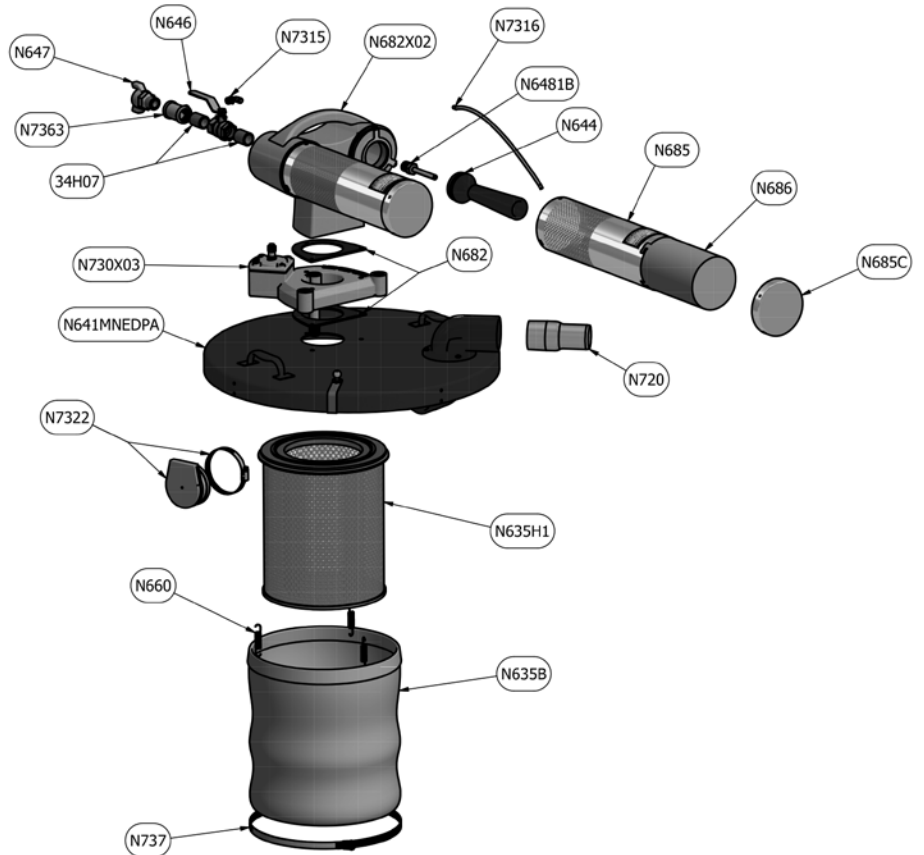

---

# **WARNING**

## **FIRE/EXPLOSION DANGER**

**Guardair vacuums, like all other electric and pneumatic vacuums, generate static electric charges. Factory installed kits to control static electricity, the use of static conductive hoses and grounding straps, and Guardair Static Conductive Pneumatic Vacuums are intended to control and eliminate static electric shocks only to the operators of the vacuums. Guardair vacuums are NOT APPROVED OR SAFE to use in any hazardous (classified) location, such as locations determined under NFPA 70 (National Electrical Code) to be Class I (flammable liquids, gases and vapors – includes all Class I Divisions and IEC Zones), Class II (combustible dust – includes all Class II Divisions and IEC Zones) and Class III (ignitable fibers and flyings – includes all Class III Divisions and IEC Zones).**

---

### **NOTES:**

---

---

---

---

---

---

---

---

---

---

---

---

---

---

---

---

---

---

---

---

---

---

---

---

NG00A01-4  
11.28.23



**GUARDAIR®**

47 Veterans Drive • Chicopee, MA 01022-1062  
Toll-Free: 800-482-7324 | Local: 413-594-4400 | Fax: 413-594-4884  
Email: [info@guardair.com](mailto:info@guardair.com) • [guardair.com](http://guardair.com)

