

# Power Mixer

Model No: P8014KP

This product has a 2 Year Parts and Labour warranty. To avail of this warranty please register your purchase by visiting our website.

[www.powerpointappliances.ie](http://www.powerpointappliances.ie)

## **INSTRUCTIONS:**

Please read and keep safe for future use. The serial no. is located at the base of the appliance.

# Product Overview

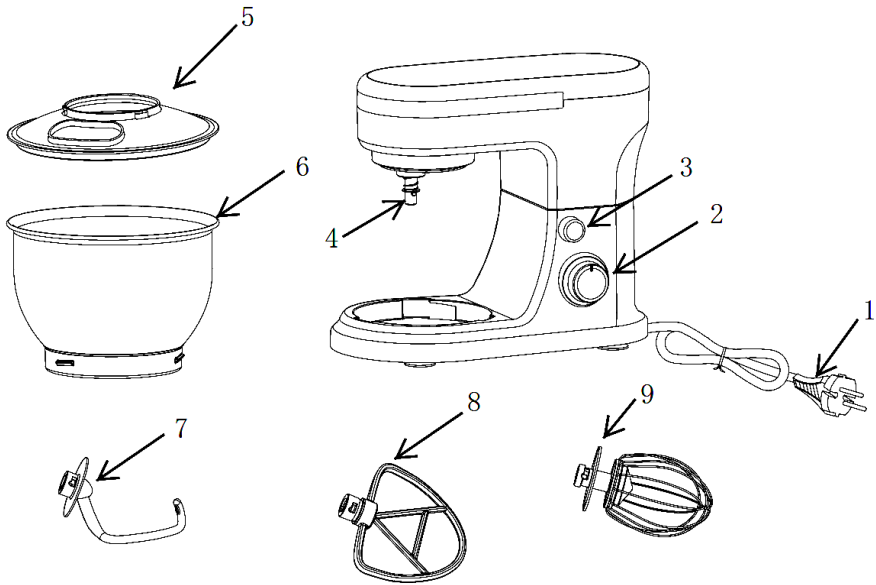

## Main Components and Standard Accessories:

1	Power Cord	6	Mixing bowl
2	Speed knob	7	Dough hook
3	Rise button	8	"A" Beater
4	Output shaft	9	Whisk
5	Bowl cover		

## Assembly

**WARNING:** ALWAYS make sure the appliance is turned off and unplugged before assembly and disassembly.

1. Wash all parts before first use, see cleaning instructions
2. Raise the mixer head until it locks into place using the head-lift release button (2).
3. Attach the lid (9) to the mixer and turn it until it locks in place.
4. Attach the beater(7), whisk (8) or dough hook (6) into the output shaft (1) and turn the shaft ring until it locks in place.
5. Place the bowl (5) on the base and turn it until it locks in place.
6. To lower the mixer head, push the head-lift release button (2) to release the head and lower it until it locks in place.

## Using the Mixer

**WARNING:** Never run the mixer for longer than 10 minutes as it will overheat.

1. Make sure the speed control knob is set to “0”.
2. Plug in the appliance
3. The blue power indicator light will illuminate.
4. Fill the bowl with ingredients. Do not overfill the bowl. The maximum quantity of ingredients is 1.2 kg.
5. Select the desired speed as suggested below. These guides are recommendations. Please adjust the mixer speed as necessary. If you feel the machine labouring, increase the speed.
6. Mix until desired consistency is achieved.

Speed	Use	Type of mixture
1 to 4	Dough hook	Heavy mixtures (e.g. bread or short pastry)
3 to 4	Beater	Medium-heavy mixtures (e.g. crepes or sponge mixture)
5 to 6	Whisk	Light mixtures (e.g. cream, egg white, blancmange)
Pulse	Whisk	Interval (e.g. for mixing sponge, egg white)

**Short operation time:** With heavy mixtures, do not operate the appliance for more than 6 minutes and allow to cool for a further 10 minutes

## *The Mixer Tools and their Uses*

### **The Whisking Attachment (8)**

Use the whisk attachment for whisking eggs, cream, instant puddings, all in one cake mixes, creaming margarine with sugar (use a block margarine at room temperature) and mixing eggs into sponge and fruit cakes. Don't use the whisk for heavy mixtures as it could be damaged.

### **Dough Hook (6)**

Use the dough hook for yeast mixtures.

## Beater (7)

Use beater for mixing flour or fruit into cake mixes and making short crust pastry.

To Remove Tools switch the mixer off and unplug the unit. Push the release and raise the mixer head. Push again to lower the head when the tool has been removed.

## *Cleaning*

1. Before cleaning and maintenance, switch the appliance off and unplug it.
2. Remove all attachments. All attachments can be washed in warm soapy water. Ensure that they are thoroughly dried.
3. Wipe the outside of the mixer with a damp cloth, then leave to air dry. Never use abrasives or immerse in water.
4. Wash the bowl in hot soapy water. After cleaning re-fit the bowl. This will keep the mixer head mechanism covered.

## *Health & Safety*

### *Important Safety Instructions*

The use of any electrical appliance requires the following of basic common sense safety rules. Primarily there is danger of injury or death and secondly the danger of damage to the appliance.

**WARNING: Danger to the person!**

### *Location*

- Do not use outdoors

### *Mains Lead*

- The mains lead should reach without straining the connections
- Do not let the mains lead hang over the edge of a worktop where a child could reach it
- Do not let the lead run across an open space e.g. between a low socket and table
- Do not let the lead run across a cooker or toaster or other hot area which might damage the cable

### *Personal Safety*

**WARNING: To protect against fire, electric shock and personal injury do not immerse cord, plug or Mixer in water or other liquid**

- Unplug from outlet when not in use, before cleaning, removing or attaching parts. To disconnect, turn off, grasp plug and unplug from wall. Never pull on the cord
- Avoid contact with moving parts. Keep hands, hair, clothing as well as spatulas and other utensils away from the beater, whisk or dough hook during operation to prevent injury or damage to the Mixer
- Don't let rotating blades touch the mains cable
- Remove the attachments from the mixer before washing
- Keep hands and other utensils out of the bowl while blending food to reduce the risk of severe injury to persons or damage to the unit
- Make sure the mixer is switched off before connecting to or disconnecting from the mains supply
- Do not use during cooking processes or with boiling liquids

- Do not operate in the presence of explosive and/or inflammable fumes

### *Children*

- Do not allow children to use this appliance. Children are vulnerable in the kitchen particularly when unsupervised and if appliances are being used or cooking is being carried out

### *Other safety considerations*

- Do not operate any appliance with a damaged cord or plug or after the appliance malfunctions or has been damaged in any manner
- Do not overfill the Mixer. This could cause damage to the motor. The 3 amp fuse will blow if the mixer is overloaded. Replace the fuse and do not exceed the recommended volumes
- Do not use accessories that are not recommended by the manufacturer as there is the danger of fire, electric shock or personal injury
- Do not place on or near a hot gas or electric burner or in a heated oven
- Unplug from outlet when not in use
- Do not use this appliance for other any use other than it is intended

### *Electrical Requirements*

Check that the voltage on the rating plate of your appliance corresponds with your house electricity supply which must be A.C. (Alternating Current).

If the socket outlets in your home are not suitable for the plug supplied with this appliance, the plug should be removed and the appropriate one fitted.

**WARNING: The plug removed from the mains lead, if severed, must be destroyed as a plug with bared flexible cord is hazardous if engaged into a live socket outlet.** Should the fuse in the 13 amp plug require changing, a 3 amp BS1362 fuse must be fitted.

**WARNING: This appliance must be earthed**

## *Warranty Information.*

### *Registering Your Two Year Guarantee*

Your standard one year guarantee is extended for an additional 12 months when you register the product within 28 days of purchase with the supplier Shomar Ltd. If you do not register the product with Shomar Ltd within 28 days, your product is guaranteed for 1 year. To validate your 2 year guarantee register with us by logging onto our website [www.powerpointappliance.ie](http://www.powerpointappliance.ie) and go to the warranty registration area.

Please note that the 2 year guarantee is only available in Ireland and the UK.

### *One Year Guarantee*

It is important to retain the retailer's receipt as proof of purchase. Staple your receipt to this back cover for future reference.

Please quote the following information if the product develops a fault. These numbers can be found on the base of the product.

Model no.

Serial no.

All Powewrpoint products are individually tested before leaving the factory. In the unlikely event of any appliance proving to be faulty within 28 days of purchase, it should be returned to the place of purchase for it to be replaced.

If the fault develops after 28 days and within 12 months of original purchase, you should contact the Helpline number quoting Model number and Serial number on the product or write to Shomar Ltd at the address shown.

You may be asked to return a copy of proof of purchase.



Subject to the exclusions set out below (see Exclusions), the faulty appliance will then be repaired or replaced and dispatched usually within 7 working days of receipt.

If, for any reason, this item is replaced during the 1 year guarantee period, the guarantee on the new item will be calculated from original purchase date. Therefore it is vital to retain your original till receipt or invoice to indicate the date of initial purchase.

To qualify for the 1 year guarantee, the appliance must have been used according to the instructions supplied. For example, crumb trays should have been emptied regularly.

### *Exclusions*

Shomar Ltd shall not be liable to replace or repair the goods under the terms of the guarantee where:

1. The fault has been caused or is attributable to accidental use, misuse, negligent use or used contrary to the manufacturer's recommendations or where the fault has been caused by power surges or damage caused in transit.
2. The appliance has been used on a voltage supply other than that stamped on the products.
3. Repairs have been attempted by persons other than our service staff.
4. The appliance has been used for hire purposes or non domestic use.
5. The appliance is second hand.
6. Shomar Ltd are not liable to carry out any type of servicing work, under the guarantee.

This guarantee does not confer any rights other than those expressly set out above and does not cover any claims for consequential loss or damage. This

guarantee is offered as an additional benefit and does not affect your statutory rights as a consumer.

This guarantee is valid in Ireland and the UK only.

Powerpoint products are intended for household use only. See usage limitations within the location safety instructions.

Shomar Ltd has a policy of continuous improvement in product quality and design. The company, therefore reserves the right to change the specification of it's models at any time.

## *Contact Details*

The After Sales Division for Powerpoint Appliances is located at the offices of the Brand owner and Distributor –

Shomar Ltd, Unit 9 Western Industrial Estate, Dublin 12, Republic Of Ireland.

Helplines (office hours) & Spare Parts contact number is 01-450 5327 or email [service@shomar.ie](mailto:service@shomar.ie)