

Built-in oven

Instructions for use installation

Family use built-in oven

Model: **P25CKYLSS**



Thank you so much for purchasing this product.

This product is for domestic use only.

Please read this instruction manual carefully before using the product to ensure the correct and safe use of this product.

Pay special attention to Safety Precautions. (Page 3-6).

Please safekeeping the Warranty Certificate and the User's manual .

Contents

Safety precautions.....	3-6	Timer setting.....	15
use precautions.....	7-9	Clock setting.....	15
Initial use precautions.....	9	Automatic programmer setting.....	16
Appliance parts and operation.....	9	Cleaning and maintenance.....	17
Oven component.....	9	Oven interior /oven door.....	17
Accessories.....	10	Remove the oven door.....	18
Control panel.....	11	Remove the slide-in racks.....	18
Function settings.....	12	Oven light replacement.....	19
Cooking knacks.....	13	Sensor probe replacement.....	19
Usage method.....	14	Specifications.....	10
Cooking suggestion and instructions.....	14	Installation Instructions.....	21-24
Energy saving tips.....	14	Warranty & after sales service.....	25

Safety Precautions

Be sure to observe

To prevent the bodily injury and property damage, please be sure to observe the following safety precautions.

- The following icons show the extent of damage caused by incorrect operations.



Warning: Indicates a potential hazard that, if unavoidable, may result in death or serious injury.



Note: Indicates a potential hazard that, if unavoidable, may result in death or moderate injury.

The classification and interpretation of icons are as follows.



This icon indicate that cannot be in progress, i.e. "Prohibited".



This icon indicate that it must be executed, i.e. .

Contents



 **Do not** use the appliance if the power cord or the power plug has been damaged, or the interface between the power sockets and the power plug is loose.

(To avoid electric shock or fire due to short circuit.)

→ If the soft wire of the power supply is damaged, in order to avoid danger, it must be replaced by professionals of the manufacturer, its maintenance department or similar departments.

Do not damage power cord or power plug.

- The following operations are absolutely prohibited:

Do not allow the cable to come in contact with high temperatures or move the product by pulling on the cable.

(To avoid electric shock due to breakage of power cord and power plug, or fire due to short circuit.)

Do not insert anything into the opening of the oven.

- Especially the metal objects, such as lead wire or electric wire.

(To avoid electric shock or injury caused by abnormal movements.)

Do not install the decorative door panels in front of the oven.

(To avoid the door panels become deformed caused by overheating.)

Keep away from the appliance while in use or just after use. Pay special attention to children. (To avoid scalds)

Do not place objects other than heat-resistant pottery in this product.

(To avoid fire caused by high temperature melting.)

Prohibition example:

- Flammable objects such as plastic containers.

- Articles made of aluminium foil, etc.

Do not use this appliance to heat the room.

(To avoid causing fire and shortening product life.)

Do not use this appliance to heat unopened canned products.

(To avoid fire, scald or injury cause by explosion due to pressure accumulation.)

 **Do not** alter, disassemble or repair the product by yourself. (To avoid causing fire, electric shock or injury.)

For repairs, please contact (Company name) Certification Maintenance Store for consultation.

Do not clean the oven door glass with a rough scrubber or sharp scraper.
(In order to avoid scratches on the surface of glass, resulting in glass failure.)

Be sure to use AC power sockets with specifications of AC220V-240V/16A separately.
(In order to avoid fire caused by heating when used with other electrical appliances.)
Be sure to use the wiring boards with specifications of at least 16A.

Be sure to plug the power plug fully into the socket.
(In order to avoid causing smoke, fire or electric shock.)

This product should be properly connected to the grounding system in accordance with national and local safety regulations.
(To avoid the risk of electric shock in case of malfunction or leakage.)

Users must test this basic security requirement. If there is any doubt, it should be tested by a qualified electrician.

Make sure that the product is installed correctly and all electrical components are installed correctly before use.
(To avoid causing fire or injury.)

This product is not suitable for following persons (including children) : persons with reduced physical, sensory or mental capabilities or lack of experience and knowledge if they have been given supervision or instruction concerning use of the appliance in a safe way and understand the hazards involved. Children shall not play with the appliance. Cleaning and user maintenance shall not be made by children without supervision.
(To avoid burns, injuries or electric shocks.)

Dispose of all packaging materials to avoid danger to children.

Remove the plug if any fault occurs.

When installing, maintaining and repairing this appliance, make sure to disconnect the power supply.
(To avoid electric shock or injury.)

Make sure to turn off the power supply before changing the light .(To avoid electric shock.) Before the first use, please burn it empty to remove the odor. (See the appendix [Initial use precautions])
(Not to affect the normal use of the appliance.)

Remove packing parts and cushioning materials before use.(To avoid fire causing by temperature raising).

Safety Precautions

 **NOTE!**

Be sure to observe

 **Do not** put inflammable materials in the oven.
(So as not to cause a fire when accidentally turning on the oven)

Do not sit or lean on the open door.

Do not use abrasive, corrosive cleaners or sharp metal scrapers to clean glass doors of oven.
(To avoid scratching the surface, or even causing glass to break.)

Do not use steam cleaner to clean this product.
(To avoid short circuit or product failure.)

 **Do not** touch the bottom of the product after the power is turned on.
(To avoid scalds.)

During cooking the food with fat or oil release, be sure to be watched by someone.
(To avoid causing fire.)

When pulling out the power plug, make sure to hold the plug .
(To avoid electric shock or fire due to short circuit.)

Do not replace your hands on either side of the door when it closes.
(To avoid injuries caused by clamping fingers when closing the door.)

Use Precautions

Focus on product

Before the first use, please remove all the protective film on the product (except rating label).

(To prevent the protective film from melting due to high temperature and scalding after touching.)

Before first use, please remove packaging material from the oven.

(Grill, cardboard on both sides of the baking tray, cushioning foam in front and rear of the grill and strapping tapes on the slide rail).

During operation, the oven become very hot, and heat-resistant gloves should be worn when operating.

(To avoid scalds.)

During operation, the oven door must be closed and confirm there is no object stuck on the oven door.

(To avoid affecting the cooking effect.)

Do not leave sugary food residues (such as jam) in the oven.

(To avoid damaging the enamel inside the oven.)

Do not use plastic products in the oven.

(To avoid the melting of plastic will damage the oven cause by high temperature.)

During using the oven, do not cover the bottom of the oven with aluminum foil, tin foil, or place pans and baking tray at the bottom of the oven.(To avoid damaging the enamel inside the oven.)

Do not add water to the drip tray if the oven is still hot.

(In order to avoid steam burn out or damage the enamel surface.)

Do not use spray cleaner.

(Avoid causing insulation aging ,thereby damaging the oven.)

Use Precautions

Slide-in racks Placement Warning

In order to ensure the safe use of the grate or tray, it is necessary to insert in the right direction and place the slide-in racks correctly.

In addition, you can also refer to the level number displayed in the front of the oven when you open it. (There are five levels altogether.)

This ensures that food does not slip out of the back during careful removal from the grate or tray.

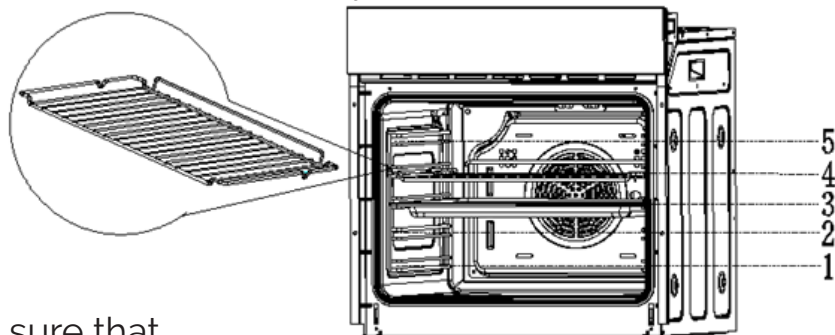

Before closing the oven door, make sure that the grate (baking tray) is in place and that the grate (baking tray) does not touch the glass inside the oven door.

Removal of Packaging Components and Cushioning Materials

Remove packaging materials before use

Before the initial use, please remove the packing material according to the drawing first, the other operations can be carried out.

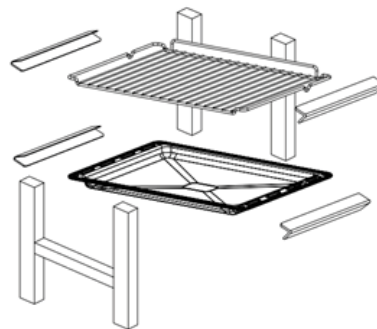

Please pay attention to remove the packing materials in the oven

Initial Use Precautions

Note: When using oven for the first time, there may be a small amount of smoking and odor, which is a normal phenomenon.

Please adjust the temperature of the empty oven to 250 , and bake it with stereoscopic function for 30 minutes before using it.

Initial Use Operation

- 1 Remove all cushioning material
- 2 Operate the empty oven for about 30 minutes with top and bottom heat mode and maximum temperature.
- 3 The resulting typical smell is unavoidable. Please ventilate the room.

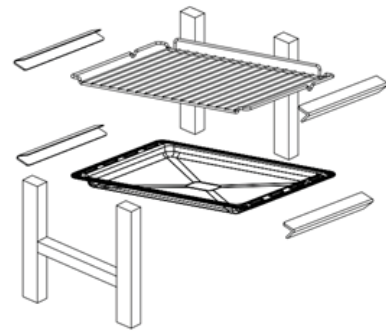

Appliance parts and operation

Oven Component

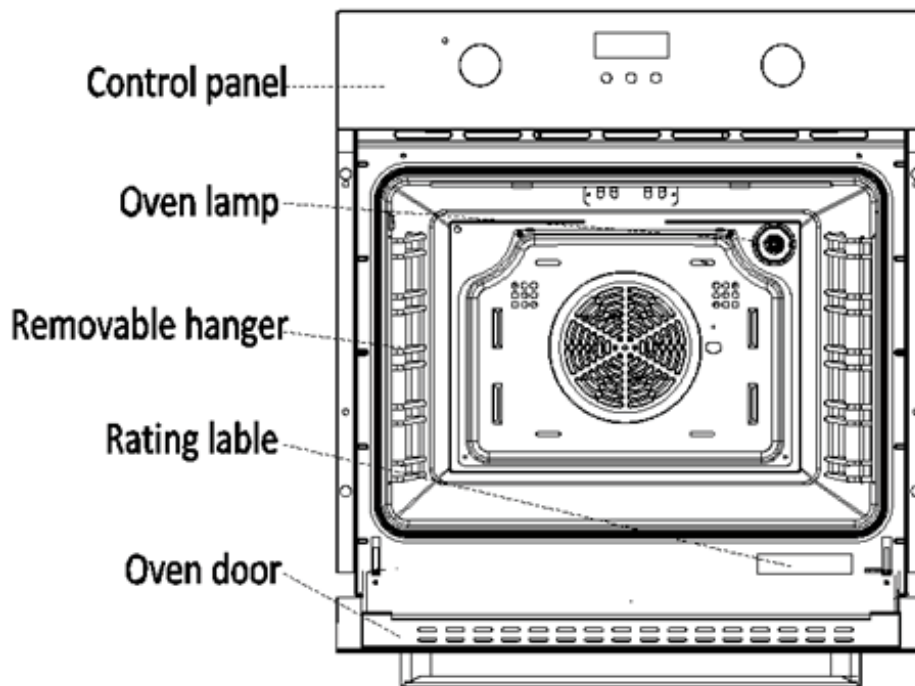

Accessories

Before first use, please clean all accessories and use soft cloth and neutral detergent to clean the oven.

Only original accessories can be used.



Grate

Used for baking and barbecuing

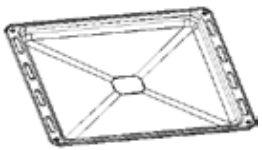

Enameled baking tray

Used for cooking large amounts of food, such as damp cakes, pastries, frozen foods, or for collecting fat/spills and gravy

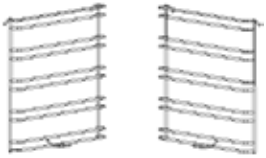

Slide-in racks

When cleaning the oven wall, the racks on both sides can be removed



Screw assembly

Screws (2) for fixing product

Appliance parts and operation

Control Panel

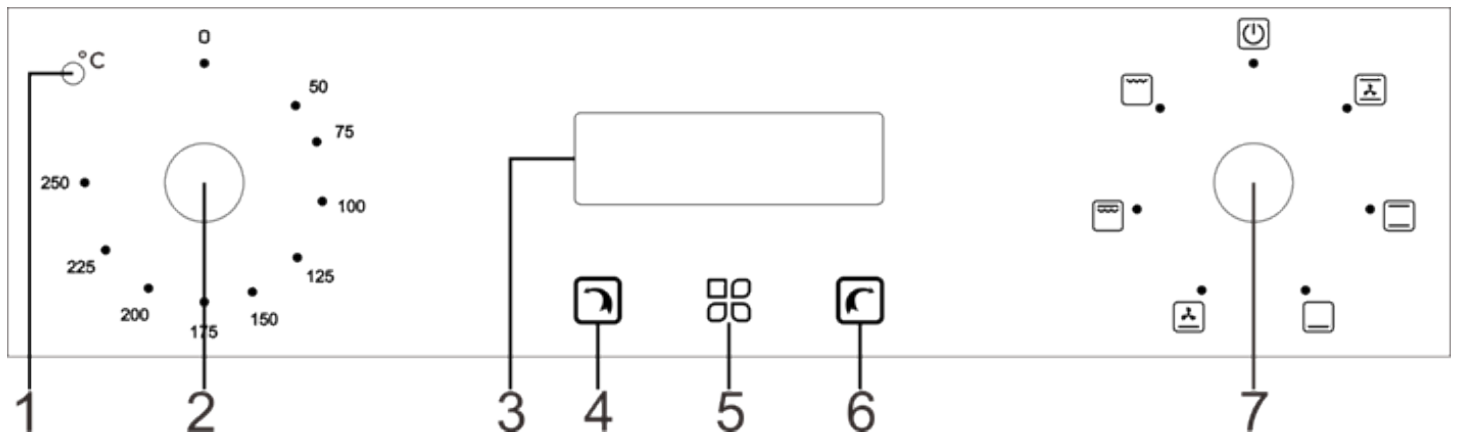

1. Indicator light

(indicates the heating process, i.e. the operation of one or more heating elements)

2. Temperature setting knob

Rotate the knob to select the desired temperature.

3. Main display screen

4. Decrease button

5. Timing/Clock button

6. Increase button

7. Function setting knob

Rotate the knob to select the desired function.

Appliance parts and operation

Function Settings

Turn the knob to the relevant icon and select the cooking functions required.

ICONS

FUNCTION DESCRIPTION



Conventional+fan

The combination of fan and two heating elements can provide more uniform thermal penetration performance and save 30-40% energy. The outside of the food is slightly brown but the inside is still wet.

Note: * This function is suitable for high temperature roasting or roasting large pieces of meat.



Top and bottom heat

The top and bottom work together, and can be used for routine cooking operations.



Bottom heat

The concealed element at the bottom of the oven provides more concentrated heat without browning. This is suitable for slow cooking dishes, such as crisp casseroles, stews, pastries and pizza.



Bottom heat+fan

The rear fan and the lower heating element can work at the same time. The temperature can be set in the range of 50°C to 250°C.



Double grilling









The upper inner ring heating element and the outer ring heating element can work at the same time. The temperature can be set in the range of 50°C to 250°C.



Radiant grilling

The upper inner ring heating element working. The temperature can be set in the range of 50°C to 250°C.

Cooking Knack

FOOD	WEIGHT (KG)	LEVEL	FUNCTION SETTING	TEMPERATURE (IN °C)	FIRST FACE (SECONDS)	SECOND FACE (SECONDS)	ACCESSORY
BISCUIT	0.5	3		200	10-15	-	BAKING TRAY
SANDWICH	0.2	3		180	15-20	-	GRATE
SWISS ROLL	0.2	3		180	10-18	-	BAKING TRAY
SMALL CAKE	0.3-0.4	3		185	20-25	-	BAKING TRAY
SPONGE CAKE	0.5	3		175	30-35	-	GRATE
PIZZA	0.35	3		200	10	-	BAKING TRAY
APPLE PIE	1.2	3		185	50-60	-	GRATE
TOAST	9pcs	5		240	1-2	-	GRATE
HAMBURGER	1	5		240	10-20	5-10	BAKING TRAY

Usage Method

Cooking Suggestions and Instructions

Normal Suggestions

We suggest to preheat the oven before the food is put into the oven.

Normally, it is impossible to shorten the cooking time by increasing the temperature (food may be well cooked outside, but not yet inside).

If cooking is done on a multi-layer grill, we suggest using a Conventional + fan function so that uniform cooking can be achieved at all heights.

In order to achieve the best cooking effect, we suggest that the suitable ware should be placed in the center of the grill or tray.

In order to prevent the formation of excessive condensation beads on the inner glass, after cooking, hot food should not be placed in the oven for a long time.

Suggestions on meat cooking

The cooking time of food, especially meat, varies with the thickness and quality of the meat and the taste of the user.

We suggest using meat thermometers when cooking meat. (The thermometer is not supplied with the oven.)

If necessary, food can be wrapped in aluminum foil for cooking to make the food more tender.

Suggestions on cake and biscuits cooking

Dark metal molds can absorb heat better when baking cakes.

Temperature and cooking time depend on the quality and consistency of the mixture.

To check the cake is ripe or not, at the end of cooking time, insert the metal pole to the top of the cake and cooked insert a knife if the blade comes out dry the cake is cooked.

If the cake collapses when it comes out of the oven, the next you can extend the time appropriately, if necessary, can also be reduced by about 10°C for baking.

Energy saving tips





In order to save energy in the use of ovens, the following instructions can be followed:

1. The door must be completely closed for all cooking operations.
2. Please don't open the oven door frequently while cooking, because it will let the heat out of the oven.
3. Turn off the power completely when not in use.
4. Always keep the Oven interior clean.

Timer Setting

Clock Setting











Used for display the current time on the screen. Clock must be set before use.

1. When the power is turned on, the display screen shows "12.00" and the clock icon  flashes. At this time, the oven is not working.
2. Press  or  button to set the current time. After 5 seconds, the default setting is finished and the clock icon  is off.



Alarm Setting







For setting alarm functions on any function, the setting time range is:

1 minute < T < 23 hour and 59 minutes

1. Press the button  until you see  flashes on the screen, then set the alarm function.
2. Press  or  set the required alarm time (alarm time = current time + set time).
3. After 5 seconds,  lighting, the setup is finished.
4. When the working time reaches the set time, the alarm function will be activated, and the  will flash. At this time, press the ,  or  button, the alarming sound will be stopped and the  goes off. If you do not press any button, the alarming sound will be stopped after 2 minutes.









Cooking Time Setting

Used for cooking for a selected period of time, when the setting time comes, the oven shuts off automatically, cooking time adjustment range: 0 < T < 10 hours; Press the button  until you see  flashes on the screen, then set the cooking time.

1. Press the  or  to set the cooking time you want. When  is constant lighting, that means the setting is completed.
2. Adjust the oven function knob and temperature knob to your desired function and temperature.
3. When the cooking time is over (cooking time = current time + set time), the oven stops working. The bell rings and  flashes. Pressing ,  or  at this time will stop the bell rings. If you don't press any button, the bell ring will stop after 2 minutes.
4. When the oven is shut off, the display screen shows the current time.

Cooking End Time Setting













The oven will be shut off automatically when the cooking end time is set.
The adjustable range of the end time: the end time \leq current time + 10 hours, but the maximum end time is not more than 24 hours.

1. Press the the button  until you see  flashes on the screen, then set the cooking end time.
2. Press  or  button to set the end time you need. After 5 seconds, the default setting is completed, and  is constant Lighting.
3. Adjust the oven function knob and temperature knob to your desired function and temperature.
4. When the cooking time is over, the oven stops working. The bell rings and  flashes. Pressing ,  or  at this time will stop the bell ring. If you don't press any button, the bell ring will stop after 2 minutes.
5. When the oven is shut off, the screen displays the current time.

Cooking End Time Setting

Used for cooking for a selected time, and the oven will shut off at the end time you set.
After the function is set, the oven will automatically start up at the set time, and can cook during set time, it will automatically shut off at the end time.

Satisfy this relationship: End time =Current time (display screen time) + Cooking time



1. Press the button  until you see  flashes on the screen, then set the cooking time.
2. Press  or  button to set the cooking time you need,  will be constant lighting.
3. Press the button  until you see  flashes on the screen, then set the cooking end time.
4. Press  or  button to set the cooking end time you need, will be  constant lighting.
5. Adjust the oven function knob and temperature knob to your desired function and temperature.
6. Arrive at the set time, the oven will start up automatically and work according to the set procedure.
7. When the end time of program comes, the oven stops working, the bell rings, and the  and  are lighting at the same time.



8. Press the , , , it will stop the alarm clock. If you do not press any button, the alarming sound will stop after 2 minutes.

9. Turn the knob to the "0" position, the oven is turned off.

Setting the child-proof lock (key lock)

Your appliance is equipped with a child lock to prevent the appliance from being switched on accidentally or settings from being changed unintentionally, e.g. by children. When activated, the control keys are all locked.

1. To activate the key lock, press and hold the  and  keys for 3 seconds until the  icon is displayed. All the control keys are now locked.

2. To deactivate the key lock, press and hold down the  and  keys again for 3 seconds. The  icon disappears from the display and you can operate the appliance normally again.

Cleaning and Maintenance

Oven Interior/Oven Door

Oven door

Glass door should always be clean, to remove stubborn stains with kitchen absorbent paper, wet sponges and common detergents.

Do not use a steam cleaner to clean the oven.

Do not use detergents or corrosive detergents to clean glass door.

Do not use rough or friction materials or sharp metal scrapers to clean the oven glass door, as they may scratch the surface.

Oven Interior

In order to maintain the oven better, after cooking, the oven should be fully cooled before cleaning.

Take out all removable parts.

In order to facilitate cleaning, the oven door can be removed. (Removal method refers to "Remove the oven door" below.)

Steam cleaners should not be used when cleaning.

Remove the Oven Door

Removable oven door allows users to fully touch the oven interior, making maintenance more convenient and fast.

① Open the door to the maximum angle and pull the lock back at the hinge of the door(Figure 1). There are two locks on both sides of the oven door.

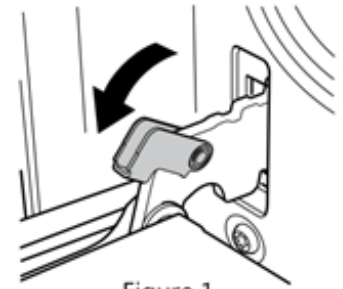

Figure 1

② Close the oven door, at about 15 degree, then lift the door, and slowly pull out from the oven.(Figure 2)

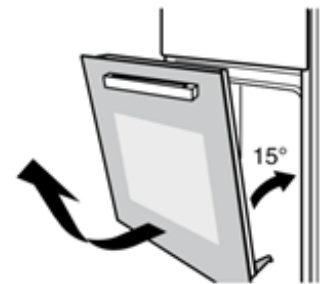

Figure 2

③ After cleaning, perform the above-mentioned operations in the opposite steps to restore the door to its original condition.

Note: After using a specific detergent, run the oven for 15-20 minutes with maximum heating settings to remove residues in the oven. In this process, touchable parts may be hotter than usual. Keep children away from the oven.

Remove the Oven Door

Remove the hanger to facilitate cleaning the side wall of the oven. Note: Operate this process must by hand slightly, or it will damage the enamel.

1. Remove all accessories such as grate and baking tray.
2. Slightly push down the hook in racks at the clamping point as shown (A).
3. Swivel the rack inwards to an angle of approx. 45 degrees(B-C).
4. Unhook it at the top and carefully pull it out (C).
5. To reinstall after cleaning, follow the steps above in reverse order.

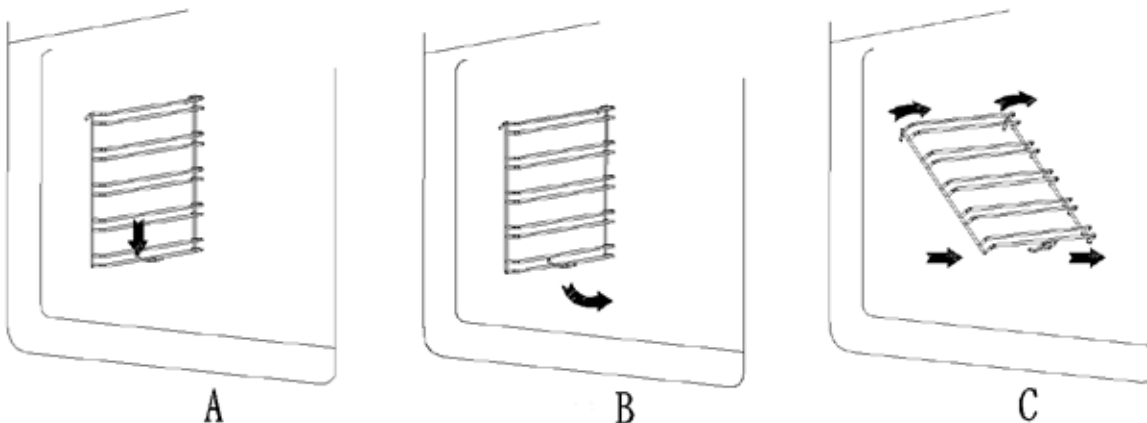

After cleaning, perform the above-mentioned operations in reverse steps to restore the components to their original positions.

Oven Light Replacement

The light used in oven is a special high temperature resistant light (AC220V/25W).

Therefore, it is necessary to purchase genuine light from authorized distributors.

The replacement steps are as follows:

- ① Disconnect the power supply of the power socket.
- ② Turn the glass cover counterclockwise.(Figure 5)
- ③ Remove the light and replace it with the same type.(Figure 6)
- ④ After replacing the light, screw the glass cover clockwise.



Figure 5

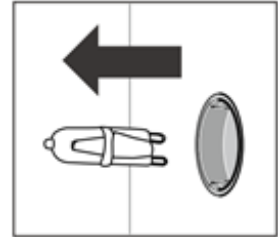

Figure 6

MODEL	P25CKYLSS
VOLTAGE	220-240V
RATED POWER	2200W
UPPER OUTER RING HEAT PIPE	1000W
UPPER INNER HEATING PIPE	1200W
LOWER HEATING TUBE	1000W
RATED FREQUENCY	50/60HZ
PRODUCT SIZE(WIDTH * DEPTH * HEIGHT)	595(WIDTH) X565(DEPTH) X595(HEIGHT)
RATED VOLUME	70L

Sensor Probe Replacement

The probe used in the oven is a mechanical physical probe. Do not replace it without authorization.

In case of abnormal temperature sensing of the sensor probe, please contact the designated repair shop immediately for replacement.

Specifications

Specifications

The standby power is about 0.5W when the power supply of the product is "off".

Installation Instructions

Important note

The kitchen cover must be suitable to ensure that the oven works properly.

The panel of kitchen equipment adjacent to the oven must be made of heat-resistant materials. Kitchen equipment made of plywood shall ensure that the glue can withstand a temperature of at least 120 degrees Celsius. When plastic or glue cannot withstand this temperature, the equipment will melt and deform.

Once the oven is placed in the kitchen equipment, the electrical components must be completely insulated. This is a statutory safety requirement.

All furnace covers must be firmly fixed in place and cannot be removed without using special tools.

Remove the back of the kitchen equipment to ensure the full circulation of air around the oven.

The oven rack must have at least 45 mm rear clearance.

Because oven handle and sheet metal parts are easy to cut, installers need to wear gloves for installation.

Electrical Connectors

WARNING!



The wiring of oven must be equipped with all-pole disconnection device according to the wiring rules.



After installing the appliance, it is necessary to have other methods to disconnect the power supply. The power supply is disconnected by a contactable plug or by a fixed wiring switch that meets the wiring requirements.

Important information

The appliance is designed to be permanently installed with a three-pin power cord and may only be connected by a licensed expert in accordance with the connection diagram.

Only a qualified electrician who takes the relevant regulations into account may replace the power cord.

Do not use multiple plugs, power strips or extensions. Overloading causes a risk of fire.

If the connection is no longer accessible following installation, an all-pin isolating switch with a contact gap of at least 3mm must be provided.

Connect the wires of the mains power cord in accordance with the following colour coding:

Green and Yellow
Blue
Brown

Earth wire  (E)
Neutral wire (N)
Live (L)



Ireland & Northern Ireland

Do not connect the appliance using a 13 A plug or protect it with a 13 A fuse. The appliance must be protected using a fuse that is rated 16 A or higher.

The appliance must be disconnected from the power supply during all installation work. When the appliance is installed, protection must be provided against accidental contact in the future.

Installation Instructions

Reasonable Fixed Oven

! NOTE!

Two persons are required to assist in the installation of the oven.

The oven base must be installed as shown below.



- 1 Pay attention to the general dimensions required for installation.

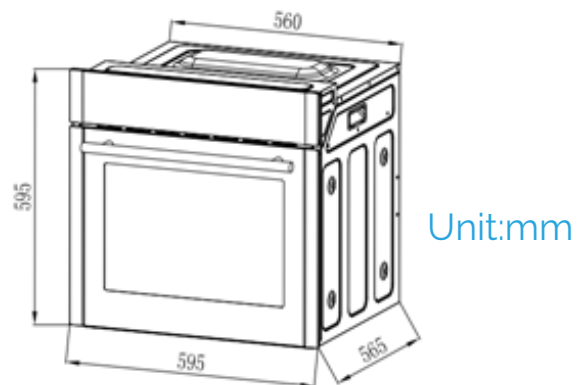

- 2 Convex
In order to have the best integration of the kitchen, please install the equipment into the standard 600 mm wide cabinet, so it can achieve a flush effect with the front of the cabinet.
The equipment can also be installed in the form of convex.

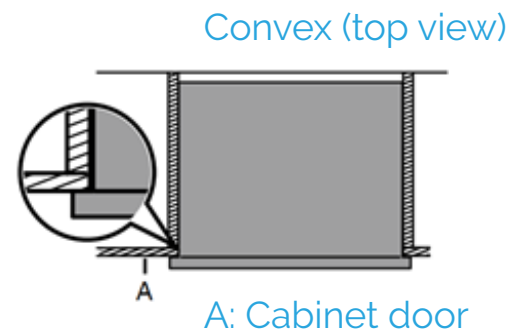

1. Before installing the equipment, please ensure that the cabinet meets the following internal empty dimensions.

To ensure air circulation, the oven must be installed in accordance with the size and distance shown in the figure below.

Note: The oven can be installed in any cabinet with heat resistance.

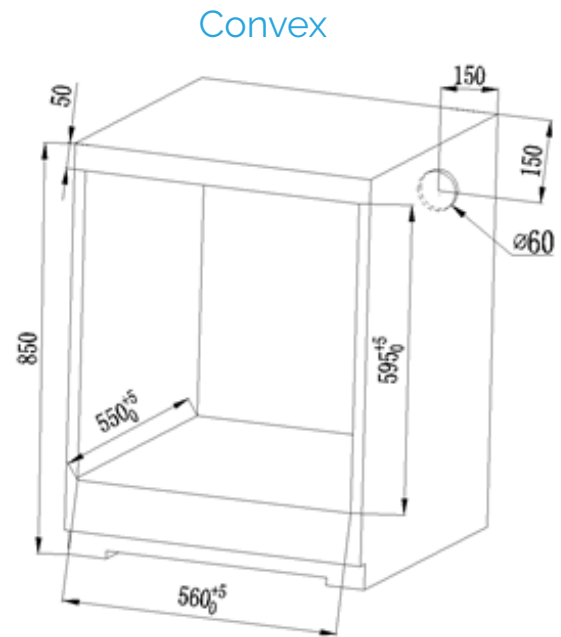

Fix Oven to Cabinet

Note: Open the oven door, check the side rack of the oven and determine the fixing hole.

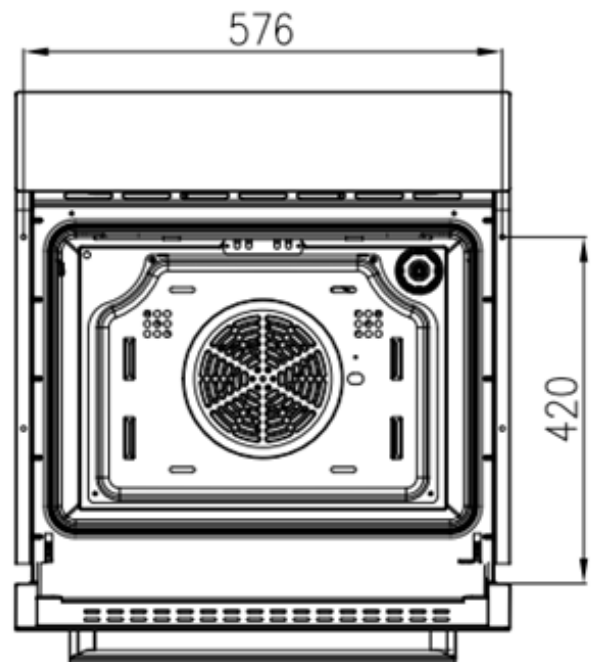

Warranty & After Sales Service

Warranty Information.

Registering Your Guarantee

Your standard one-year guarantee is extended for an additional 1 years when you register the product within 28 days of purchase with the supplier Shomar Ltd. If you do not register the product with Shomar Ltd within 28 days, your product is guaranteed for 1 year. To validate visit www.powerpointappliances.ie

Please refer to the one year guarantee for more information.

One Year Guarantee

It is important to retain the retailer's receipt as proof of purchase. Staple your receipt to this back cover for future reference.

Please quote the following information if the product develops a fault. These numbers can be found on the product.

Model no.

Serial no.

Subject to the exclusions set out below (see Exclusions), the faulty appliance will then be repaired or replaced. If for any reason, this item is replaced during the guarantee period, the guarantee on the new item will be calculated from original purchase date. Therefore it is vital to retain your original till receipt or invoice to indicate the date of initial purchase. To qualify for the 1-year guarantee, the appliance must have been used according to the instructions supplied.

Exclusions

Shomar Ltd shall not be liable to replace or repair the goods under the terms of the guarantee where:

1. The fault has been caused or is attributable to accidental use, misuse, negligent use or used contrary to the manufacturer's recommendations or where the fault has been caused by power surges or damage caused in transit.
2. The appliance has been used on a voltage supply other than that stamped on the products.
3. Repairs have been attempted by persons other than our service staff.
4. The appliance has been used for hire purposes or non-domestic use.
5. The appliance is second hand.

This guarantee does not confer any rights other than those expressly set out above and does not cover any claims for consequential loss or damage. This guarantee is offered as an additional benefit and does not affect your statutory rights as a consumer.

This guarantee is valid in Ireland and Northern Ireland only.

Powerpoint products are intended for household use only. See usage limitations within the location safety instructions.

Shomar Ltd has a policy of continuous improvement in product quality and design. The company, therefore, reserves the right to change the specification of its models at any time.

Contact Details

The After Sales Division for Powerpoint Appliances is located at the offices of the Brand owner and Distributor – Shomar Ltd,

Unit 9 Western Industrial Estate, Dublin 12, Republic Of Ireland.

Helplines (office hours) & Spare Parts contact number is 01-450 5327 or email service@shomar.ie