

PowerPoint

Free Standing Electric Oven

50x60 cm

P05E1S1W / P05E1S1BL/T05E1S1W

INSTRUCTIONS:

Please read and keep safe for future use.

Table of Contents

Features
..... 3

Safety Instructions..... 4

Installation 6

Fixing to the Wall
..... 8

Electrical Requirements
..... 9

Connecting the Mains Supply
Cable..... 10

Using your Hob
..... 11

Using your Oven
..... 12

Cleaning and Care	13
Replacing the Bulb/Top Tips	15
Disposal of Appliance/Problem Solving	17
Health and Safety	18
Technical Data/ Warranty Information.....	20
Customer Care	22

Features

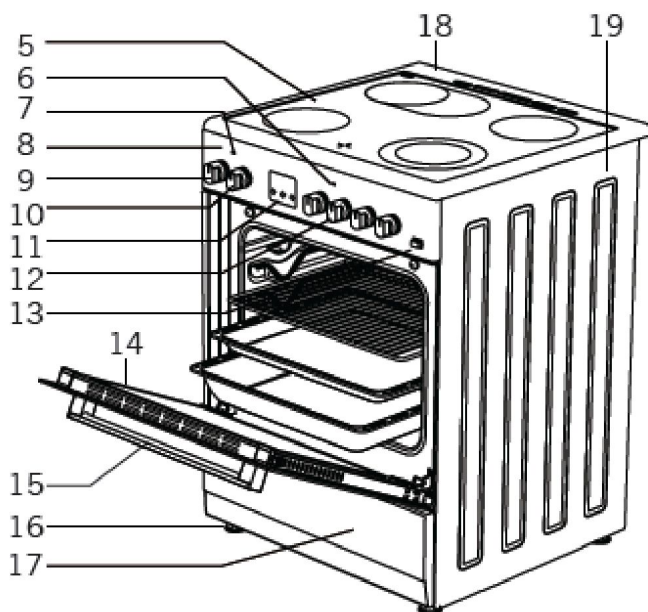

- 5. Solid Hob
- 6. Cooker Section Led Lamp
- 7. Oven Section Led Lamp
- 8. Control Panel
- 9. Thermostat Knob
- 10. Function Knob for Oven

For illustration purposes only. Accessories provided with models P05E1S1W /P05E2S1W

1 Cooking Tray & 1 Wire Grid, inner tray grid & Handle

Safety Instructions

- 12. Regulators For solid Hobs
- 13. Tray Cavity

The use of any electrical appliance requires the following common sense safety rules. There is danger of injury or death to the person and damage to the appliance.

Note: *If the following instructions are not adhered to the warranty will not Be applicable*

- This appliance is not intended for use by persons (including children) with reduced physical, sensory or mental capabilities unless there is a person responsible for their safety present
- Never attempt to repair the appliance yourself
- This appliance is intended to be used in household and residential type environments, it is not suitable for commercial use
- Keep the electrical cable of your cooker away from any heat source and do not let the cable touch the appliance
- Ensure that the electric supply cable is not trapped or damaged during

Installation

- Prior to installation ensure that the electricity voltage and frequency are compatible with your cooker
- In the event that the cable connecting your cooker becomes damaged, it must be replaced by an electrician
- The materials surrounding the appliance (cabinets) must be able to withstand a minimum temperature of 100°C
- The appliance and its accessible parts become hot during use. Care should be taken to avoid touching hot parts
- Cooking on a hob with fat or oil can be dangerous and should not be left unattended
- NEVER try to extinguish a cooking fire with water. Instead switch off the appliance and cover flame with a lid or a fire blanket
- The cooker may topple forward if a child climbs onto the door. Children should be supervised in the kitchen at all times and this

Cooker must be secured to the wall using the fixing chain provided to prevent accidents

- Do not allow children in the kitchen when cooking or while cooker parts may still be hot. Many parts of the cooker will become hot

And present a considerable hazard to children

- When the oven is hot never touch the door

- Before starting to use your appliance ensure that curtains, paper or flammable items are kept away from your appliance. Do not keep flammable materials inside of or around your cooker
- Take care when closing the oven door that there is nothing obstructing it from closing as this may break the glass door
- Position pans over the centre of the burners and turn handles to a safe position where they cannot be knocked or grabbed
- Make sure the cooker control knobs are all in the off position when not in use
- If you do not intend to use your cooker for a long period of time turn off the electric supply to the cooker
- Ensure that the room where your cooker is installed is well ventilated particularly while the cooker is in use. Keep natural ventilation holes open and clear of obstructions or install an extractor hood. Prolonged intensive use of your cooker may call for additional ventilation (by opening a window)
- Do not try to lift or move this cooker by pulling on the door handle
- Ensure that the appliance is switched off before replacing the lamp to avoid the possibility of electric shock
- Your appliance is produced in accordance with all applicable local and International standards and regulations and must only be installed by an authorized service technician
- Do not lean anything on the door while it is open as you may unbalance your appliance or damage the door or its hinges
- Do not hang towels, dishcloths or clothes from the cooker or its handles
- Do not operate the appliance using an external timer or remote control system

Installation Instructions

- This cooker must be installed according to local regulations by a suitably qualified technician
- Carefully unpack the cooker and check for any external visible damage. Do not install or use if it is damaged
- Packaging materials should be collected together and disposed of immediately as they may be harmful to children
- The appliance must be installed on a flat surface
- Surrounding furniture, cabinets and extractor fans should be positioned in accordance with the diagram that follows
- If fitted, the extractor fan must be at least 65cm above the hob. If no fan is fitted the minimum distance between the hob and any cabinet or other structure must be 70cm
- This cooker should not be installed next to a refrigerator or freezer
- The height and level of the appliance can be adjusted by rotating the feet underneath the appliance at each corner. Rotate in a clockwise direction to decrease the height and anti-clockwise to increase the height
- It is not recommended that the cooker is positioned below wall cupboards, as the heat and steam may damage the cupboard and its contents
- Keep all ventilation slots clear of obstruction

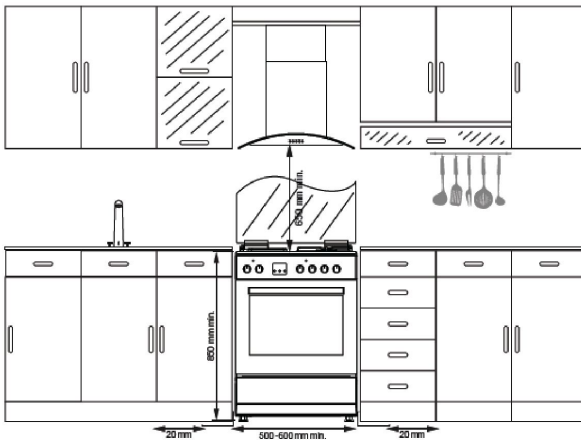

Fixing to the Wall

Before using the appliance fix it securely to the wall using the chain kit provided. Fix to the wall at the back of the cooker. This will prevent the cooker from toppling forward if excess weight is placed on the oven door. As the chains must be attached to the wall using fixings suitable for your wall type, the wall fixings are not supplied with the cooker. Fix the chain to the cooker bracket with the nuts and bolts provided in the fixing kit. It is necessary to ensure the chain is tight to avoid any movement of the cooker once it is operational.

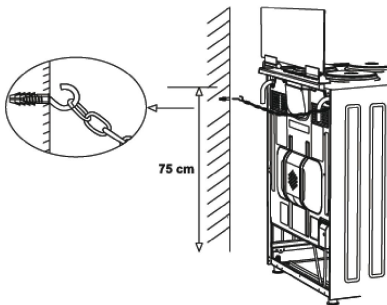

Electrical Requirements

- All electrical connections should be made by a qualified Electrician
- Check that the voltage on the rating plate of your appliance corresponds with your house electricity supply which must be A.C. (Alternating Current)
- Ensure that the mains cable does not get damaged during installation and that it never comes in contact with hot surfaces
- Do not let mains cables come into contact with the appliance door

Electrical details

Rated Voltage: 220 - 240 Vac 50 Hz

Supply Connection: 32 A (double pole switched fused outlet with 3mm contact gap)

Max Rated Inputs: 7.00 kW

Mains Supply Lead: 3 core x 6 mm² (not supplied)

For future reference please record the following information which can be found on the rating plate and the date of purchase which can be found on your sales invoice. The rating plate for your oven can be

Connecting the Mains Supply Cable

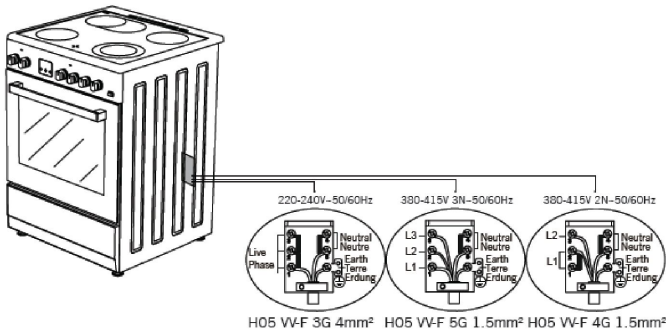

The wires in the mains lead are coloured as follows:

GREEN AND YELLOW: EARTH
BLUE: NEUTRAL
BROWN: LIVE

- Release the cover plate by removing the cover screw
- Loosen the cable clamp
- Connect the mains supply cable to the terminal block on the cooker using the colour code
- Secure the cable clamp
- Check the cable terminals for tightness and ensure that the terminal links are in place, then replace the cover plate and cover screw

Using Your Hob

Control Panels

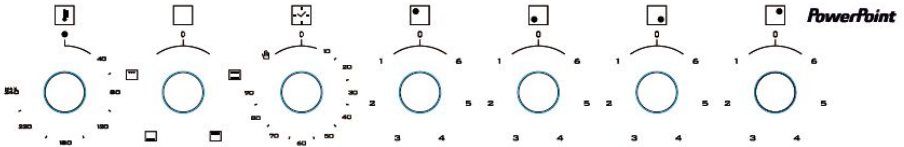

P05E1S1W

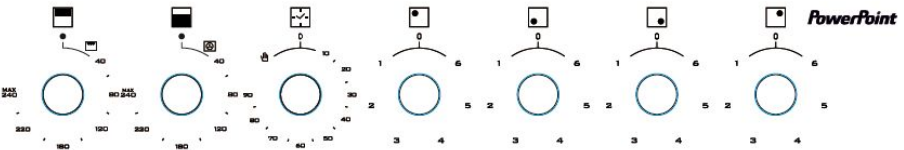

P05E2S1W

WARNING! *There is a risk of burns from residual heat*

Before first use switch on each cooking zone at 6 for 5 minutes. There may be an unusual smell and some smoke, this is the burning off of protective material and not a defect.

Each zone on the hob top is controlled by a knob. The icon above the dial shows which knob controls which burner.









To activate a zone, position the control knob between 1 and 6. 6 is the highest temperature setting and 0 is off. When you have finished cooking on a particular zone, it is important to make sure that the control knob is turned back to 0 (the off position). When turning the hob off, turn the knob clockwise so that the position of the marker on the knob points upwards.

- Saucepans must be positioned exactly on the chosen zones for efficient heating to occur. Pans should have the same diameter as the cooking zone that they are being used on
- Do not use saucepans with rough bottoms as they can scratch the surface of the hob. Use clean, dry pans only
- Cover pans with a lid to permit cooking at a lower heat
- Cook vegetables and potatoes, etc. in as little water as possible to reduce cooking time
- Food or liquid that has a high sugar content may damage the hob top if it comes into contact with the hob surface. Any spillages should be wiped up immediately
- Before frying foods, dry the food and gently place into the hot oil
- Do not cover a pan of heating oil
- Position pans and saucepans so that their handles are not over the hob to prevent the heating of handles
- Operating a cooking zone without a pan or saucepan on it will cause damage to the appliance. Turn off each cooking zone after cooking is complete
- Do not place plastic items on surface of the hob

Using Your Oven

When using your oven for the first time your oven may give off an unusual smell from the heating elements and insulation materials. This is normal for

new cookers. To eliminate this smell run the oven at 240 degrees for 40-60 minutes with the oven empty. When cool, clean with warm soapy water.

	P05E1S1W		P05E2S1W
	Top + Bottom heating element		Turbo heating + Fan
	Lamp		Lamp
	Top heating element		Electrical timer
	Oven burner / Bottom heating element		Grill heating element

In order to operate the oven the thermostat must be adjusted to the desired temperature. In order to operate the oven, the timer switch should be set to the desired cooking time.

Turn the oven function selection knob clockwise to select the mode of cooking required.

- Do not use aluminium foil to line the bottom of the oven or grill tray
- Food should not be placed inside the cavity until the correct cooking temperature has been reached
- Refer to food packaging for guidance on cooking temperatures and times. Once familiar with the performance of your appliance, temperatures and times can be varied to suit personal preference
- Check that any unused accessories are removed from the oven
- Place cooking trays in the centre of the oven and leave gaps between the trays to allow air to circulate
- Keep oven door closed for all cooking functions
- Don't place cookware on bottom of oven, use shelves

Cleaning and Care

Cleaning the Oven

- Do not clean oven using caustic creams, abrasive cleaning powders, wire wool or hard tools to clean any parts of this cooker
- Enamelled parts of the oven can be damaged if excess cleaning liquids are not immediately removed
- Always turn the appliance off before cleaning and disconnect from your mains supply
- Clean the interior parts of the oven with a soapy cloth, rinse and dry thoroughly with a soft cloth
- Clean the glass surfaces with glass cleaning agents
- Never use flammable agents when cleaning your oven
- Do not clean your oven with a steam cleaner
- Do not wash any part of your oven in a dishwasher
- Clean spillages immediately
- Remove the glass front door by unscrewing the fixings using a screwdriver, remove the inside glass, clean and rinse it. After drying replace the seal properly and re-install the glass
- Cleaning of the oven should be carried out on a regular basis, clean the interior after each use. Fat accumulation or other food remains may result in a fire
- Care must be taken when cleaning between the door glass and inside the inner frame as the edges may be sharp
- Cleaning must only be carried out when the oven is cool
- The oven should be thoroughly cleaned before it is operated for the first time and after each use. This will avoid residual food stuffs becoming baked onto the oven cavity. After residues have been baked on several times, they are far more difficult to remove
- The oven cavity should only be cleaned with warm soapy water, using either a sponge or soft cloth
- Outer parts of the oven should only be cleaned with warm soapy Water using either a sponge or soft cloth
- Any damage that is caused to the appliance by a cleaning product will not be rectified even if the appliance is within the guarantee period

- Do not use abrasive cleaners or sharp metal scrapers to clean the oven door glass as it may shatter

Removing the Oven Door for Cleaning:

To facilitate the cleaning of the inside of the cooker and the outer frame of the oven, the door can be removed as follows:-

- Press the plastic latches on both left and right sides as shown in Figure 1 and
- Pull the profile towards you as shown in Figure 2
- Then remove the inner-glass as shown in Figure 3

If required the middle glass can be removed in the same way. After cleaning and maintenance are done, remount the glass and the profile in reverse Order.

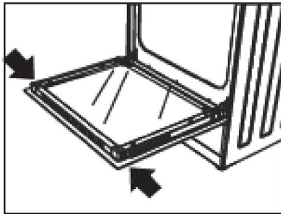

Fig. 1

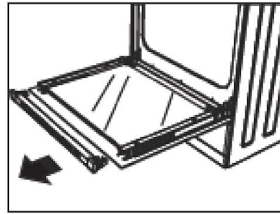

Fig. 2

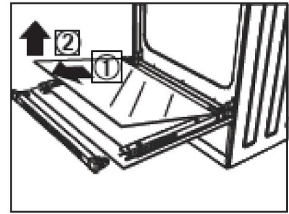

Fig.3

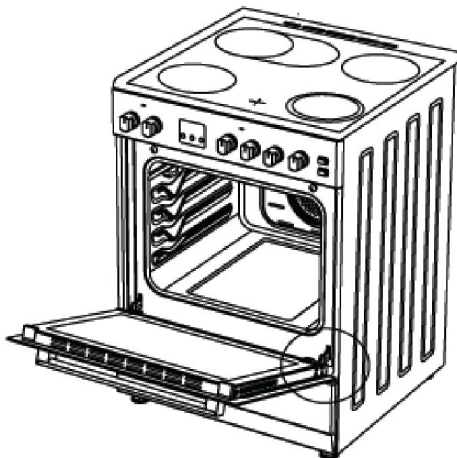

Figure 4

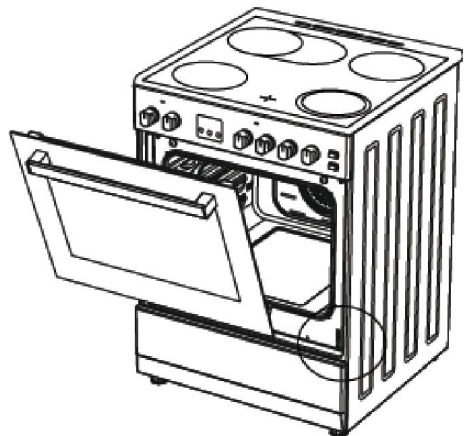

Figure 5

- Open door, unlock by pulling the hinge lock upwards with a screw driver
- Bring the hinge lock to the widest angle, bring both hinges connecting the oven door to the same position
- Close the oven door to lean on the hinge lock
- To remove the oven door, pull it upwards by holding with both hands when close to the closed position

Cleaning the Hob Top

- Remove any residues of cleaning agents with warm soapy water
- Abrasive cleaners or sharp objects will damage the hob surface, use warm soapy water
- It is easier to clean some deposits whilst the hob surface is still warm, but be careful of burns
- Wipe the hob over with a damp cloth and a little washing up liquid after each use
- Dry the appliance by rubbing the surface with a clean cloth
- To maintain the solid plates remove spillages using a soft brush, plastic or nylon scourer and warm water
- To keep the solid plates in good condition put a little olive oil onto a kitchen towel and rub it onto the surface of the plate. Alternatively you can use a hotplate conditioner. If the solid plates are not maintained regularly with olive oil or a hotplate conditioner they may rust

Replacing the Oven Bulb

IMPORTANT: The oven must be disconnected from your mains supply before you attempt to either remove or replace the oven bulb.

- Remove all oven shelves and the drip tray
- Unscrew the lamp cover by turning anti-clockwise
- Unscrew the bulb and replace with a 15 W bulb
- Screw the lamp cover back into its original position

Top Tips

- Avoid using pans on the hob that are unstable as they may be easily tipped over
- Use pans that have sufficient capacity for the amount of food being cooked so that they don't boil over
- Use dark coloured enamelled cookware to maximise heat transmission
- Always position pans centrally over each hob zone
- Select the burner which is suitable for the size of the bottom of the pot to be used
- Thick based pots will conduct heat more effectively
- When moving a pan from one zone to another, lift the pan and do not slide it
- Ensure that the base of the pan is dry before placing it on the burner
- Keep children and animals out of reach of the cooker during and after cooking
- After use the hob remains very hot for a prolonged period of time, do not touch or place any object on top of the hob
- Never place cutlery or lids on the hob as they will get hot and could cause serious burns
- Do not open oven door too frequently
- When deep fat frying never fill the pan more than one third full of

And do not use a lid; Never leave oil unattended

- Fry small quantities of frozen food at a time as the temperature lowers causing the food to be greasy if too large a quantity is cooked
- Dry food before lowering into hot oil
- Keep the outside of your pans free from streaks of oil
- Do not store chemicals, food stuffs, pressurised containers in or

on the cooker or in cabinets immediately above or next to the cooker

- Do not heat unopened food containers as pressure can build

Up which may cause the container to burst

- Do not place flammable or plastic items on or near the hob

Zones

- Do not allow fat or oil to build up in the oven trays, grill pan or on the

Oven base

- Do not place pans or baking trays directly on the base of the oven cavity, or line it with aluminium foil
- Do not grill food containing fat without using the grill trivet. The Grill trivet should never be covered with aluminium foil

Grill trivet should never be covered with aluminium foil

- Do not place hot enamel parts in water, leave them to cool first
- Do not allow electrical fittings or cables to come into contact

With areas on the appliance that get hot

- Be careful if using alcohol as a cooking ingredient, there is a danger of ignition
- Extend baking times by 10 – 15 minutes if you are baking on more than one level

Disposal of Electrical Appliances

Dispose of used electrical appliances in an environmentally friendly manner. This cooker bears the symbol for waste electrical and electronic equipment (WEEE). This means that this equipment must be handled in accordance with European Directive 2002/96/EC for recycling to minimise damage to the environment. Before disposing of the appliance, cut off the power cable plug and remove the door to avoid accidents.

Problem Solving

Fault Oven doesn't heat

Cause fuse may be blown, check that you have selected a cooking function and temperature

Fault Lamp doesn't function

Cause No electricity supply or bulb is faulty

Fault There is condensation in the oven

Cause Steam and condensation are a result of cooking food with high water

Content. Do not leave food in the oven to cool after it has been cooked. Use a covered container, where practical, when cooking to Reduce the amount of condensation that forms.

Health & Safety

Location

- This appliance is intended to be used in household and residential type environments. It is not suitable for use in shops, offices or other working environments
- Do not use outdoors
- Do not place appliance on a highly polished wooden surface as damage may occur to the surface
- This appliance should not be used in a garage, conservatory, annex, shed or out-house

Personal Safety

- To protect against the risk of electric shock ensure the electrical connections are kept dry
- This appliance is not intended for use by persons (including children) with reduced physical, sensory or mental capabilities
- Use heat resistant gloves to remove hot dishes from the oven
- Stand back when opening oven door to allow the heat to disperse
- Do not place heavy objects on the oven door or lean on the oven door when it is open, as this can cause damage to the hinges

Children

- Children should be supervised to ensure that they do not play with this appliance

- Teach children to be aware of dangers in the kitchen
- Do not allow children to play with the appliance or tamper with the controls

Other Safety Considerations

- Do not operate any appliance with a damaged cord or after the appliance malfunctions or has been damaged in any manner
- Do not use the appliance for anything other than its intended purpose
- If the appliance is dropped or damaged in any manner, return the appliance to the nearest authorized dealer or after-sales service centre for examination, repair, electrical or mechanical adjustment

How to Extinguish a Fire

1. Turn off the power.
2. Cover the pan with a fire blanket, lid or damp cloth. This will smother the flames and extinguish the fire.
3. Leave the pan to cool for at least an hour before attempting to move it. Injuries are often caused by picking up a hot pan.

WARNING: Never Use Water to Extinguish Oil or Fat Pan Fires.

Warning: Risk of Burns! Never touch hot burners or the inside of the Oven. Always use heat resistant gloves

Technical Data

TECHNICAL FEATURES OF YOUR OVEN

SPECIFICATIONS	50x55
Outer Width	500mm
Outer Depth	560mm
Outer Height	855mm
Lamp Power	15W
Thermostat	
Bottom Heating Element	1000W
Top Heating Element	800W
Turbo Heating Element	-----
Grill Heating Element	1500W

Supply Voltage	220-240/380-415V,50/60 Hz
----------------	---------------------------

Warranty Information

Registering Your 2 Year Guarantee

Your standard one year guarantee is extended for an additional 1 year when you register the product within 28 days of purchase with the supplier Shomar Ltd. If you do not register the product with Shomar Ltd within 28 days, your product is guaranteed for 1 year. To validate your 2 year guarantee register with us by completing the form attached and posting it to Shomar Ltd.

Please note that the 2 year guarantee is only available in Ireland and the UK only.

Please refer to the one year guarantee for more information.

One Year Guarantee

It is important to retain the retailer's receipt as proof of purchase. Staple your receipt to this back cover for future reference.

Please quote the following information if the product develops a fault. These numbers can be found on the product.

Model no.

Serial no.

Subject to the exclusions set out below (see Exclusions), the faulty appliance will then be repaired or replaced. If for any reason, this item is replaced during the guarantee period, the guarantee on the new item will be calculated from original purchase date. Therefore it is vital to retain your original till receipt or invoice to indicate the date of initial purchase.

To qualify for the 1 year guarantee, the appliance must have been used according to the instructions supplied.

Exclusions

Shomar Ltd shall not be liable to replace or repair the goods under the terms of the guarantee where:

1. The fault has been caused or is attributable to accidental use, misuse, negligent use or used contrary to the manufacturer's recommendations or where the fault has been caused by power surges or damage caused in transit.
2. The appliance has been used on a voltage supply other than that stamped on the products.

3. Repairs have been attempted by persons other than our service staff.
4. The appliance has been used for hire purposes or non-domestic use.
5. The appliance is second hand.

This guarantee does not confer any rights other than those expressly set out above and does not cover any claims for consequential loss or damage. This guarantee is offered as an additional benefit and does not affect your statutory rights as a consumer. This guarantee is valid in Ireland and the UK only.

PowerPoint products are intended for household use only. See usage limitations in "safety instructions". Shomar Ltd has a policy of continuous F7F7the right to change the specification of its models at any time.

Customer Care

The After Sales Division for PowerPoint Appliances is located at the offices of the Brand owner and Distributor –

Shomar Ltd, Unit 9 Western Industrial Estate, Dublin 12, Republic Of Ireland.

Helplines (office hours) & Spare Parts contact number is 01-450 9150 or email service@shomar.ie

