



# MAVERICK

Original Instruction



EU-H1-MAVE



Read Operator's Manual

# HELMETS SAVE LIVES!

Always wear a properly fitted helmet that complies with CPSC or CE safety standards when you ride your scooter.

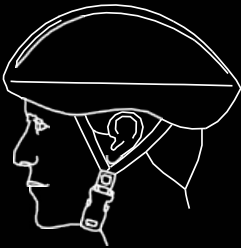

**Correct Fitting:**

Make sure your helmet covers your forehead.



**Incorrect Fitting:**

Forehead is exposed and vulnerable to serious injury.

# **WARNING!**

## **PLEASE READ THE USER MANUAL THOROUGHLY.**

**Failure to follow the basic instructions and safety precautions listed in the user manual can lead to damage to your Maverick, other property damage, serious bodily injury, and even death.**

Thank you for purchasing the Hover-1 Maverick Electric Scooter. Please read all instructions carefully before using and retain this manual for future use and reference.

This manual applies to the Maverick Electric Scooter.

- In order to avoid dangers that are caused by collisions, falls, and loss of control, please learn how to ride the Maverick safely.
- You can learn operating skills by reading the product manual and watching videos.
- This manual includes all operating instructions and precautions, and users must read it carefully and follow the instructions.
- Hover-1 can not be held liable for damage or injury caused by failure to understand and follow the warnings and instructions in this manual.

## **ATTENTION**

1. Use only the supplied charger with this scooter.

Charger Manufacturer: Shenzhen Fuyuandian Power Co. Ltd

Model: FY0184200400B

The battery charger FY0184200400B is only to be used with the E-Scooter EU-H1-MAVE.

If the power supply cord of the charger is damaged, in order to avoid hazards, it must be replaced by Hover-1 only or one of Hover-1's service agents.

2. The operating temperature range of the Maverick is 32-104° F (0-40° C).

3. Do not ride on icy or slippery surfaces.

4. Read the user manual and warning labels before riding.

5. Store the Maverick in a dry, ventilated environment.

6. When transporting the Maverick, avoid violent crashes or impact.

## **LOW TEMPERATURE WARNING**

Low temperature will affect the lubrication of moving parts inside the Maverick scooter, increasing internal resistance. At the same time, in low temperatures, the discharge capacity and the capacity itself of the battery will be significantly decreased.

Use caution when riding the Maverick in cold temperatures (below 40 degrees F).

Doing so may increase the risk of mechanical failures of the scooter, which may lead to damage to your Maverick, other property damage, serious bodily injury and even death.

## **SAFETY INSTRUCTIONS**

- Keep the Maverick away from heat sources, direct sunlight, humidity, water and any other liquids.
- Do not operate the Maverick if it has been exposed to water, moisture or any other liquids to prevent against electric shock, explosion and/or injury to yourself and damage to the Maverick.
- Do not use the Maverick if it has been dropped or damaged in any way.
- Repairs to electrical equipment should only be performed by the manufacturer. Improper repairs voids the warranty and may place the user at serious risk.
- Do not puncture or harm the exterior surface of the product in any way.
- Keep the Maverick free from dust, lint, etc.
- Do not use this Maverick for anything other than its intended use or purpose. Doing so may damage the Maverick or lead to property damage, injury or death.
- This product is not a toy. Keep out of reach of children.
- Do not expose batteries, battery pack, or batteries installed to excessive heat, such as direct sunlight, or open flame.
- Do not allow hands, feet, hair, body parts, clothing or similar articles to come in contact with moving parts, wheels or drivetrain, while the engine is running.

- Do not operate or allow others to operate the Maverick until the user understands all instructions, warnings and safety features described in this manual.
- Check with your doctor if you have a medical condition that could affect your ability to use the Maverick.
- Persons with head, back or neck ailments or prior surgeries to those areas of the body are not recommended to use the Maverick.
- Do not operate if you are pregnant, have a heart condition, or have both.
- The Maverick can be used by children aged of 8 years old and above and persons with reduced physical, sensory or mental capabilities or lack of experience and knowledge if they have been given supervision or instruction concerning use of the Maverick in a safe way and understand the hazards involved. Children shall not play with the Maverick. Cleaning and user maintenance shall not be made by children without supervision.



## NOTES:

In this manual, the above symbol with the word "NOTES" indicates instructions or relevant facts the user should remember prior to using the device.



## CAUTION!

In this manual, the above symbol with the word "CAUTION" indicates a hazardous situation which, if not avoided, can cause minor or moderate injury.



## WARNING!

In this manual, the above symbol with the word "WARNING" indicates a hazardous situation which, if not avoided, can cause death or serious injury.

## SERIAL NUMBER

Please keep the serial number on file for warranty claims as well as proof of purchase.



## WARNING!

WARNING: Prolonged Exposure to UV Rays, Rain and the Elements  
May Damage the Enclosure Materials.  
Store Indoors When Not in Use.

# INTRODUCTION

The Hover-1 Maverick is a personal transporter. Our technology and production processes are developed with strict testing for each Maverick scooter. Operating the Maverick without following the contents of this manual may lead to damage to your Maverick or bodily injury.

This manual is designed to give you the information you need for the safe operation and maintenance of your Maverick. Please read it thoroughly before riding your Maverick.

## PACKAGE CONTENTS

- Hover-1 Maverick Electric Scooter
- Wall Charger
- Operation Manual

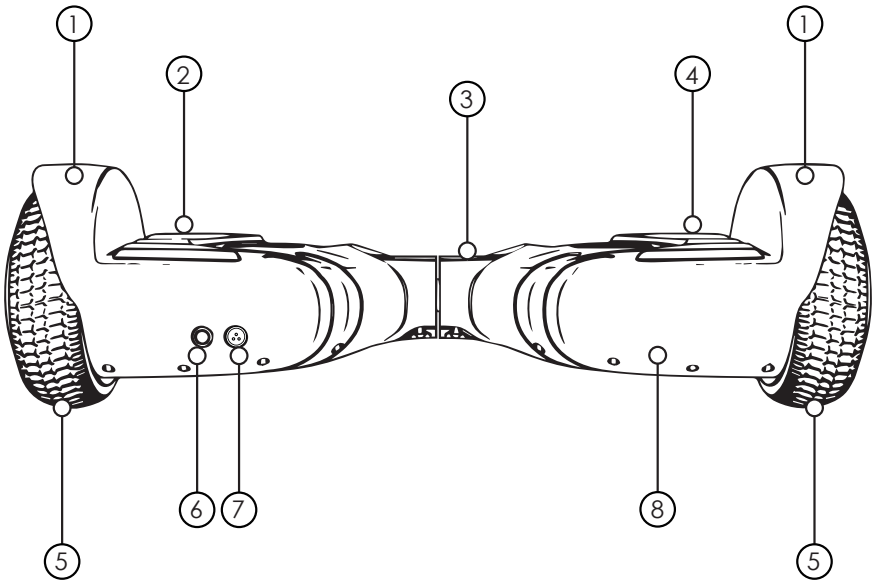

## FEATURES/PARTS

- |                      |                              |
|----------------------|------------------------------|
| 1. Fender            | 5. Tire                      |
| 2. Left Foot Mat     | 6. Power Button              |
| 3. Battery Indicator | 7. Charge Port               |
| 4. Right Foot Mat    | 8. Protective Chassis Casing |

## OPERATING PRINCIPALS

The Maverick uses digital electronic gyroscopes and acceleration sensors to control balance and motion, depending on the user's center of gravity. The Maverick also uses a control system to drive the motors that are located within the wheels. The Maverick has a built-in inertia dynamic stabilization system that can help assist with balance when moving forward and backwards, but not while turning.

TIP – To increase your stability, you must shift your weight in order to overcome the centrifugal force during turns, especially when entering a turn at higher speeds.

## WARNING

Any Maverick that does not work properly can cause you to lose control and fall. Inspect the entire Maverick thoroughly before every ride, and do not ride it until any problems have been corrected.

## SPECIFICATIONS

Model:	Hover-1™ Maverick (EU-H1-MAVE)
Net Weight:	15 lbs (6.8 kg)
Load:	44-160 lbs (20-72.5 kg)
Max Speed:	Up to 7 mph (11.3 km/h)
Max Distance Range:	Up to 3 miles (4.8 km)
Max Incline Angle:	10°
Minimum Turning Radius:	0°
Maximum Continuous Rated Power:	200 W
Charge Time:	Up to 6 hours
Battery Type:	Lithium-ion
Battery Voltage:	36 V
Battery Capacity:	2.0Ah
Power Requirement:	AC 100-240V, 50/60Hz
Ground Clearance:	1.5 Inches (3.81 cm)
Platform Height:	4.5 Inches (11.43 cm)
Tire Type:	Non-Pneumatic Solid Tires

# CONTROLS AND DISPLAY

**PLEASE READ THE FOLLOWING INSTRUCTIONS CAREFULLY**

## **TURNING YOUR DEVICE ON/OFF**

**Power On:** Take your Maverick out of the box and place it flat on the floor. Press the power button (located on the rear of your Maverick) once. Check the LED indicator (located in the center of your Maverick). The battery indicator light should be lit, indicating the Maverick is powered on.

**Power Off:** Press the power button once.

## **MAT SENSOR**

There are four sensors under the foot mats on your Maverick.

When riding the scooter, you must ensure you are stepping on the foot mats. Do not step or stand on any other area of your scooter.

The Maverick may vibrate or spin in one direction, if weight and pressure are applied to only one foot mat.

## **BATTERY INDICATOR**

The display board is located in the middle of the Maverick.

- Green LED Light indicates the hoverboard is fully charged.
- Red flashing LED light and beeping indicates low battery.
- Yellow light indicates the board is charging.

When the LED light turns red, please recharge the Maverick.

## **RUNNING INDICATOR**

When the operator triggers the foot mats, the Running Indicator LED will light up, which means that the system enters the running state.

When the system has an error during operation, the running LED light will turn red (for more details see SAFETY ALERTS).



# BEFORE RIDING

It is important that you fully understand all elements of your Maverick. If these elements are not used correctly, you will not have full control of your Maverick. Before you ride, learn the functions of the various mechanisms on your scooter.

Practice using these elements of your Maverick at slower speeds in a flat, open area before taking the Maverick out in public areas.

## PRE-RIDE CHECKLIST

Ensure that your Maverick is in proper working order each and every time you ride. If a part of the scooter does not function correctly, please contact our Customer Support Center.

### **WARNING**

Any Maverick that does not work properly can cause you to lose control and fall. Do not ride a Maverick with a part that is damaged; replace the damaged part before riding.

- Ensure the battery is fully charged before riding your scooter.
- Ensure that the screws on the front and back tires are locked firmly before each ride.
- Please wear all appropriate safety and protective gear as previously mentioned in the User Manual before operating your Maverick.
- Make sure to wear comfortable clothes and flat closed-toe shoes when operating your Maverick.
- Please carefully read the User Manual, which will assist in explaining the basic working principles and provide tips on how to best enjoy your experience.

# SAFETY PRECAUTIONS

Different localities and countries have different laws governing riding on public roads, and you should check with local officials to ensure you are complying with these laws.

Hover-1 is not liable for tickets or violations given to riders who do not follow local laws and regulations.

- For your safety, always wear a helmet that meets CPSC or CE safety standards. In the event of an accident, a helmet can protect you from serious injury and in some cases, even death.
- Obey all local traffic laws. Obey red and green lights, one-way streets, stop signs, pedestrian crosswalks, etc.
- Ride with traffic, not against it.
- Ride defensively; expect the unexpected.
- Give pedestrians the right-of-way.
- Do not ride too close to pedestrians and alert them if you intend to pass them from behind.
- Slow down at all street intersections and look to the left and right before crossing.

Your Maverick is not equipped with reflectors. It is not recommended that you ride in conditions of low visibility.

## **WARNING**

When you ride in low-visibility conditions such as fog, dusk, or night, you might be difficult to see, which could lead to a collision. In addition to keeping your headlight on, wear bright, reflective clothing when riding in poor lighting conditions.

Think about safety when you ride. You can prevent many accidents if you think about safety. Below is a helpful checklist for Compact riders.

## SAFETY CHECKLIST

- Do not ride above your skill level. Ensure you have had enough practice with all functions and features of your Maverick.
- Before stepping on your Maverick, make sure it is placed flat on level ground, the power is on, and the Running Indicator light is green. Do not step on if the Running Indicator light is red.
- Do not try to open or modify your Maverick. Doing so, voids the manufacturer warranty and may cause your Maverick to fail, resulting in injury or death.
- Do not use the Maverick in a manner that would put people or property in danger.
- If riding near others, keep a safe distance to avoid collision.
- Be sure to keep your feet on the pedals at all times. Moving your feet off your Maverick while driving is dangerous and may cause the Maverick to stop or veer sideways.
- Do not operate the Maverick while under the influence of drugs and/or alcohol.
- Do not operate the Maverick when you are restless or sleepy.
- Do not ride your Maverick off of curbs, ramps, or attempt to operate in a skate park, empty pool, or in any way similar to a skateboard or scooter. The Maverick IS NOT A SKATEBOARD. Misuse of your Maverick, voids the manufacturer warranty and may lead to injury or damage.
- Do not continuously spin in place, it will cause dizziness and increases risk of injury.
- Do not abuse your Maverick, doing so can damage your unit and cause failure to the operating system leading to injury. Physical abuse, including dropping your Maverick, voids the manufacturer warranty.
- Do not operate in or near puddles of water, mud, sand, stones, gravel, debris or near rough and rugged terrain.
- The Maverick can be used on paved surfaces that are flat and even. If you encounter uneven pavement, please lift your Maverick over and past the obstruction.

- Do not ride in inclement weather: snow, rain, hail, sleet, on icy roads or in extreme heat or cold.
- Bend your knees when riding on bumpy or uneven pavement to absorb the shock and vibration and help you keep your balance.
- If you are unsure if you can safely ride on a specific terrain, step off and carry your Maverick. ALWAYS BE ON THE SIDE OF CAUTION.
- Do not attempt to ride over bumps or objects greater than ½ in. even when prepared and bending your knees.
- PAY ATTENTION - look at where you are riding and be conscious of the road conditions, people, places, property and objects around you.
- Do not operate the Maverick in crowded areas.
- Operate your Maverick with extreme caution when indoors, especially around people, property, and narrow spaces.
- Do not operate the Maverick while talking, texting, or looking at your phone.
- Do not ride your Maverick where it is not permitted.
- Do not ride your Maverick near motor vehicles or on public roads.
- Do not travel up or down steep hills.
- The Maverick is intended for use by a single individual, DO NOT attempt to operate the Maverick with two or more people.
- Do not carry anything while riding the Maverick.
- Individuals with lack of balance should not attempt to operate the Maverick.
- Pregnant women should not operate the Maverick.
- The Maverick is recommended for riders ages 8 and older.
- At higher speeds, always take into consideration longer stopping distances.
- Do not step forward off of your Maverick.

- Do not attempt to jump on or off your Maverick.
- Do not attempt any stunts or tricks with your Maverick.
- Do not ride the Maverick in dark or poorly lit areas.
- Do not ride the Maverick off road, near or over potholes, cracks or uneven pavement or surfaces.
- Keep in mind that you are 4.5 inches (11.43 cm) taller when operating the Maverick. Make sure to go through doorways safely.
- Do not turn sharply, especially at high speeds.
- Do not step on the fenders of the Maverick.
- Avoid driving the Maverick in unsafe places, including near areas with flammable gas, steam, liquid, dust or fiber, which could cause fire and explosion accidents.
- Do not operate near swimming pools or other bodies of water.

**WARNING!** As with any mechanical component, a vehicle is subject to high stresses and wear. The various materials and components may react differently to wear or fatigue. If the expected service life for a component has been exceeded, it may break suddenly, therefore risking causing injuries to the user. Cracks, scratches and discoloration in the areas subject to high stresses indicate that the component has exceeded its service life and should be replaced.

**WARNING:** Keep plastic covering away from children to avoid suffocation.

 **WARNING:**

To reduce the risk of injury, adult supervision is required. Never use in roadways, near motor vehicles, on or near steep inclines or steps, swimming pools or other bodies of water; always wear shoes, and never allow more than one rider.

# RIDING YOUR MAVERICK

**FAILURE TO FOLLOW ANY OF THE FOLLOWING SAFETY PRECAUTIONS CAN AND MAY LEAD TO DAMAGE TO YOUR MAVERICK, VOID YOUR MANUFACTURER WARRANTY, LEAD TO PROPERTY DAMAGE, CAUSE SERIOUS BODILY INJURY, AND CAN LEAD TO DEATH.**

Before using your Maverick, be sure to familiarize yourself with the operating procedures.

## OPERATING YOUR MAVERICK

Make sure the Maverick is fully charged before initial use. For charging instructions, please follow details under CHARGING YOUR MAVERICK.

Stand directly behind your Maverick and place one foot on the corresponding foot mat (as described in the diagram below). Keep your weight on the foot which is still on the ground, otherwise the Maverick may begin to move or vibrate, making it difficult to step on evenly with your other foot. When you are ready, shift your weight to the foot already placed on the Maverick and step on with your second foot quickly and evenly (as described in the diagram below).

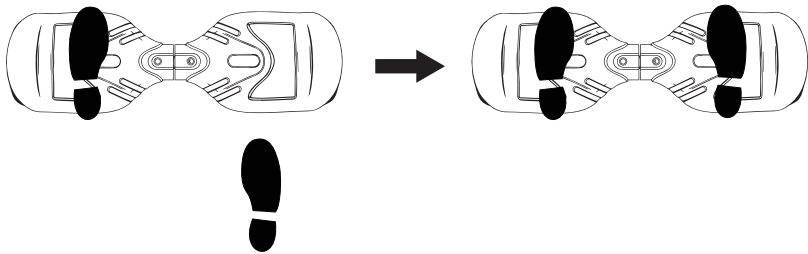

## NOTES:

Stay relaxed and step on quickly, confidently and evenly. Imagine climbing stairs, one foot, then the other. Look up once your feet are even. The Maverick may vibrate or spin in one direction, if weight and pressure are applied to only one foot mat. THIS IS NORMAL.

Find your center of gravity. If your weight is distributed correctly on the foot mats and your center of gravity is level, you should be able to stand on your Maverick just as if you were standing on the ground.

On average, it takes 3-5 minutes just to get comfortable standing on your Maverick and maintaining proper balance. Having a spotter will help you feel more secure. The Maverick is an incredibly intuitive device; it senses even the slightest bit of motion, so having any anxiety or reservation about stepping on may cause you to panic and trigger unwanted movement.

When you first begin using your Maverick, the fastest way to move in your desired direction is to focus in that direction. You will notice that just thinking about which way you would like to go will shift your center of gravity, and that subtle movement will propel you in that direction.

Your center of gravity determines which direction you move, accelerate, decelerate, and come to a complete stop. As described in the diagram below, tilt your center of gravity in the direction you wish to move.

To turn, focus on the direction you wish to turn and stay relaxed.

**⚠ WARNING**

Do not turn sharply or at high speeds to avoid danger. Do not turn or ride quickly along slopes, as it may cause injury.

As you get comfortable on the Maverick, you will notice it becomes easier to maneuver. Remember at higher speeds, it is necessary to shift your weight to overcome the centrifugal force.

Bend your knees if you encounter bumps or uneven surfaces, then dismount and carry your Maverick to a safe operating surface.

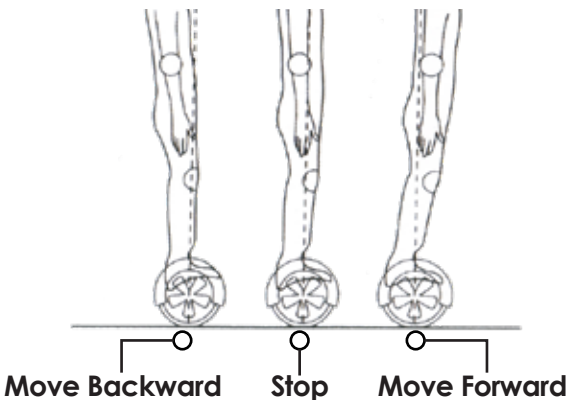



## NOTES:

Try staying relaxed and focus on finding your center of gravity to maintain full control of your Maverick.

Dismounting your Maverick can be one of the easiest steps, yet when done incorrectly, may cause you to fall. To properly dismount, from a stopped position, lift one leg up and set your foot back down on the ground (STEPPING BACK). Then step off completely as described in the following diagram.

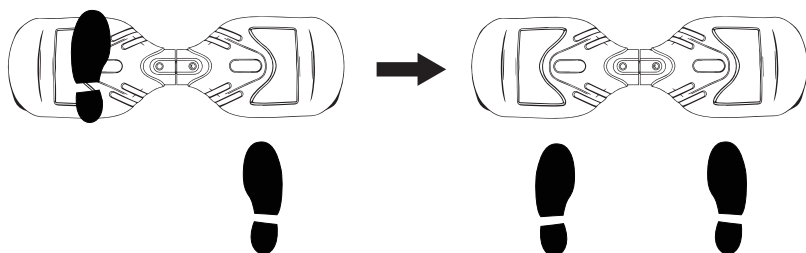

## WARNING

Make sure to lift your feet completely off the foot mat to clear the Maverick when stepping back to dismount. Failure to do so may send the Maverick into a tailspin.

### WEIGHT AND SPEED LIMITATIONS

Speed and weight limits are set for your own safety. Please do not exceed the limits listed here in the manual.

- Maximum Weight: 160 lbs
- Minimum Weight: 44 lbs
- Maximum Speed: Up to 7 mph



## **WARNING**

Overweight exertion on the Maverick may increase possibility of injury or product damage.

## **NOTES:**

To prevent injury, when max speed is reached, the Maverick will beep to alert the user and tilt the rider slowly back.

## **OPERATING RANGE**

The Maverick can travel a distance up to 3 miles on a fully charged battery in ideal conditions. The following are some of the major factors that will affect the operating range of your Maverick.

- **Terrain:** Riding distance is highest when riding on a smooth, flat surface. Riding uphill and/or on rough terrain will reduce distance significantly.
- **Weight:** A lighter user will have further range than a heavier user.
- **Ambient temperature:** Please ride and store the Maverick under recommended temperatures, which will increase riding distance, battery life, and overall performance of your Maverick.
- **Speed and Riding Style:** Maintaining a moderate and consistent speed while riding produces maximum distance. Traveling at high speeds for extended periods, frequent starts and stops, idling and frequent acceleration or deceleration will decrease overall distance.

## **BALANCE & CALIBRATION**

**If your Maverick is unbalanced, vibrating, or not turning properly, you can follow the below steps to calibrate it.**

- First, place the Maverick on a flat, horizontal surface such as the floor or a table. The foot mats should be even with each other and not tilted forward or backward. Make sure the charger is not plugged in and the board is turned off.
- Press and hold the ON/OFF button for a total of 15 seconds. The scooter will turn on, lighting the battery indicator on the board.
- After the light flashes 5 times consecutively you may release the ON/OFF button.
- Turn the board off and then turn the board back on. Calibration will now be completed.

# SAFETY ALERTS

While riding your Maverick, if there is a system error or improper operation performed, the Maverick will prompt the user in a variety of ways.

You will notice the Running Indicator Light will turn RED and you will hear a beep sound alerting you to take precaution and cease operation, which may make the device stop suddenly.

The following are common occurrences where you will hear the Safety Alerts. These notices should not be ignored, but appropriate action should be taken to correct any illegal operation, failure or errors.

- Unsafe riding surfaces (uneven, too steep, unsafe, etc.)
- When you step on the Maverick, if the platform is tilted more than 10 degrees forward or backward.
- Battery voltage is too low.
- The Maverick is still charging.
- During operation, the platform self initiates to tilt due to excess speed.
- Overheating, or motor temperature is too high.
- The Maverick has been rocking back and forth for over 30 seconds.
- If the system enters protection mode, the alarm indicator will light up and the board will vibrate. This typically occurs when the battery is about to run out of power.
- **If the platform is tilted forward or backward more than 10 degrees, your Maverick will power off and stop suddenly, possibly causing the rider to lose balance or fall off.**
- If any or both tires are blocked, the Maverick will stop after 2 seconds.
- When the battery level has depleted below protection mode, the

Maverick engine will power off and stop after 15 seconds.

- While sustaining a high discharge current during use (such as driving up a steep slope for a long period of time), the Maverick engine will power off and stop after 15 seconds.

## **WARNING**

When the Maverick turns off during a Safety Alert, all operation systems will halt. Do not continue attempting to ride the Maverick when the system initiates a stop. Turn your Maverick off and back on to unlock it from a Safety Lock.

# CHARGING YOUR MAVERICK

## CHARGING THE MAVERICK

- Ensure that the charging port is clean and dry.
- Make sure that there is no dust, debris or dirt inside the port.
- Plug the charger into a grounded wall outlet. The charging indicator light ON THE CHARGER will be green.
- Connect the cable with the power supply (100V ~ 240V; 50/60 Hz).
- Align and connect the 3-pin charging cable into the charging port of the Maverick. **DO NOT FORCE THE CHARGER INTO THE CHARGE PORT, AS THIS MAY CAUSE THE PRONGS TO BREAK OFF OR PERMANENT DAMAGE TO THE CHARGE PORT.**
- Once attached to the board, the charging indicator light ON THE CHARGER should change to RED, indicating that your device is now being charged.
- When the RED indicator light on your charger turns to GREEN, then your Maverick is fully charged.
- A full charge may take up to 6 hours. While charging, you will see a yellow flashing light on the scooter, which also indicates charging. Do not charge for more than 7.5 hours.
- After fully charging your Maverick, unplug the charger from your Maverick and from the power outlet.
- Power off your Maverick when charging.

# BATTERY CARE / MAINTENANCE

## BATTERY SPECIFICATIONS

Battery Type: Rechargeable lithium-ion battery

Charge Time: Up to 6 hours

Voltage: 36V

Initial Capacity: 2.0 AH

## BATTERY MAINTENANCE

The lithium-ion battery is built into the Maverick. Do not disassemble the Maverick to remove the battery or attempt to separate it from the Maverick.

- Use only the charger and charging cable supplied by Hover-1. Use of any other charger or cable may lead to damage to the product, overheating and risk of fire. Use of any other charger or cable voids the manufacturer warranty.
- Do not connect or attach the Maverick or the battery to a power supply plug or directly to a car's cigarette lighter.
- Do not place the Maverick or batteries near a fire, or into direct sunlight. Heating the Maverick and/or the battery can cause additional heating, breaking, or ignition of the battery inside the Maverick.
- Do not continue charging the battery if it does not recharge within the specified charging time. Doing so may cause the battery to become hot, rupture, or ignite.

To preserve natural resources, please recycle or dispose of batteries properly. This product contains lithium-ion batteries. Local, state, or federal laws may prohibit disposal of lithium-ion batteries in ordinary trash. Consult your local waste authority for information regarding available recycling and/or disposal options.

- Do not attempt to modify, change, or replace your battery.

## WARNING

Failure to follow the safety precautions listed below could lead to serious bodily injury and/or death.

- Use only the charger and charging cable supplied by Hover-1. Use of any other charger or cable may lead to damage to the product, overheating and risk of fire. Use of any other charger or cable voids the manufacturer warranty.
- Do not use your Maverick if the battery begins to emit odor, overheats, or begins to leak.
- Do not touch any leaking materials or breathe fumes emitted.
- Do not allow children and animals to touch the battery.
- The battery contains dangerous substances, do not open the battery, or insert anything into the battery.
- Only use the charger provided by Hover-1.
- Do not attempt to charge the Maverick if the battery has discharge or emits any substances. In that case, immediately distance yourself from the battery in case of fire or explosion.
- Lithium-ion batteries are considered to be hazardous materials. Please follow all local, state and federal laws in regards to recycling, handling and disposing of Lithium-ion batteries.

 **WARNING**

SEEK IMMEDIATE MEDICAL ASSISTANCE IF  
YOU ARE EXPOSED TO ANY SUBSTANCE  
THAT IS EMITTED FROM THE BATTERY.

# CARE & MAINTENANCE

- Do not expose the Maverick to liquid, moisture, or humidity to avoid damage to the product's internal circuitry.
- Do not use abrasive cleaning solvents to clean the Maverick.
- Do not expose the Maverick to extremely high or low temperatures as this will shorten the life of the electronic components, destroy the battery, and/or distort certain plastic parts.
- Do not dispose of the Maverick in fire as it may explode or combust.
- Do not expose the Maverick to contact with sharp objects as this will cause scratches and damage.
- Do not allow the Maverick fall from high places, as doing so may damage the internal circuitry.
- Do not attempt to disassemble the Maverick.
- Use only the charger provided by Hover-1.

## **WARNING**

Avoid using water or other liquids for cleaning. If water or other liquids enter the Maverick, it will cause permanent damage to the internal components.

## **WARNING**

Users who disassemble the Maverick scooter without permission will void the warranty.

## WARRANTY

For warranty information, Please visit us at:  
[www.hover-1.eu](http://www.hover-1.eu)

Affix Serial Number Label Here:

## TROUBLESHOOTING

For UK Customer Service, please contact +44 (0) 1355 241222 /  
[escoters@letmerepair.co.uk](mailto:escoters@letmerepair.co.uk)

For other countries, please scan QR code below for more information.



## WEEE DIRECTIVE



Following information is only for EU-member states: The mark shown to the right is in compliance with the Waste Electrical and Electronic Equipment Directive 2012/19/EU (WEEE). The mark indicates the requirement NOT to dispose the equipment as unsorted municipal waste, but use the return and collection systems according to local law.

## EC DECLARATION OF CONFORMITY

[https://drive.google.com/open?id=1T505bsPrZy4N0l-wAc1T4EVEi0blF61\\_](https://drive.google.com/open?id=1T505bsPrZy4N0l-wAc1T4EVEi0blF61_)

# CHARGER LABEL



USE WITH: MAVERICK (EU-HI-MAVE)

SWITCHING POWER SUPPLY

MODEL: FY0184200400B  
INPUT: 100-240 VAC, 50/60Hz,  
0.8A MAX IP20  
OUTPUT: 42V= 0.4A TA=40°C



MADE IN CHINA

Shenzhen Fuyuanlian Power Co.,Ltd

## CAUTION!

RISK OF ELECTRICAL SHOCK.  
PLEASE DO NOT OPEN.  
FOR INDOOR USE ONLY.  
DRY LOCATION USE ONLY.  
DO NOT REMOVE THIS TAG.

# SCOOTER LABELS



Model: EU-HI-MAVE  
Input: 42 V= 0.4 A  
Maximum Weight: 160 lbs / 72.5 kg  
Minimum Weight: 44 lbs / 20 kg  
Maximum Speed: Up to 7 mph / 11.2 km/h  
Weight: 15 lbs / 6.8 kg  
Motor: 200 W  
Battery Capacity: 2.0 Ah  
Battery Type: Rechargeable Lithium-ion battery  
Made in: Shenzhen, Guangdong, China  
Ref: XXXXXXX MFG Date: XXXXX  
PO: XXXXX

Use only with LT1865-NL02 battery.

Manufacturer: DGL Group  
RS House, LE5 ITL, United Kingdom



MADE IN CHINA

This device complies with part 15 of the FCC Rules. Operation is subject to the following two conditions: (1) This device may not cause harmful interference, and (2) this device must accept any interference received, including interference that may cause undesired operation.

**WARNING** - To reduce the risk of injury, user must read instruction manual. Store indoors when not in use.





# WARNING!

**FOR YOUR SAFETY, PLEASE READ THE ENTIRE USER MANUAL BEFORE OPERATING THE HOVER-1 SCOOTER.**

- Always wear proper protective equipment, such as helmets. Helmets should fit properly with the chin strap in place, so that it provides protection for your entire head.
- Accelerate gradually. Never lunge or tilt forward suddenly during operation.
- Avoid obstacles and slippery surfaces that could result in a loss of balance or traction and cause a fall.
- Do not attempt to accelerate when you hear the beep warning for speeding.
- Do not start on rocky, slippery, sandy, gravelly, sloped, or wet surfaces.
- Riders should be at least 8 years old and 5 feet tall.
- Maximum weight load is 160 lbs.
- Adult supervision required.
- Always wear shoes.
- Never use near or around motor vehicles.
- Do not ride at night.
- Do not operate near swimming pools or other bodies of water.

**FAILURE TO FOLLOW THE ABOVE INSTRUCTIONS AND OTHER MISUSE CAN RESULT IN DEATH OR SERIOUS INJURY OR DAMAGE TO THE PRODUCT. USE AT YOUR OWN RISK.**



# WARNING!

**WARNING: Risk of Fire - No User Serviceable Parts**



**WARNING - TO REDUCE RISK OF INJURY, USER MUST READ INSTRUCTION MANUAL  
AVERTISSEMENT-POUR PRÉVENIR LES BLESSURES, L'UTILISATEUR DOIT LIRE LE MANUEL D'UTILISATION.**

- Wear an approved helmet and appropriate safety gear.
- Do not ride vehicle after consuming drugs or alcohol.
- Do not ride without proper training and guidance.
- Do not ride at high speeds, on steep slopes, or in rocky or uneven terrain.
- Do not carry passengers. Do not perform stunts, tricks, or turn sharply.
- Do not leave unattended while charging. Do not charge for more than 7.5 hours. Allow to cool before charging.
- You must comply with all applicable local, state, and federal laws when operating this device.
- Use only the supplied charger with this scooter.
- Use only the supplied battery pack with this scooter. (36V, 2.0Ah)
- Use only with specified manufactured and model charger in instruction.

**Polarity**



HOVER-1 MODEL: EU-HI-MAVE  
CONTROL NUMBER: 5GX3  
42V DC, 0.4A, 32-104° F (0-40° C)

MADE IN CHINA



@RideHover1



@RideHover1



@RideHover1



[www.Hover-1.eu](http://www.Hover-1.eu)