

HOVER-1 NANO

PARTS

1. Handlebars
2. Twist Lock
3. Height Adjustment Button
4. LED Steering Column
5. Foot Brake
6. LED Foot Deck
7. Release Lever
8. Folding Clamp

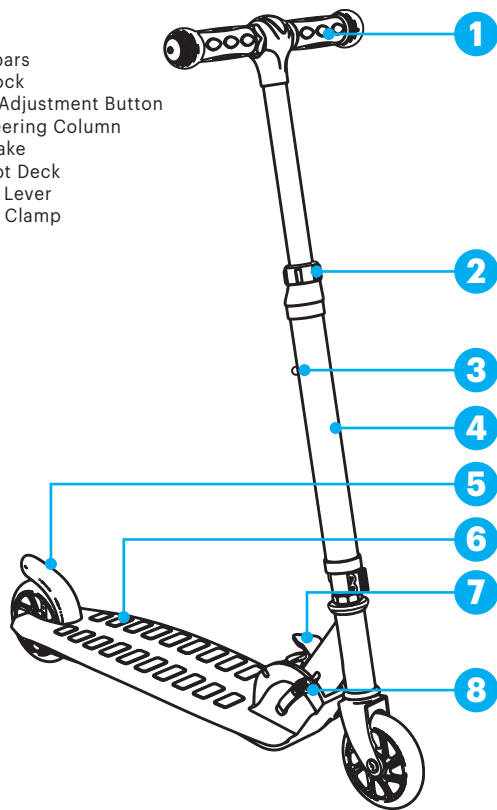

PINCH POINTS

Some parts of your Nano scooter can injure you if mishandled. Moving parts, clamps, and height-adjustable parts can cut or pinch skin. Please watch for pinch points where injury may be sustained. Do not leave your hand, any body parts, or clothing on or near these areas while folding, unfolding, or adjusting the height of your Nano scooter.

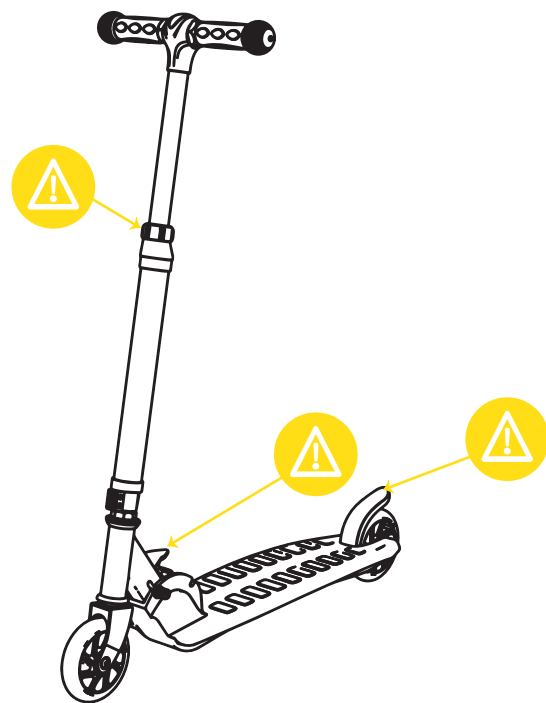

QUICK START GUIDE

HOVER-1 NANO

FOLDING / UNFOLDING

ADULT SUPERVISION REQUIRED

To fold your scooter, open the folding clamp on the side of the scooter, pull the release lever up, and push the handlebars down until you hear a click. To unfold your scooter, open the folding clamp and pull up on the release lever until it clicks. Raise the handlebars up until it clicks again.

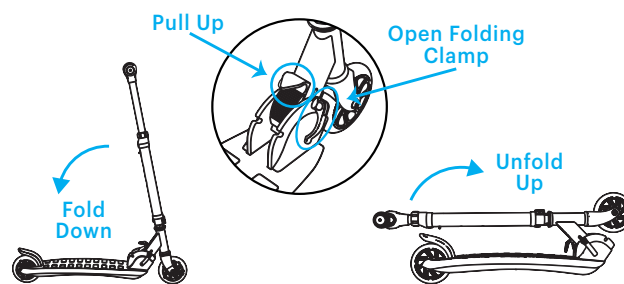

POWER ON/OFF LED LIGHTS

To power on/off the LED lights, locate the switch on the bottom of the scooter and slide it to the on or off position. If the foot deck lights do not turn on, press the button on the bottom of the scooter once. Press the button repeatedly to cycle through different lighting modes for the foot deck. You may turn the deck lights off and keep the steering column lights on by pressing and holding the button.

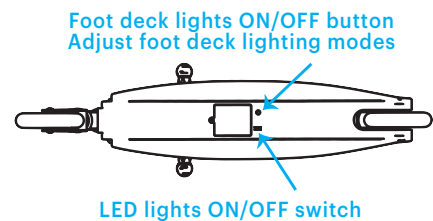

QUICK START GUIDE

HEIGHT ADJUSTMENT

To adjust the height of the handlebars, unscrew the twist lock and push the height adjustment button in. Raise or lower the handlebars to the desired height. Make sure the height adjustment button clicks into place. Screw the twist lock back into place.

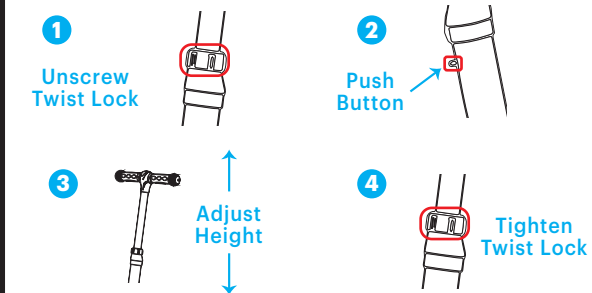

BATTERY REPLACEMENT

ADULT SUPERVISION REQUIRED

To replace the batteries for the LED lights, locate the battery compartment under the scooter. Unscrew the cover with a screwdriver and replace all 3 AA batteries. Replace the cover and screw it back into place.

