

ALPHA PRO



OPERATION MANUAL
H1-ALPRO

HELMETS SAVE LIVES!

Always wear a properly fitted helmet that complies with CPSC or CE safety standards when you ride your E-Scooter.

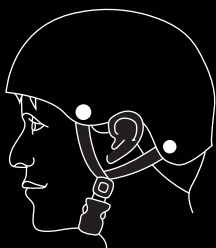

Correct Fit:

Make sure your helmet covers your forehead.

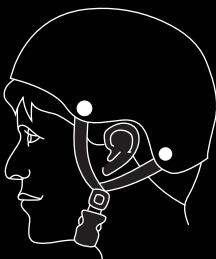

Incorrect Fit:

Forehead is exposed and vulnerable to serious injury.

WARNING

As with all mechanical devices, the Hover-1 Alpha Pro is subject to wear and high stresses. Different materials and components may react to wear or fatigue in different ways. If the design life of a component has been exceeded, it may suddenly fail, possibly causing injuries to the rider. Any form of crack, scratch, or change of coloring in highly stressed areas indicate that the life of the component has been reached and it should be replaced. Do not ride in an abusive manner.

CAUTION

In this manual, the CAUTION sign indicates a hazardous situation which, if not avoided, can cause minor or moderate injury.

WARNING

In this manual, the WARNING sign indicates a hazardous situation which, if not avoided, can cause serious injury or death.

WARNING

Great care should be taken with the Hover-1 Alpha Pro when folding and unfolding it. Moving and folding parts can cut skin or pinch if mishandled.

DO NOT RIDE YOUR HOVER-1 ALPHA PRO WITHOUT THE STEERING COLUMN, FOLDING HINGE, AND HANDLEBARS SECURELY LOCKED IN PLACE.

WARNING

PLEASE READ THE OPERATION MANUAL THOROUGHLY.
Failure to follow the basic instructions and safety precautions listed in the operation manual can lead to damage to your Alpha Pro, property damage, serious bodily injury, and even death.

Thank you for purchasing the Hover-1 Alpha Pro. Please read all instructions carefully before using it and retain this manual for future reference.

- To avoid collisions, falls, and loss of control, please learn how to ride the Alpha Pro safely.
- You can learn how to ride the Alpha Pro by reading the operation manual and watching videos.
- All users are responsible for any consequences caused by violating warning contents or proper operations. Hover-1 can not be held liable.

ATTENTION

1. Use only the supplied charger from Hover-1 with this E-Scooter.
2. The operating temperature range of the charger is 32°F - 104°F (0°C - 40°C).
3. The operating temperature range of the Alpha Pro is 32°F - 104°F (0°C - 40°C).
4. Do not ride on icy or slippery surfaces.
5. Read the operation manual and warning labels before riding.
6. Store the Alpha Pro in a dry, ventilated environment.
7. When transporting the Alpha Pro, avoid violent crashes or impact.

LOW TEMPERATURE WARNING

Low temperatures will affect the lubrication of moving parts inside the Alpha Pro, increasing internal resistance. Additionally, the discharge capacity and capacity of the battery will be significantly decreased.

Use caution when riding the Alpha Pro in cold temperatures (below 40°F/4°C). Doing so may increase the risk of mechanical failures of the E-Scooter, which may lead to damage to your device, property damage, serious bodily injury, and even death.

SAFETY INSTRUCTIONS

- Keep the E-Scooter away from heat sources, direct sunlight, humidity, water, and any other liquids.
- Do not operate the E-Scooter if it has been exposed to water, moisture, or any other liquids to prevent electric shock, explosion, and/or injury to yourself and damage to the E-Scooter.
- Do not use the E-Scooter if it has been dropped or damaged in any way.
- Repairs to electrical equipment should only be performed by the manufacturer. Improper repairs void the warranty and may place the user at serious risk.
- Do not puncture or harm the exterior surface of the E-Scooter in any way.
- Keep the device free from dust, lint, etc.
- Do not use this E-Scooter for anything other than its intended use or purpose. Doing so may damage the E-Scooter or lead to property damage, injury, or death.
- This product is not a toy. Keep out of reach of children.
- Do not expose the batteries to excessive heat such as direct sunlight or an open flame.
- Do not allow hands, feet, hair, body parts, clothing, or similar articles to come in contact with moving parts, wheels, or the drivetrain while the Alpha Pro is running.

- Do not operate or allow others to operate the Alpha Pro until the user understands all instructions, warnings, and safety features described in this manual.
- Check with your doctor if you have a medical condition that could affect your ability to use the Alpha Pro.
- Persons with head, back, neck ailments, or prior surgeries to those areas of the body are not recommended to use the Alpha Pro.
- Do not operate if you are pregnant or have a heart condition.
- Persons with any mental or physical conditions that may make them susceptible to injury or impair their physical or mental capabilities to recognize, understand, and perform all of the safety instructions and assume the hazards inherent in operation should not use the Alpha Pro.

SERIAL NUMBER

Please keep your serial number on file for warranty claims as well as proof of purchase.

WARNING

Prolonged exposure to UV rays, rain, and the elements may damage the enclosure materials. Store indoors when not in use.

INTRODUCTION

The Alpha Pro is a personal transporter. Our production processes are developed with strict testing for each Alpha Pro E-Scooter. Operating the Alpha Pro without following the contents of this manual may lead to damage to your Alpha Pro E-Scooter or bodily injury.

PACKAGE CONTENTS

- Hover-1 Alpha Pro Electric Folding Scooter
- Charger & Charging Cable
- Hex Key and Bolts
- Air Pump

Your Alpha Pro's serial number is stamped on the bottom of the E-Scooter platform. Record the serial number in the designated area of the "WARRANTY" section of this manual in case your Alpha Pro is lost or stolen.

SAFETY PRECAUTIONS

- The first rule of safe riding is to use common sense.
- Different localities and countries have different laws about riding electric transportation devices on public roads. You should check with local officials to ensure you are complying with local traffic law requirements.
- Hover-1 is not liable for tickets or violations given to riders who do not follow local laws and regulations.
- For your safety, always wear a helmet that meets CPSC or CE safety standards. In the event of an accident, a helmet can protect you from serious injury and in some cases, even death.

- Obey all local traffic laws. Obey red and green lights, one-way streets, stop signs, pedestrian crosswalks, etc.
- Ride with traffic, not against it.
- Ride defensively; expect the unexpected.
- Give pedestrians the right-of-way.
- Do not ride too close to pedestrians and alert them if you intend to pass them from behind.
- Slow down at all street intersections and look to the left and right before crossing.
- Your Alpha Pro electric folding scooter is not equipped with reflectors. It is not recommended that you ride in conditions of low visibility.
- If you are riding your E-Scooter in low-visibility conditions, ensure your LED headlight is turned on, and that you are wearing bright, reflective clothing.



WARNING

When you ride in low-visibility conditions such as fog, dusk, or night, you might be difficult to see, which could lead to a collision. To increase your level of safety, be sure to wear bright, reflective clothing when riding in low-visibility conditions.

- Do not ride above your skill level. Ensure you have had enough practice with all functions and features of your Alpha Pro.
- Do not ride too fast – with increased speed comes increased risk. If you are moving at a higher speed, small bumps can create strong impacts, leading to a higher risk of injury.
- Do not ride with pets.
- Before stepping on your Alpha Pro, make sure it is placed flat on level ground.

- Do not try to open or modify your Alpha Pro E-Scooter. Doing so voids the manufacturer warranty and may cause your Alpha Pro to fail, resulting in injury or death.
- Do not use the Alpha Pro in a manner that would put people or property in danger.
- If you are riding near other riders, be sure to maintain a safe distance between each other to prevent collisions.
- Be sure to keep your feet on the Alpha Pro at all times. Moving your feet off your Alpha Pro while driving is dangerous and may cause the Alpha Pro to stop suddenly or veer sideways.
- Do not operate the Alpha Pro while under the influence of drugs or alcohol.
- Do not operate the Alpha Pro when you are restless or sleepy.
- Use your best judgment to keep yourself out of dangerous situations with your Alpha Pro.
- Do not ride your Alpha Pro off of curbs, ramps, or attempt to operate in a skate park, empty pool, or in any way similar to a skateboard. Misuse of your Alpha Pro voids the manufacturer warranty and may lead to injury or damage.
- Do not abuse your Alpha Pro. Doing so can damage your unit and cause failure to the operating system, which may lead to injury. Physical abuse, including dropping your Alpha Pro, voids the manufacturer warranty.
- Do not operate in or near puddles of water, mud, sand, stones, gravel, debris, or near rough and rugged terrain.
- The Alpha Pro can be used on paved surfaces that are flat and even. If you encounter uneven pavement, lift your Alpha Pro over and past the obstruction.
- Do not ride in inclement weather: snow, rain, hail, sleet, on icy roads, or in extreme heat or cold.
- Bend your knees when riding on bumpy pavement to absorb the shock and vibrations. This will help you keep your balance.
- If you are unsure if you can safely ride on a specific terrain, step off

WARNING

Proper use of your brake is vital to ensure safe, efficient stopping. To avoid misuse and potential injury, do not apply sudden or excessive force to your brakes. Apply your brakes gradually and give yourself enough room to come to a complete stop safely.

and carry your Alpha Pro. Always be on the side of caution.

- Do not attempt to ride over bumps or objects greater than ½ inch, even when prepared and bending your knees.
- Pay attention. Look where you are riding and be conscious of the road conditions, people, property, and objects around you.
- Do not operate the Alpha Pro in crowded areas.
- Operate your Alpha Pro with extreme caution when indoors, especially around people, property, and narrow spaces.
- Do not operate the Alpha Pro while talking, texting, or looking at your phone.
- Do not ride your Alpha Pro where it is not permitted.
- Do not ride your Alpha Pro near motor vehicles or on public roads.
- Do not travel up or down steep hills.
- The Alpha Pro is intended for use by a single individual, DO NOT attempt to operate the Alpha Pro with two or more people.
- Do not carry anything while riding the Alpha Pro.
- Individuals with lack of balance should not attempt to operate the Alpha Pro.
- Young children and the elderly should not operate the Alpha Pro.
- At higher speeds, always take longer stopping distances into consideration.
- Do not attempt to jump on or off your Alpha Pro.
- Do not attempt any stunts or tricks with your Alpha Pro.

- Do not ride the Alpha Pro in dark or poorly lit areas.
- Do not ride the Alpha Pro near or over potholes, cracks, or uneven pavement or surfaces.
- Do not operate your Alpha Pro off-road.
- Do not turn sharply, especially at high speeds.
- Do not exceed the maximum weight limit of 264 lbs (120 kg).
- Avoid driving the Alpha Pro in unsafe places, including areas with flammable gas, steam, liquid, dust, or fiber that could cause fire and explosion accidents.
- Do not operate near swimming pools or other bodies of water.
- Maintain a safe braking distance during wet conditions.

WARNING

There may be additional risk of injury if you use your E-Scooter incorrectly. This includes, but is not limited to:

- Jumping your E-Scooter
- Riding over debris or obstacles
- Performing stunts
- Riding off-road
- Riding fast
- Racing other riders
- Riding in an unusual manner

The aforementioned examples add stress to each part of your E-Scooter and can lead to long term damage of the device. Damage to your E-Scooter can lead to an accident or increase your risk of injury. To decrease your risk of injury, use your E-Scooter correctly.

WARNING

To reduce the risk of injury, adult supervision is required. Never use in roadways, near motor vehicles, on or near steep inclines or steps, swimming pools, or other bodies of water. Always wear shoes, and never allow more than one rider at a time.

CARE & MAINTENANCE

- To avoid damage to the Alpha Pro's internal circuitry, do not expose it to liquid, moisture, or humidity.
- Do not use abrasive cleaning solvents to clean the Alpha Pro.
- Do not expose the Alpha Pro to extremely high or low temperatures, as this will shorten the life of the device, destroy the battery, and/or distort certain plastic parts.
- Do not dispose of the Alpha Pro in fire as it may explode or combust.
- Do not let the Alpha Pro come into contact with sharp objects, as this will cause scratches and damage.
- Do not let the Alpha Pro fall from high places, as doing so may damage the internal circuitry.
- Do not attempt to disassemble the Alpha Pro.
- Use only the charger provided by Hover-1.
- Use only the manufacturer's authorized replacement parts.

WARNING

Avoid using water or other liquids for cleaning. If water or other liquids enter the Alpha Pro, it will cause permanent damage to the internal components.

WARNING

Users who disassemble the Alpha Pro without permission from Hover-1 will void the warranty.

BATTERY CARE / MAINTENANCE

BATTERY SPECIFICATIONS

Battery Type: Rechargeable lithium-ion battery

Charge Time: Up to 5 hours

Battery Voltage: 36V

Battery Capacity: 8.25Ah

Working Temperature: 32°F - 104°F (0°C - 40°C)

Charging Temperature: 32°F - 104°F (0°C - 40°C)

Storage Time: 1 year

Storage Temperature: 32°F - 104°F (0°C - 40°C)

Storage Humidity: 5% - 95%

BATTERY MAINTENANCE

- The lithium-ion battery is built into the E-Scooter. Do not disassemble the E-Scooter to remove the battery or attempt to separate it from the E-Scooter.
- When charging the E-Scooter, only use the enclosed 1-pin charging cable provided by Hover-1. Use of any other charger or cable may lead to damage to the E-Scooter, overheating, and risk of fire. Use of any other charger or cable voids the manufacturer warranty.
- Do not connect or attach the E-Scooter or the battery to a power supply plug or directly to a car's cigarette lighter.
- Do not place the E-Scooter near a fire or leave it out in direct sunlight. Heating the E-Scooter can break or ignite the battery inside the device.
- Do not continue charging the battery if it does not recharge within the specified charging time. Doing so may cause the battery to become hot, rupture, or ignite.
- To preserve natural resources, please recycle or dispose of batteries properly. This product contains lithium-ion batteries. Local, state, or federal laws may prohibit disposal of lithium-ion batteries in ordinary trash. Consult your local waste authority for information regarding available recycling and/or disposal options.

WARNING

Failure to follow the safety precautions listed below could lead to serious bodily injury or death.

- Do not attempt to modify, change, or replace your battery.
- Do not use your device if the battery begins to emit odor, overheats, or begins to leak.
- Do not touch any leaking materials or breathe fumes emitted.
- Do not allow children or animals to touch the battery.
- The battery contains dangerous substances. Do not open the battery or insert anything into the battery.
- Do not attempt to charge the device if the battery has discharge or emits any substances. In that case, immediately distance yourself from the battery in case of fire or explosion.

 **WARNING**

SEEK IMMEDIATE MEDICAL ASSISTANCE IF
YOU ARE EXPOSED TO ANY SUBSTANCE
THAT IS EMITTED FROM THE BATTERY.

SPECIFICATIONS

Model:	H1-ALPRO
Net Weight:	34.4 lbs (15.6 kg)
Max Supported Weight:	264 lbs (120 kg)
Min Supported Weight:	44 lbs (20 kg)
Max Speed:	Up to 18 mph (28.9 km/h)
Max Range:	Up to 18 miles (28.9 km)
Battery Type:	Lithium-ion
Motor Power:	450W brushless motor
Battery Voltage:	36V
Battery Capacity:	8.25Ah (30 cell)
Power Requirement:	100V-240V, 50 Hz/60 Hz
Folding Size:	45.0 in. x 16.9 in. x 20.7 in. (114.3 cm x 43.0 cm x 52.8 cm)
Open Size:	45.0 in. x 16.9 in. x 47.7 in. (114.3 cm x 43.0 cm x 121.3 cm)
Tire Type:	Inflated rubber tires
Tire Size:	10" front & rear
Tire Inflation Pressure:	340 kPa
Brake Type:	Handle-activated rear disc brake
BT ID:	D042258
FCC ID:	2AANZALPHA20G
UL Certification:	UL2272 certified

PARTS LIST

- A.** Alpha Pro E-Scooter
- B.** Handlebar Assembly
- C.** Charger + Charging Cable
- D.** Hex Key & Bolts
- E.** Air Pump
- F.** 6 Spare Bolts

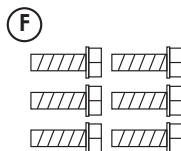
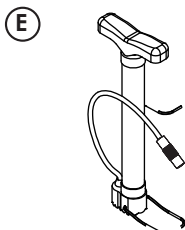
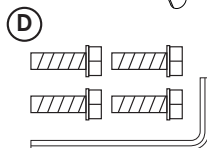
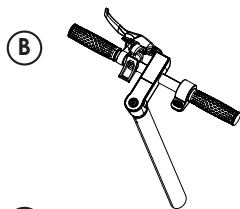
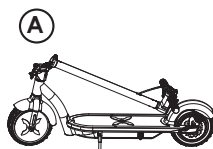

HOVER-1 ALPHA PRO DIAGRAM

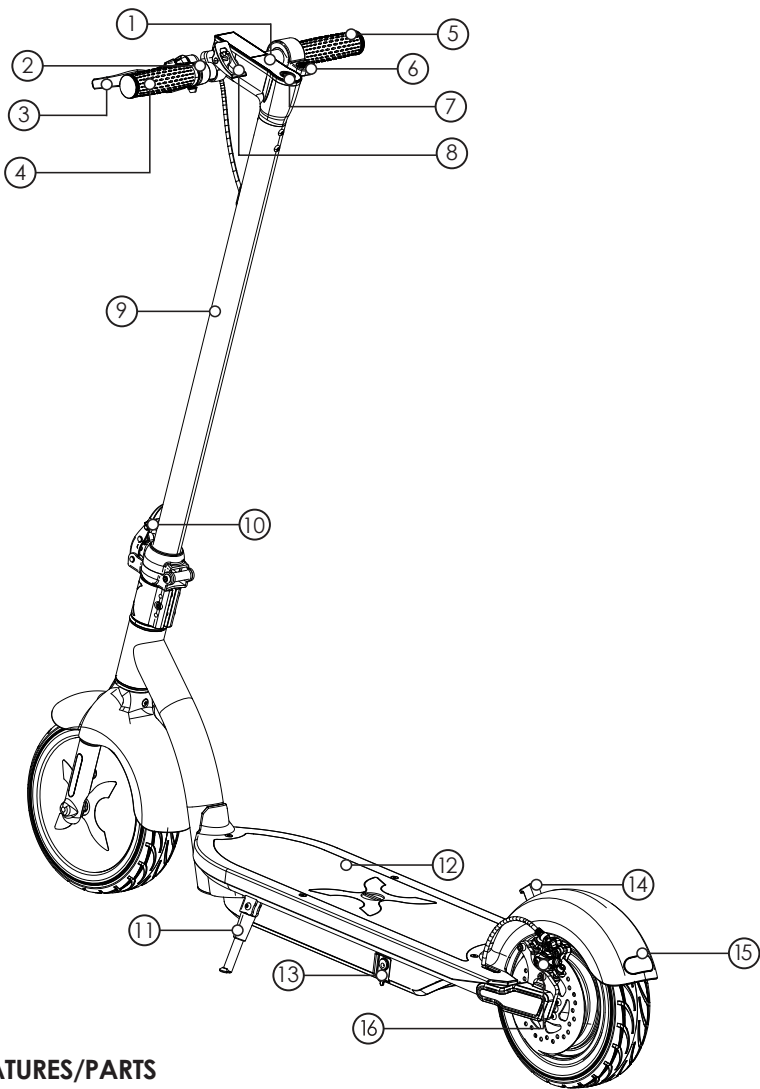

FEATURES/PARTS

- | | |
|------------------|---------------------|
| 1. LED Display | 9. Steering Column |
| 2. Bell | 10. Folding Hinge |
| 3. Brake Handle | 11. Kickstand |
| 4. Handlebar (L) | 12. Foot deck |
| 5. Handlebar (R) | 13. Charging Port |
| 6. Throttle | 14. Folding Hook |
| 7. Power Button | 15. Brake Light |
| 8. Folding Clip | 16. Rear Disc Brake |

HOVER-1 ALPHA PRO DIAGRAM

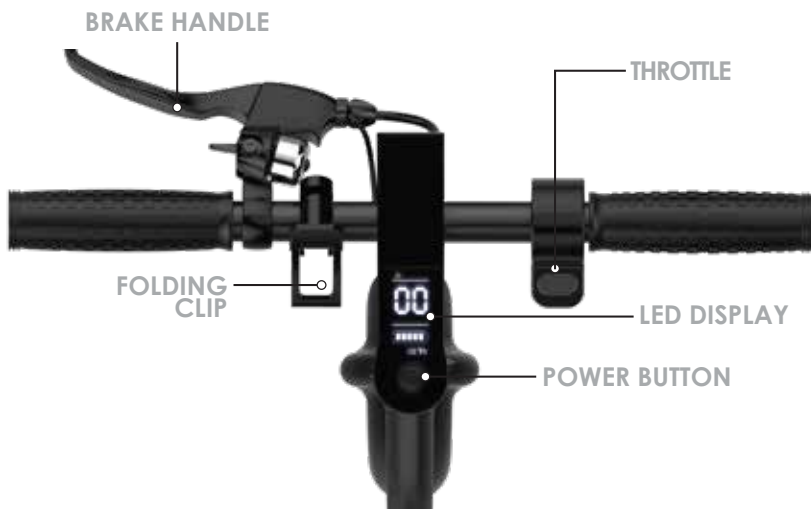

LED DISPLAY

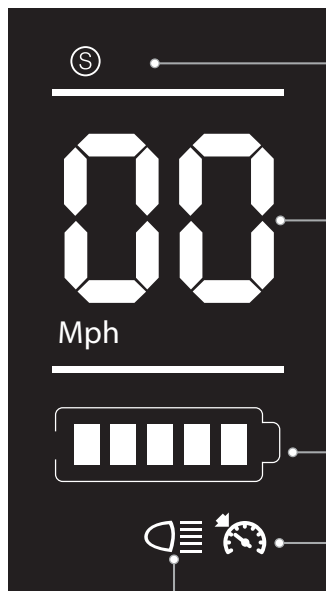

HIGH SPEED MODE

The 'S' icon indicates high speed mode is activated. When the E-Scooter is powered on, press the power button once to switch between high and low speed mode.

SPEEDOMETER

Displays your current speed in Mph.

Displays the current speed mode when toggled:

- 1 - Low speed mode (max speed 12 mph)
- 2 - High speed mode (max speed 18 mph)

BATTERY INDICATOR

Displays your current battery level.

CRUISE CONTROL ICON

Indicates cruise control is activated. While riding at a constant speed above 3 mph, press the throttle down two times quickly. You will hear a beep and the cruise control indicator will light up on the LED display, indicating that it is activated. Press the throttle down once or squeeze the brake handle to cancel cruise control.

HEADLIGHT ICON

Indicates the headlight is activated. Quickly press the power button two times to turn the headlight on/off.

BLUETOOTH® SPEAKER

The Alpha Pro has a powerful built-in wireless speaker, so you can play your music while riding.

PAIRING THE SPEAKER

- 1) Turn on your E-Scooter. The speaker will “ping” to announce that it’s waiting for a Bluetooth® connection. This will indicate your E-Scooter’s speaker is now in pairing mode.
- 2) Place the E-Scooter and the Bluetooth® device you would like to pair within the operating distance. We recommend keeping the two devices no further than 3 feet (1 meter) apart during pairing.
- 3) Ensure Bluetooth® is enabled on your phone or music device. Refer to the manufacturer’s instructions for how to enable Bluetooth® on your device.
- 4) Once you have activated Bluetooth® on your device, select the option “H1-ALPRO” from the list of available Bluetooth® devices.
- 5) If prompted, enter the PIN code “000000” and confirm the entry.
- 6) The speaker will say “paired” when successfully paired.
- 7) Please note, pairing mode on the E-Scooter will last for two minutes. If no devices are paired after two minutes, the E-Scooter speaker will automatically return to standby mode.
- 8) If pairing is unsuccessful, turn off the E-Scooter first and try again following the previous steps.
- 9) If your smartphone is out of range, or the battery is low on your E-Scooter, the speaker may disconnect from your device, and the speaker will say “disconnected.” To reconnect, follow the previous steps, or recharge your E-Scooter.

NOTE: Once you have paired the E-Scooter speaker with a device, the speaker will remember the device and will pair automatically when the device’s Bluetooth® is activated within range. You do not need to re-pair any previously connected devices.

Your E-Scooter can pair with up to two multi-point devices at a time. You can reconnect a previously paired device without going through the pairing process for up to two devices.

LISTENING TO MUSIC

Once the Bluetooth® speaker is paired to your device, you can stream music wirelessly through it. Select the track you wish to listen to on your device. All volume and track controls will be made using your music device. Should you encounter any problems while streaming, please refer to your device’s user manual.

CHARGING YOUR ALPHA PRO

- Ensure that the charging port is clean and dry.
- Make sure that there is no dust, debris, or dirt inside the port.
- Plug the charger into a grounded wall outlet.
- Connect the cable with the power supply (100V-240V; 50 Hz/60 Hz).
- Align and connect the 1-pin charging cable into the charging port of the Alpha Pro (DO NOT FORCE OR BEND THE CHARGING CABLE AS IT MAY CAUSE THE PRONGS TO BEND OR BREAK).
- The charging indicator light on the charger itself should change to red, indicating that your E-Scooter is now being charged.
- When the red indicator light on your charger changes to green, your E-Scooter is fully charged.
- After fully charging your E-Scooter, unplug the charger from your device and from the wall outlet.
- If the E-Scooter is not used for an extended period of time, you may need to recharge the battery every 2 months to maintain the battery life.

CAUTION

Only use the included charging cable and charger to charge your Alpha Pro. Using any other charger may damage your Alpha Pro.

PREPARING YOUR E-SCOOTER

PLEASE READ THE FOLLOWING INSTRUCTIONS CAREFULLY

ATTACHING THE HANDLEBAR ASSEMBLY

Attach the handlebar assembly by placing it into the steering column, aligning the front and back bolt holes, and tightening the 4 bolts into place with the hex key.



PINCH POINTS

Some parts of your Alpha Pro can injure you if mishandled. Moving and folding parts can cut skin. Clamps and pivoting parts such as brake levers can pinch. When folding and unfolding your Alpha Pro, please watch for pinch points where injury may be sustained. Do not leave your hand in these areas during the folding or unfolding process.



LOCKING MECHANISM

After riding the E-Scooter, the locking mechanism may loosen over time. If you notice the steering column is loose, don't ride the E-Scooter until it is fully secured. Use the hex key provided to tighten point "A" (marked below) until the locking mechanism fits securely. If you are unable to close the mechanism completely, you may need to loosen point "A" slightly until the locking mechanism is able to close securely.

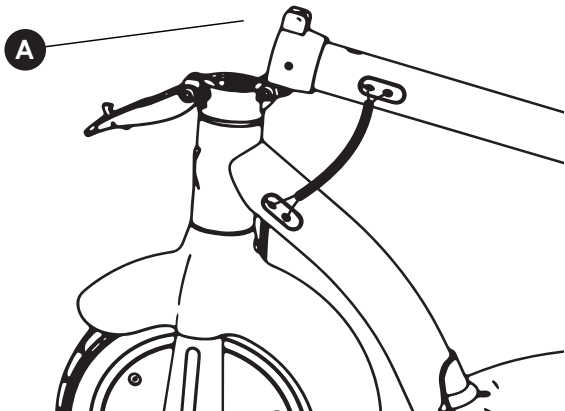

FOLDING & UNFOLDING

To fold your Alpha Pro, push the folding hinge release button and pull the folding hinge down. Lift the steering column safety lock up and push the steering column down to the rear fender. Find the magnetic folding clip on the left handlebar and align the opening with the magnetic tab protruding from the rear fender to lock them together. Your Alpha Pro should be locked in a folded position.

To unfold your Alpha Pro, pull on the bottom edge of the magnetic clip to unlock the steering column. Raise the steering column until it is pointing straight up and clicks into place. Pull the folding hinge up and press it against the steering column to ensure it is securely locked.



RELEASE FOLDING HINGE
TO FOLD STEERING COLUMN

SPEED MODES

To change speed modes, press the power button once while the Alpha Pro is powered on and not in motion. The following are the top speeds for each speed mode:

- 1 - Low speed mode (max speed 12 mph)
- 2 - High speed mode (max speed 18 mph)

CRUISE CONTROL

To activate cruise control, quickly press the throttle down two times while riding at a constant speed above 3 mph. You will hear a beep and the cruise control indicator will light up on the LED display, indicating that it is activated. Press the throttle down once or squeeze the brake handle to cancel cruise control.

KICK TO START

For safety reasons, the Alpha Pro will not accelerate unless it is already moving at least 1.8 mph (3 km/h). You must push off the ground with your foot to get the Alpha Pro moving, then press the throttle to ride it.

BEFORE RIDING

Before each use, the E-Scooter operator shall perform the pre-operation checks as specified below:

- The area that the unit is to be operated in is safe and suitable for safe operation.
- The braking system is functioning properly.
- All safety labels are in place and understood by the operator.
- Any and all axle guards, chain guards, or other covers and guards supplied by the manufacturer are in place and in serviceable condition.
- The tires are in good condition, inflated properly, and have sufficient tread remaining.



WARNING

Any E-Scooter that does not work properly can cause you to lose control and fall. Do not ride an E-Scooter with a part that is damaged. Replace the damaged part before riding.

It is important that you fully understand all elements of your Alpha Pro E-Scooter. If these elements are not used correctly, you will not have full control of your Alpha Pro. Before you ride, learn the functions of the various mechanisms on your Alpha Pro.

Practice using these elements of your Alpha Pro at slower speeds in a flat, open area before taking it out into public areas.

PRE-RIDE CHECKLIST

Ensure that your Alpha Pro is in proper working order each time you ride. If a part of the Alpha Pro does not function correctly, please contact our Customer Support Center.

- Ensure the battery is fully charged before riding your E-Scooter.
- Please wear all appropriate safety and protective gear before operating your E-Scooter.
- Make sure to wear comfortable clothes and flat, closed-toe shoes when operating your E-Scooter.

RIDING YOUR ALPHA PRO

FAILURE TO FOLLOW ANY OF THE FOLLOWING SAFETY PRECAUTIONS MAY LEAD TO DAMAGE TO YOUR DEVICE, DAMAGE TO PROPERTY, VOID YOUR MANUFACTURER WARRANTY, AND MAY CAUSE SERIOUS BODILY INJURY OR DEATH.

OPERATING YOUR DEVICE

Make sure the device is fully charged before the first use. Before turning on your Alpha Pro E-Scooter, ride it like a normal kick scooter to get comfortable with the device before using it with the motor.

When you are comfortable riding the E-Scooter, power it on. For the motor to activate, you must first push off the ground with your foot to get the E-Scooter moving, then press the throttle down with your thumb.

To slow down, disengage the throttle and squeeze the brake handle to engage the disc brake. The brake is pressure-sensitive, so a tighter squeeze will result in more stopping power. Do not attempt to stop suddenly as this may lead to injury or damage to your brake discs.

Use the handlebars to turn the Alpha Pro in the desired direction.

The Alpha Pro can be operated manually if you do not wish to use the motor.

As you get comfortable on the E-Scooter, you will notice it becomes easier to maneuver. Remember at higher speeds, it is necessary to shift your weight when making turns to maintain your stability.

Prepare to brace yourself if you encounter bumps or uneven surfaces. If necessary, dismount your Alpha Pro and carry it to a safe operating surface.

WARNING

Do not turn sharply or at high speeds. Do not turn or ride quickly along slopes, as it may cause injury.

SPEED AND WEIGHT LIMITATIONS

Speed and weight limits are set for your own safety. Please abide by the limits listed here in the manual.

- Maximum Speed: 18 mph
- Maximum Supported Weight: 264 lbs
- Minimum Supported Weight: 44 lbs

WARNING

Riding the Alpha Pro while exceeding the weight limit may increase the possibility of injury or product damage.

OPERATING RANGE

The Alpha Pro can travel up to 12 miles on a fully charged battery under ideal riding conditions. The following are some of the major factors that will affect the operating range of your device:

- Terrain: Operating range is highest when riding on a smooth, flat surface. Riding uphill and/or on rough terrain will reduce the operating range significantly.
- Weight: A lighter user will have a higher operating range than a heavier user.
- Ambient Temperature: Please ride and store the E-Scooter in recommended temperatures. This will increase operating range, battery life, and overall performance of your device.
- Speed and Riding Style: Maintaining a moderate and consistent speed while riding produces maximum operating range. Traveling at high speeds for extended periods of time, frequent starts and stops, and idling will decrease operating range.

WARNING

Proper use of your brake is vital to ensure safe, efficient stopping. To avoid misuse and potential injury, do not apply sudden or excessive force to your brake. Apply the brake gradually and give yourself enough room to come to a complete stop safely.

SAFETY ALERTS

If a system error occurs or an improper operation is performed while riding your Alpha Pro, the device will alert the user in a variety of ways.

The following are common occurrences that will produce safety alerts. These notices should not be ignored and appropriate action should be taken to correct any improper operation, failure, or errors.

- Prohibited riding surfaces (uneven, too steep, unsafe, etc.)
- Battery voltage is too low.
- The E-Scooter is still charging.
- The E-Scooter is overheating, or the motor temperature is too high.
- When the battery is about to run out of power, the battery icon will flash.
- If any or both tires are blocked, the device will stop after 10 seconds.
- When the battery level has depleted below protection mode, the motor will power off after 15 seconds.
- If a high discharge current is produced during use (such as riding up a steep slope for a long period of time), the motor will shut off after 15 seconds.

FCC STATEMENT

NOTE: This equipment has been tested and found to comply with the limits for a Class B digital device, pursuant to Part 15 of the FCC Rules. These limits are designed to provide reasonable protection against harmful interference in a residential installation. This equipment generates, uses, and can radiate radio frequency energy and, if not installed and used in accordance with the instructions, may cause harmful interference to radio communications. However, there is no guarantee that interference will not occur in a particular installation. If this equipment does cause harmful interference to radio or television reception, which can be determined by turning the equipment off and on, the user is encouraged to try to correct the interference by one or more of the following measures:

- Reorient or relocate the receiving antenna.
- Increase the separation between the equipment and receiver.
- Connect the equipment into an outlet on a circuit different from that to which the receiver is connected.
- Consult the dealer or an experienced radio/TV technician for help.

Changes or modifications not expressly approved by the party responsible for compliance could void the user's authority to operate the equipment.

This device complies with Part 15 of the FCC Rules. Operation is subject to the following two conditions:

(1) This device may not cause harmful interference, and (2) this device must accept any interference received, including interference that may cause undesired operation.

WARRANTY

For warranty information, please visit us at www.hover-1.com

Error codes	Error E1 - motor hall failure, the motor needs to be replaced
	Error E2 - accelerator failure, the accelerator needs to be replaced
	Error code E3 - motor blocking fault, release the accelerator
	Error E4/MOS - mainboard MOS tube failure, the mainboard needs to be replaced
	Error E6 - controller / instrument communication failure, the controller needs to be replaced
	Error E7 - battery over-voltage protection, the battery needs to be replaced
	Error E8 - controller error, the controller needs to be replaced
	Error E9 - brake failure, the brake needs to be replaced

Manufacturer: DGL Group, Ltd.
2045 Lincoln Highway, Edison, NJ 08817

TEL: 732-692-5000

Affix Serial Number Label Here:



@Hover1Rideables



@RideHover1



@RideHover1



www.Hover-1.com