

SP-6307



Intel® Atom™ Processor N2800/D2550 Fanless and Low Power 17" Panel PC



Features

- Intel® Atom™ processor N2800/D2550 on board
- Fanless and quiet design
- 1 x CFAST slot
- Optional Wireless LAN module
- Support wide voltage DC in (9~36V)
- Aluminum front bezel



I/O Panel View

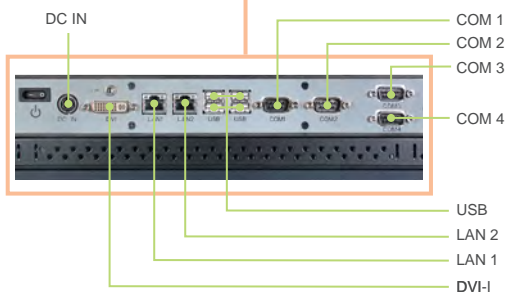
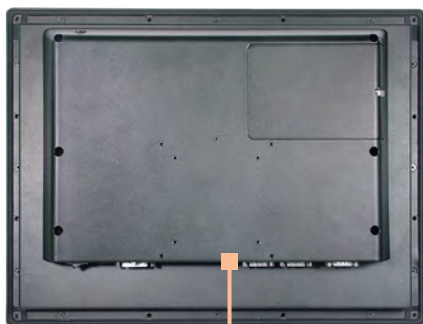

Bird View



Specifications

System

CPU Type	Intel® Atom™ processor N2800/D2550
Chipset	Intel® NM10
Memory Support	1x DDR3 SO-DIMM socket up to 1067 MHz, up to 4GB
Front Bezel	Aluminum
IP65	Yes (for front panel only)
Power	DC in 9~36V
Operating System	Windows7 (32bit)
Dimension (W x H x D)	448 x 353 x 85 mm
System Weight	7.53 Kg
VESA Mounting Support	VESA 75/100
Certificate	FCC / CE

I/O Ports

Display	1 x DVI-I
USB	4 x USB 2.0
Audio	1 x Line-out
LAN	2 x LAN (10/100/1000 Mbps)
Serial Port	4 x COM port, (COM 1/2/3 with 5V/12V) COM 1/4 for RS232 COM 2/3 for RS232/422/485
Drive Bay	1 x 2.5" SATAII HDD
Expansion Slots	1 x CFAST slot, 1 x mini PCIe slot

Display

LCD	17" 1280 x 1024 SXGA 350nit LED backlight LCD
Touch Screen	ELO 5-wire resistive type (USB interface)

Environment

Operation Temp. (with Airflow)	0° ~ 45° C (32° ~ 113° F) (w/HDD) 0° ~ 55° C (32° ~ 131° F) (w/CFAST card)
Storage Temp.	- 20° ~ -60°C (- 4° ~ 140°F)
Humidity	20% ~ 90%

*All information contained in this document is subject to change without prior notice. Please log on www.protech.com.tw to acquire latest information.

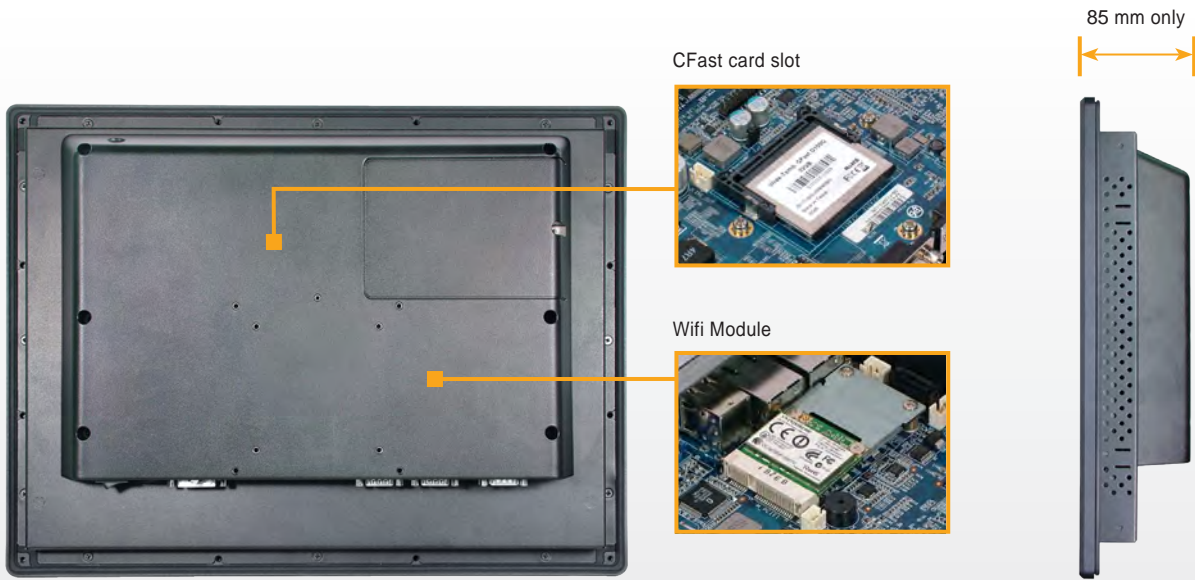

Ordering Information

Order No	Description
SP-6307RA-A0B	17" fanless Intel® Atom™ N2800 Panel PC, with 17" 1280 x 1024 LCD / 5-Wire ELO touch
SP-6307RA-B0B	17" fanless Intel® Atom™ D2550 Panel PC, with 17" 1280 x 1024 LCD / 5-Wire ELO touch

Ordering Accessories

Order No	Description
52-002-11072302	72W DC 24V power adaptor(DIN-4P)(w/Lock)
SE-8210RZ-WL3	Wi-Fi Kit (0°C ~70°C)
52-901-01002210	Wall Mount Kit (VESA 75/100)
52-901-01002213	Wall Mounting VESA Bracket stand
PA-6053RZ-A1B	stand
52-901-00002110	LCD ARM

Dimensions

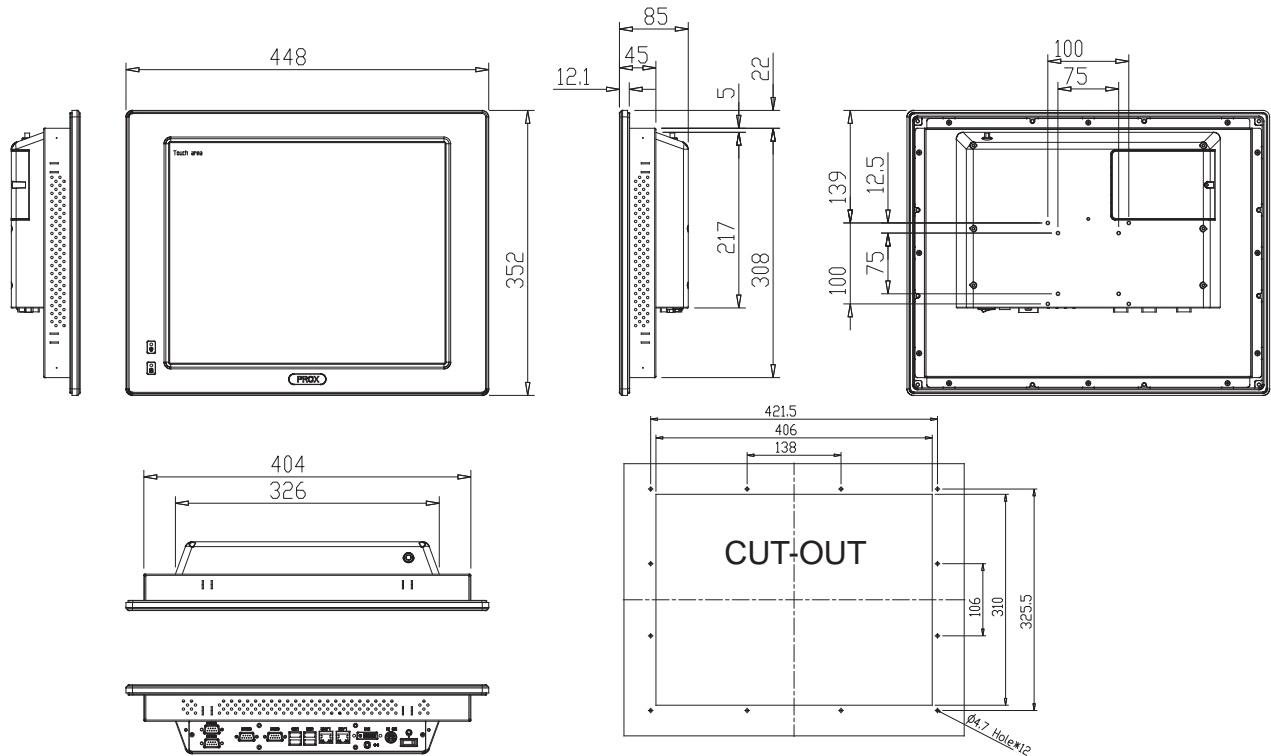

Unit: mm