



Imbue Lighting

imbuelighting.co.uk

We invite you to take a look through this brochure we have created to showcase our interior lighting, which is handmade to the highest quality on the Isle of Anglesey.

Our company was established in 2008 and over the years we have expanded our lighting range to provide UK made lighting which has the wow factor!

We pride ourselves in sourcing unique papers from around the world to create stunning shades to match or compliment your décor. Our current papers include handmade Lokta paper from Kathmandu, Nepal. This very special paper is made in the traditional way using frames and sunshine! Once handmade the lokta paper has many different techniques applied such as Batik, Screen Printing, Resistance or plain Dyeing.

We have recently sourced a range of stunning Yuzen Washi from Kyoto in Japan – Screen printed to the highest quality, which has proven to be consistently popular with many customers.

Our embroidered non woven fabric is a firm favourite and is sourced from Mumbai in India – take a look on Page 52. In addition we make interior lighting using Original Maps as seen on Page 27. We also undertake bespoke commissions using fabrics, wallpapers and posters etc!

We believe that selling via a brochure or website should never diminish the excellent customer service which every single customer deserves. With this in mind, please be assured you will be treated as an individual, and every order will be put together with the utmost care and attention to detail just for you.

Thank you for taking the time to browse through this brochure and we do hope that you feel inspired!

The Imbue Lighting Team - Andy, Mandy and Mark Beal and Ceri Williams

Telephone: 01248 422612

Email: info@imbuelighting.co.uk

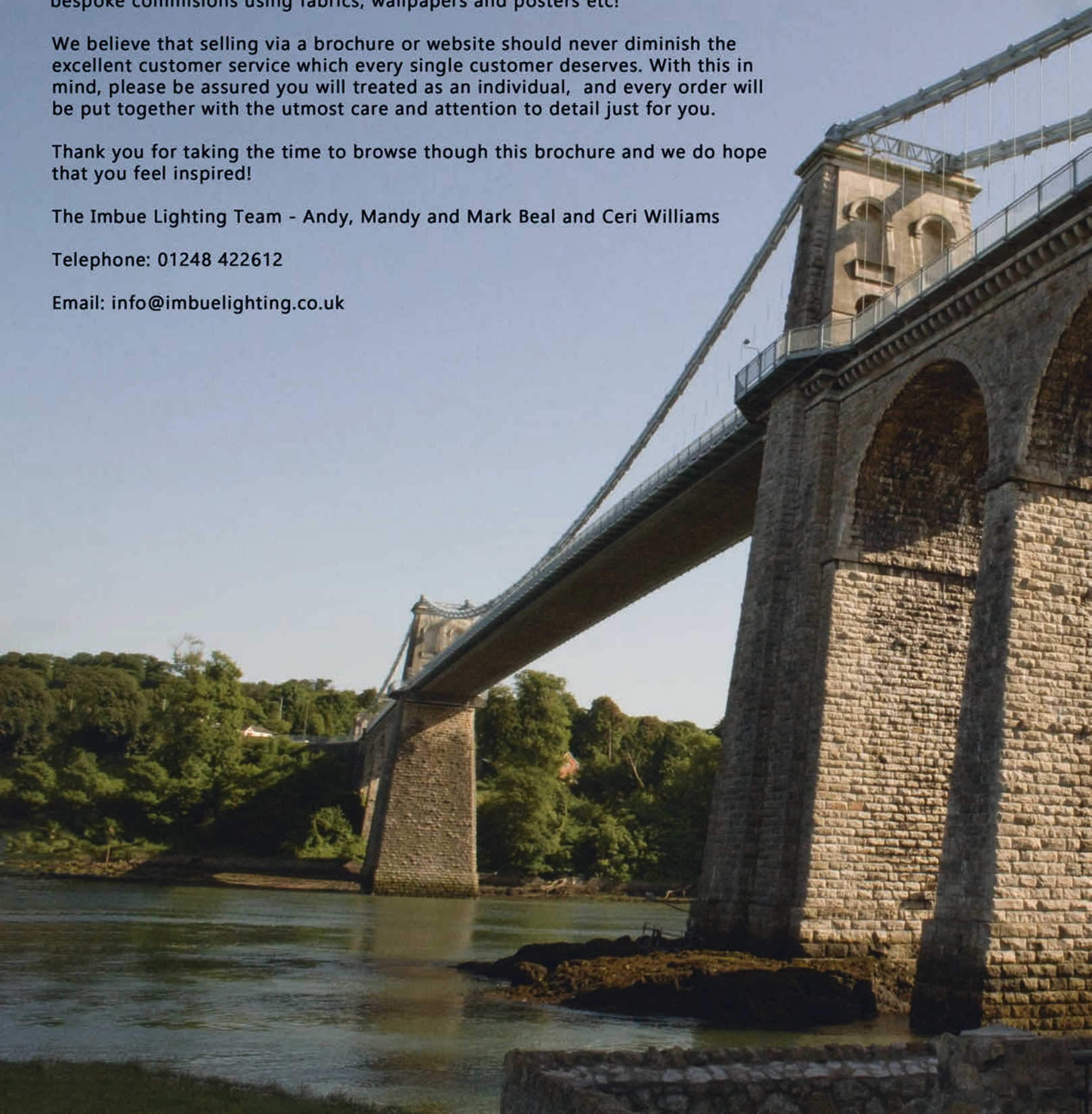

A warm welcome awaits you at
our Menai Bridge shop on the
beautiful Isle of Anglesey.
We have two floors to explore!

01248 422612

21 High Street, Menai Bridge,
Anglesey, LL59 8EE



Table of Contents

Floor Lamps
page 4 - 11

Lamp Shades
page 12 - 27

Table Lamps
page 28 - 31

Swatches
page 32 - 57





How to Order

You can order directly via our website:
imbuelighting.co.uk

If you prefer to place your Order
by Telephone please call:
+(44) 01248 422612

If you have any questions or require a
Bespoke order please Email:
info@imbuelighting.co.uk

We would love to meet you at our shop
where you can see our full range and
place your order in person:
21 High Street, Menai Bridge,
Anglesey, LL59 8EE

QR Codes

We've included QR codes throughout this brochure to make viewing products online easier.

Example:



Scan QR or go to:
<http://bit.ly/oakTripod>

Viewing this QR code through the camera on most smart phones and tablets will allow you to get to the correct web page.

Alternatively, type this link into any web browser to view the collection.
(case sensitive)





Scan QR or go to:
<http://bit.ly/oakTripod>

Oak Tripods

Our amazing Tripod Floor Lamps are designed and made by Andy here at imbue Lighting.

Features:

- * Solid Wood throughout
- * 3D Printed Fixings
- * Brass Rod for Bulb Holder
- * Twisted Black Cable
- * Cable countersunk in groove in the Tripod leg for secure and tidy effect
- * Foot on-off switch
- * E27 LED bulb is included

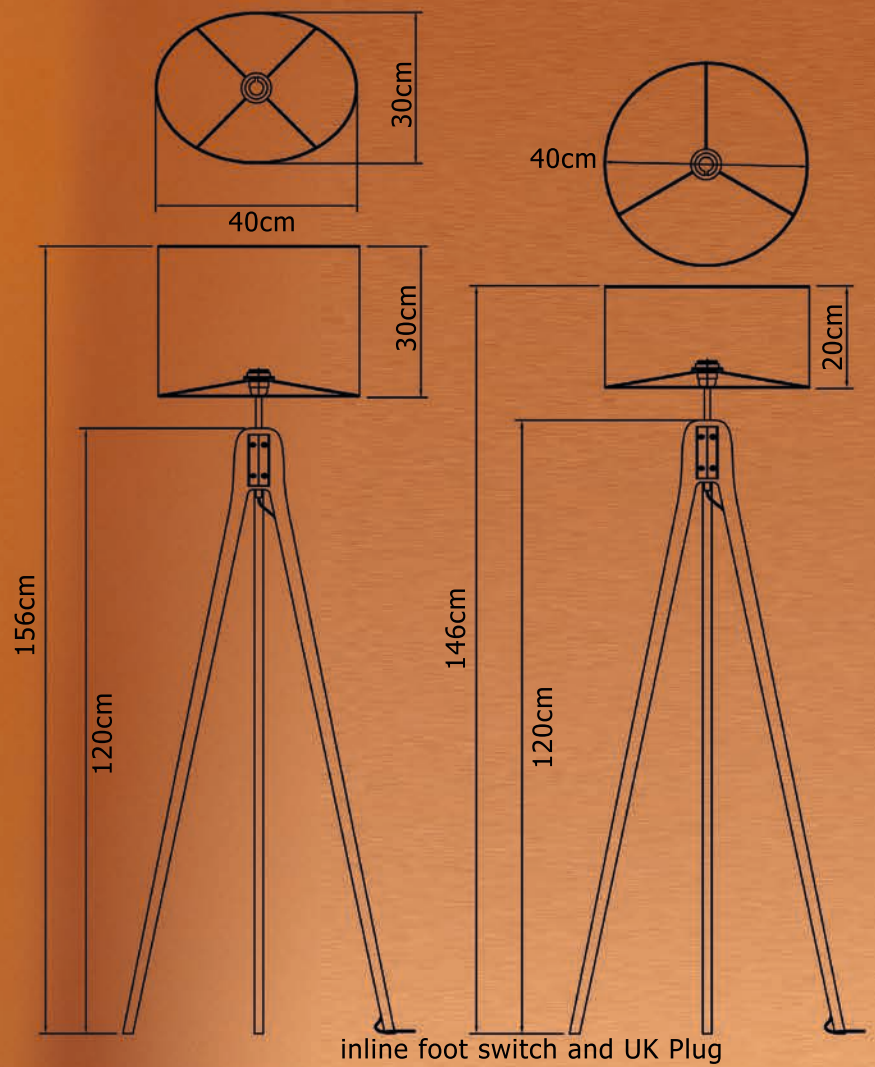





Sapele Tripod

Scan QR or go to:
<http://bit.ly/sapeleTripod>



Drum Floor Lamps



22cm(diameter) x 114cm(height)

ES27 Bulb holder half way up the Lamp. (included)

Inline footswitch



Scan QR or go to:

<http://bit.ly/DrumFloorLamps>

← 22cm →

114cm





3 Panel Floor Lamp

6 x ES14 LED Bulbs included

Inline footswitch

20cm(diameter) x 140cm(height)



Scan QR or go to:

<http://bit.ly/PanelFloorLamps>

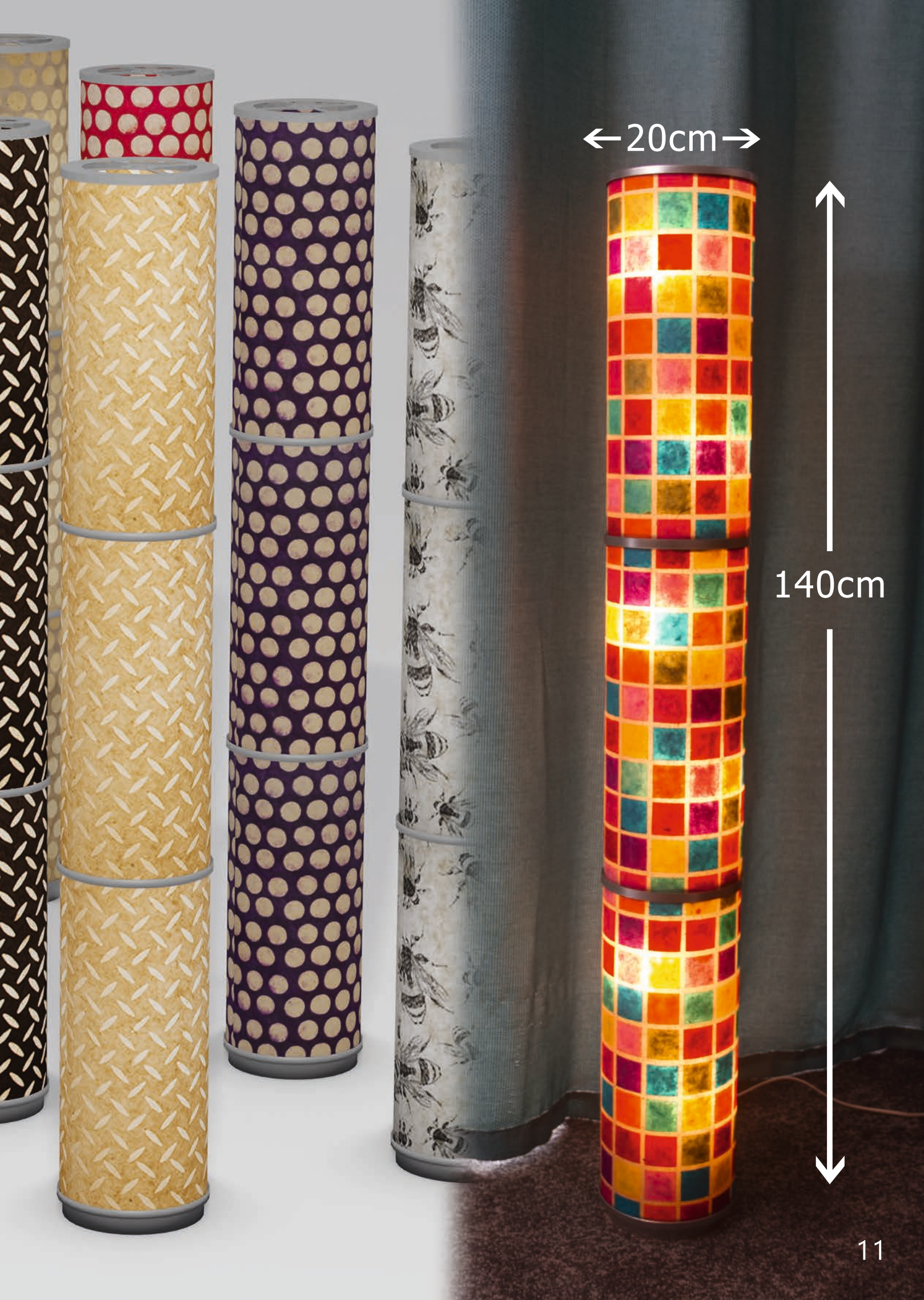

← 20cm →

140cm

Drum Lamp Shades



15cm(diameter)
15cm(height)



Scan QR or go to:
<http://bit.ly/Drum15x15>



15cm(diameter)
30cm(height)



Scan QR or go to:
<http://bit.ly/Drum15x30>

All of our Lampshades are created using clear PVC Lighting backing to ensure they are safe, rigid and strong.



15cm(diameter)
20cm(height)



Scan QR or go to:
<http://bit.ly/Drum15x20>



20cm(diameter)
20cm(height)



Scan QR or go to:
<http://bit.ly/Drum20x20>

All Frames compatible
with BC & ES Fittings.
Remove insert ring for ES.

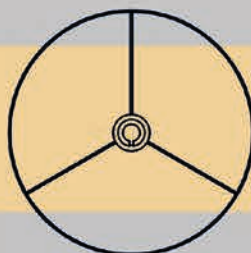

Lamp
Shade
Diffusers
Page 25



30cm(diameter)
20cm(height)



Scan QR or go to:
<http://bit.ly/Drum30x20>



35cm(diameter)
20cm(height)



Scan QR or go to:
<http://bit.ly/Drum35x20>



25cm(diameter)
25cm(height)



Scan QR or go to:
<http://bit.ly/Drum25x25>



30cm(diameter)
30cm(height)



Scan QR or go to:
<http://bit.ly/Drum30x30>

Drum Lamp Shades

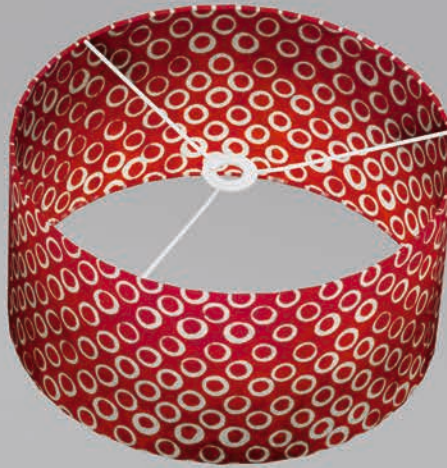

40cm(diameter)
20cm(height)



Scan QR or go to:
<http://bit.ly/Drum40x20>



40cm(diameter)
40cm(height)



Scan QR or go to:
<http://bit.ly/Drum40x40>



50cm(diameter)
25cm(height)



Scan QR or go to:
<http://bit.ly/Drum50x25>

All Frames compatible
with BC & ES Fittings.
Remove insert ring for ES.



Lamp
Shade
Diffusers
Page 25



60cm(diameter)
20cm(height)



Scan QR or go to
<http://bit.ly/Drum60x20>

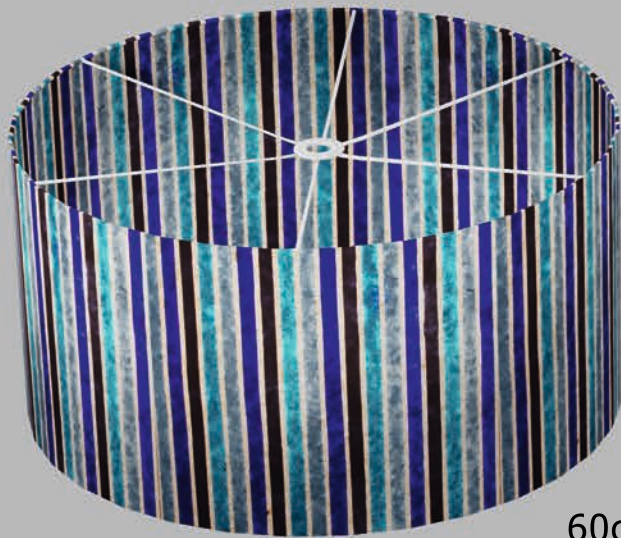

60cm(diameter)
30cm(height)



Scan QR or go to
<http://bit.ly/Drum60x30>

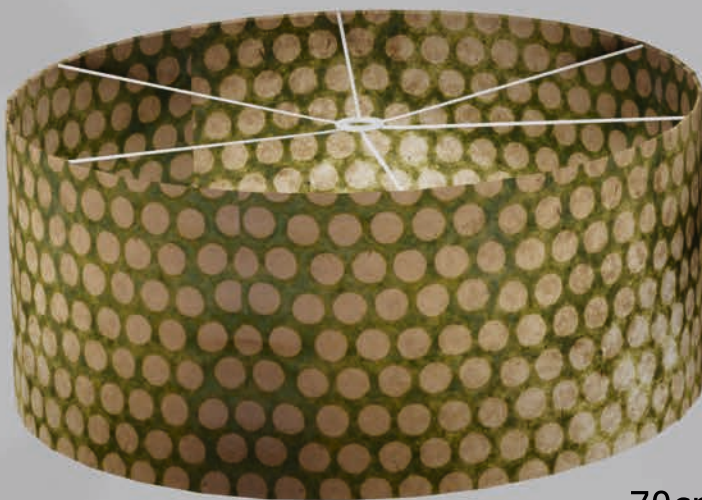
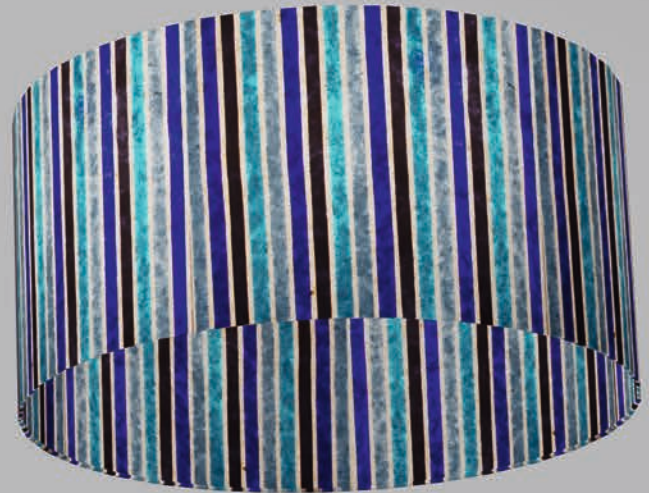

70cm(diameter)
30cm(height)



Scan QR or go to
<http://bit.ly/Drum70x30>



Oval Lamp Shades



20cm(width)
20cm(height)
13cm(depth)



Scan QR or go to:
<http://bit.ly/Oval20x20x13>

All of our Lampshades are created using clear PVC Lighting backing to ensure they are safe, rigid and strong.



20cm(width)
30cm(height)
13cm(depth)



Scan QR or go to:
<http://bit.ly/Oval20x30x13>



30cm(width)
20cm(height)
22cm(depth)



Scan QR or go to:
<http://bit.ly/Oval30x20x22>

All Frames compatible with BC & ES Fittings.
Remove insert ring for ES.

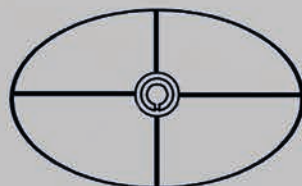

Lamp
Shade
Diffusers
Page 25

30cm(width)
30cm(height)
22cm(depth)



Scan QR go to:
<http://bit.ly/Oval30x30x22>



40cm(width)
20cm(height)
30cm(depth)



Scan QR or go to:
<http://bit.ly/Oval40x20x30>



40cm(width)
30cm(height)
30cm(depth)



Scan QR or go to:
<http://bit.ly/Oval40x30x30>

Square Lamp Shades



20cm (Cube)



Scan QR or go to:
<http://bit.ly/Square20>



20cm (width)
30cm (height)



Scan QR or go to:
<http://bit.ly/Square20x30>



30cm (Cube)



Scan QR or go to:
<http://bit.ly/Square30>

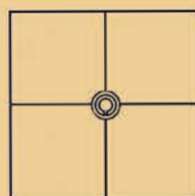

All Frames compatible
with BC & ES Fittings.
Remove insert ring for ES.

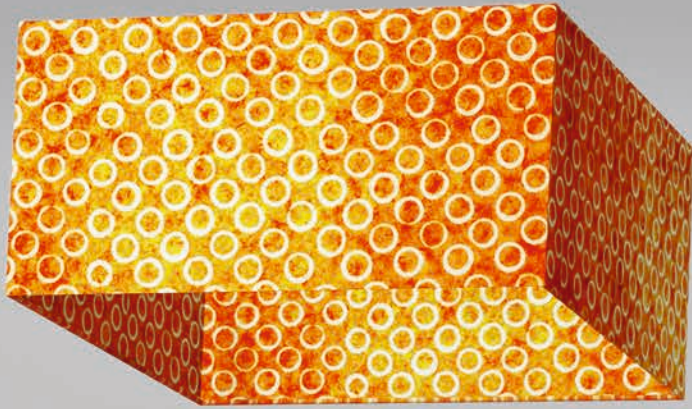

40cm (width)
20cm (height)



Scan QR or go to:
<http://bit.ly/Square40x20>

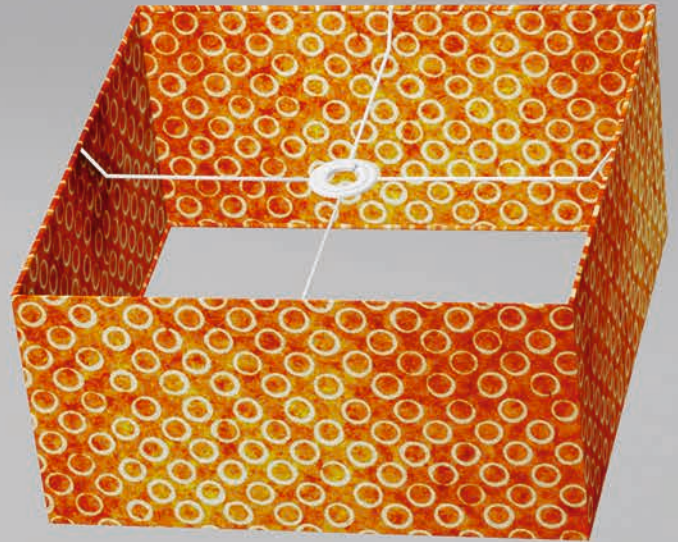

40cm (Cube)



Scan QR or go to:
<http://bit.ly/Square40>

Lamp
Shade
Diffusers
Page 25



Rectangular Lamp Shades



30cm(width)
20cm(height)
15cm(depth)



Scan QR or go to:
<http://bit.ly/Rect30x20x15>

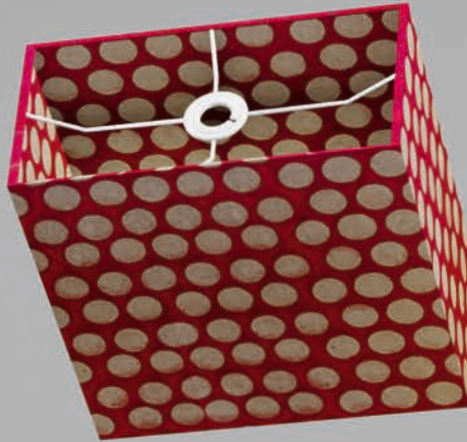
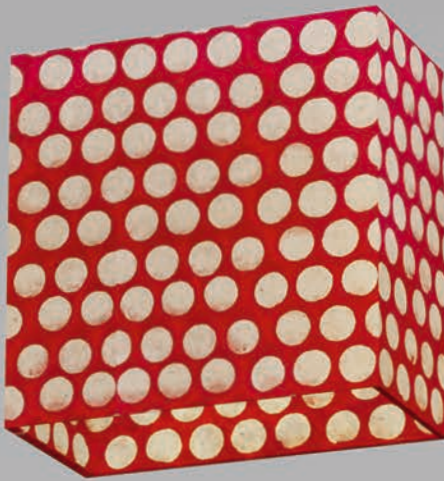

30cm(width)
30cm(height)
15cm(depth)



Scan QR or go to:
<http://bit.ly/Rect30x30x15>

Lamp
Shade
Diffusers
Page 25

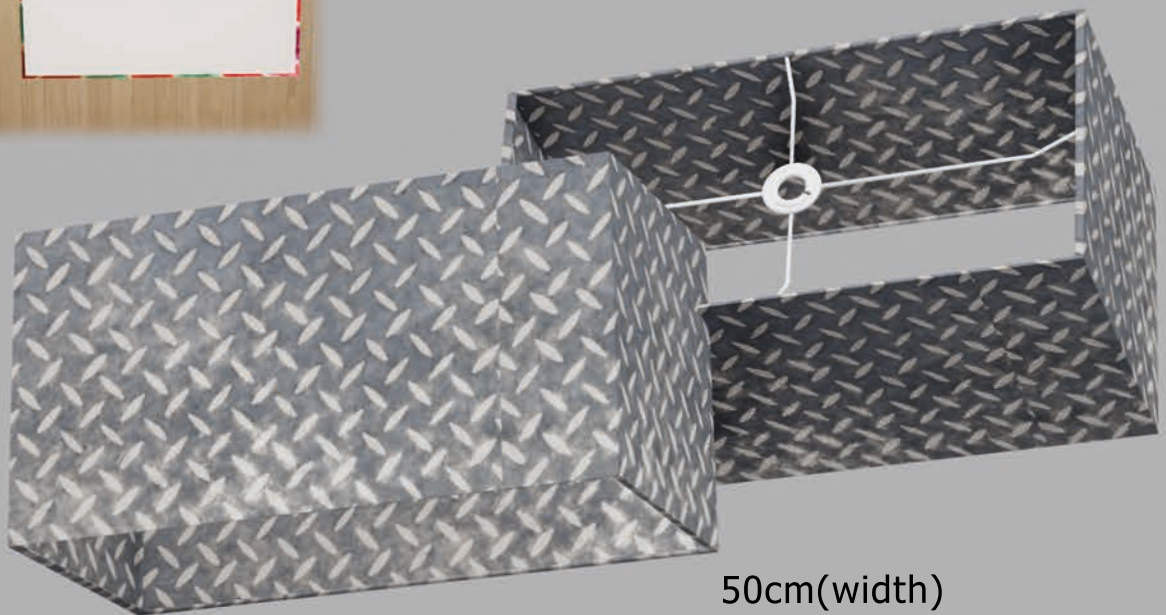

50cm(width)
25cm(height)
25cm(depth)



Scan QR or go to:
<http://bit.ly/Rect50x25x25>



All Frames compatible
with BC & ES Fittings.
Remove insert ring for ES.

Triangular Lamp Shades



20cm(width)
20cm(height)



Scan QR or go to:
<http://bit.ly/20Triangle>



20cm(width)
30cm(height)



Scan QR or go to:
<http://bit.ly/20x30Triangle>



40cm(width)
20cm(height)



Scan QR or go to:
<http://bit.ly/40x20Triangle>

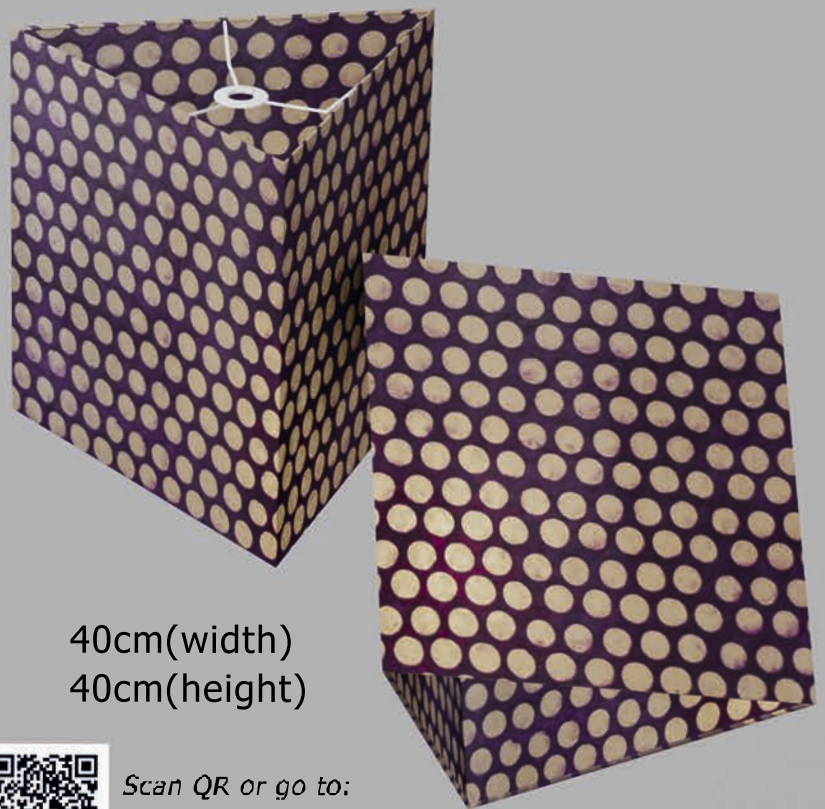

40cm(width)
40cm(height)



Scan QR or go to:
<http://bit.ly/40Triangle>



Lamp
Shade
Diffusers
Page 25

Conical Lamp Shades

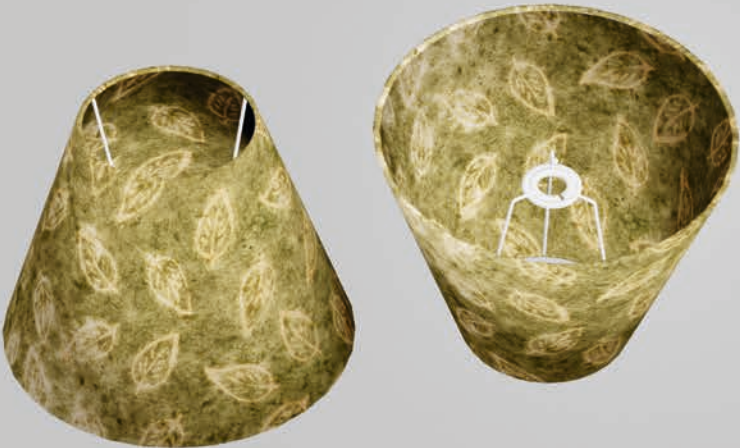

15cm(top)
30cm(bottom)
22cm(height)



Scan QR or go to:
<http://bit.ly/ConicalA>

In addition to the sizes shown we can make bespoke sizes upon request.



23cm(top)
35cm(bottom)
31cm(height)



Scan QR or go to:
<http://bit.ly/ConicalB>



23cm(top)
40cm(bottom)
31cm(height)



Scan QR or go to:
<http://bit.ly/ConicalC>

All of our Lampshades are created using clear PVC Lighting backing to ensure they are safe, rigid and strong.

Tiered Lamp Shades



Top) 30cm x 20cm
Bottom) 20cm x 15cm



Scan QR or go to:
<http://bit.ly/TieredA>



Top) 40cm x 20cm
Bottom) 30cm x 15cm



Scan QR or go to:
<http://bit.ly/TieredB>



Top) 40cm x 20cm
Middle) 30cm x 17.5cm
Bottom) 20cm x 15cm



Scan QR or go to:
<http://bit.ly/TieredC>



Top) 50cm x 20cm
Middle) 40cm x 17.5cm
Bottom) 30cm x 15cm



Scan QR or go to:
<http://bit.ly/TieredD>

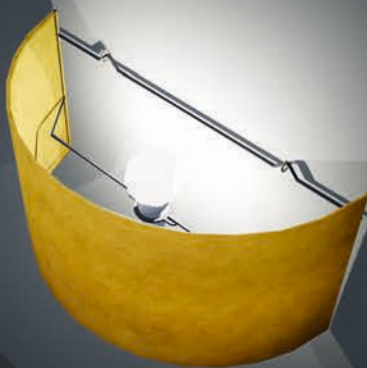

Wall Lights

36cm (width) x 20cm (height)

Wall mount from hooks
or a sconce. BC Lamp Holder



Scan QR or go to:
<http://bit.ly/imbucWL>



Dimensions / Specs
Information

Lamp Shade Diffusers

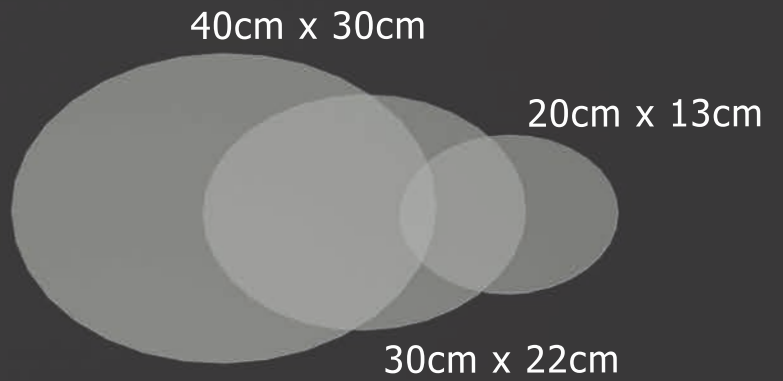
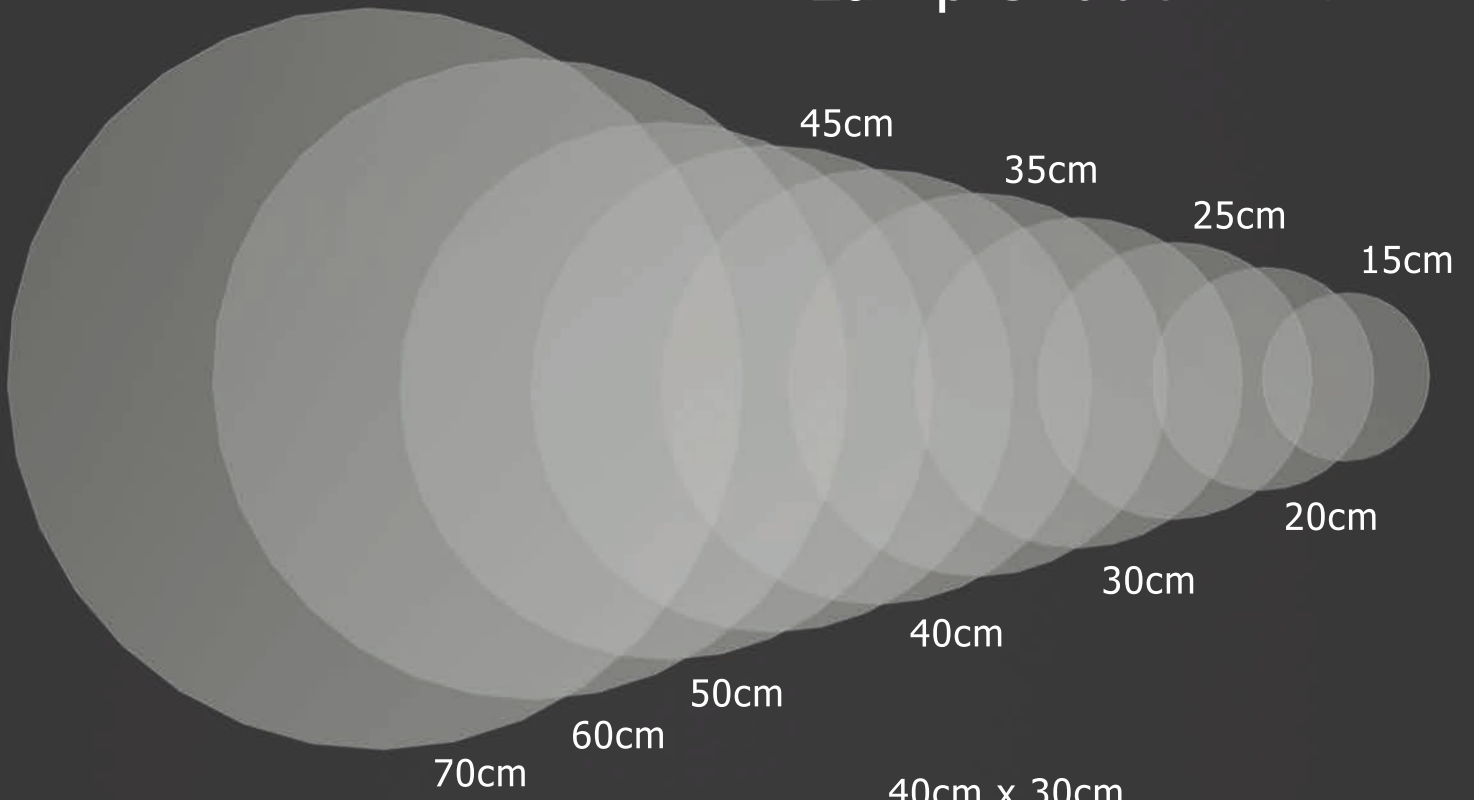

Translucent polypropylene

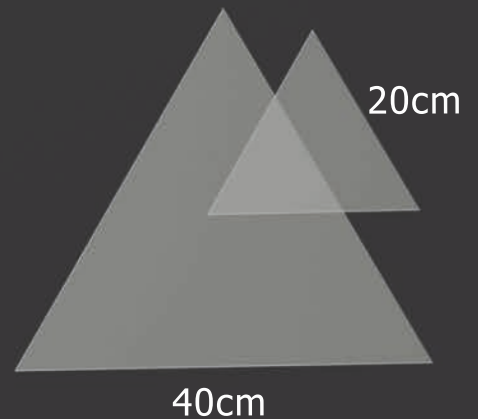
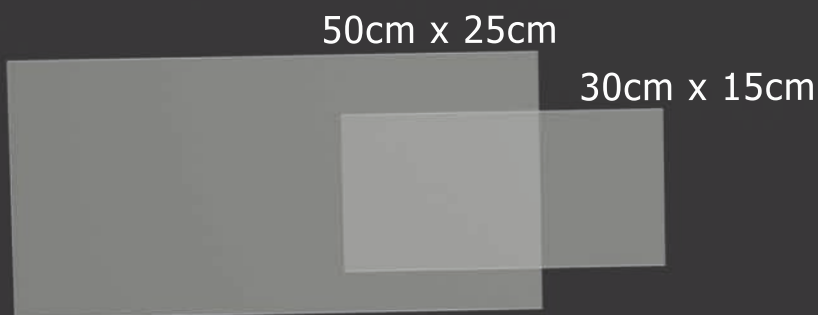
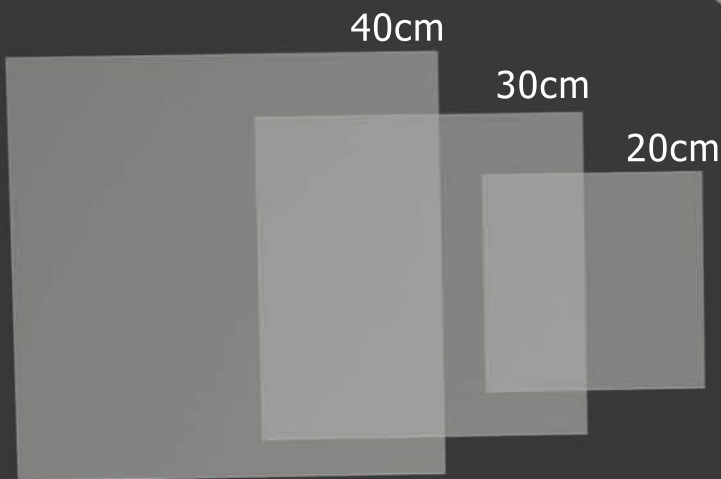

Scan QR or go to:
<http://bit.ly/imbueDiffusers>

Clip on Lamp Shades



This range of shades uses a frame which directly clips onto a candle bulb or golf ball bulb. These shades are often found on wall sconces and chandelier pendants. Bring your existing fitment to life by replacing your existing shades with our beautiful designs and colours!



Scan QR or go to:
<http://bit.ly/cliponshade>





Map Lamp Shades

<http://bit.ly/mapshades>

All of our map lamp shades are created using original maps. All map lamp shades 30cms tall or over are created using a lokta base shade with the map being wrapped around and laced. We can create lamp shades using your own maps - so please contact us to discuss.



Table Lamps

All of our Oak and Sapele wooden bases are handmade by Andy here at imbue lighting.

Our standard range as shown can be teamed with a wide variety of our shades to great effect, so you can mix and match to achieve the perfect look!



15cm Oak
with riser



15cm Oak with riser
15cm x 30cm Lamp Shade



20cm Oak base
20cm x 30cm
Lamp Shade

Square Oak base
15cm x 30cm
Lamp Shade

15cm Oak base with riser
15cm x 30cm Lamp Shade

30cm Oak with riser
30cm x 30cm Lamp Shade

20cm Sapele with riser
20cm x 20cm
Lamp Shade



Square Sapele base
15cm x 20cm
Lamp Shade



15cm Sapele with riser
15cm x 30cm Lamp Shade

30cm Sapele base
30cm x 30cm Lamp Shade



20cm Sapele with riser
30cm x 30cm x 22cm Oval Lamp Shade



20cm Sapele
with riser

To view our full range of table lamps visit:
<https://imbuelighting.co.uk/collections/table-lamps>



Free Standing Table Lamps



15cm wide x 35cm high

Scan QR or go to:
<http://bit.ly/FreeStandingSmall>



20cm wide x 45cm high

Scan QR or go to:
<http://bit.ly/FreeStandingLarge>

Laser Cut Plywood Table Lamps



11.5cm wide x
17.6cm high



Scan QR or go to:
<http://bit.ly/LaserSmall>



17.6cm wide x
27cm high



Scan QR or go to:
<http://bit.ly/LaserLarge>

BC22 Bulb Holder & Inline Switch.

Designed by Sam James Design
<https://www.behance.net/samjames2073b1>



Batik Circles

P03 - Batik Circles Orange

<http://bit.ly/imbueP3>

If you would like to have a selection of swatches from our design and colour options, please either visit <https://imbuelighting.co.uk/pages/swatch-gallery> or give us a call on 01248 422612 or email info@imbuelighting.co.uk





P02 - Lime



Scan QR or go to:
<http://bit.ly/imbueP2>



P03 - Orange



Scan QR or go to:
<http://bit.ly/imbueP3>



P71 - Yellow



Scan QR or go to:
<http://bit.ly/imbueP71>



P72 - Blue



Scan QR or go to:
<http://bit.ly/imbueP72>



P73 - Cranberry



Scan QR or go to:
<http://bit.ly/imbueP73>



P74 - Natural



Scan QR or go to:
<http://bit.ly/imbueP74>



P83 - Red



Scan QR or go to:
<http://bit.ly/imbueP83>

This batik design is created by applying wax to natural lokta. Once dried in the shade, each sheet is then dyed into the vibrant colours as shown.

All of our Lampshades are created using clear PVC Lighting backing to ensure they are safe, rigid and strong.





P78 - Grey



Scan QR or go to:
<http://bit.ly/imbueP78>



P79 - Purple



Scan QR or go to:
<http://bit.ly/imbueP79>



P84 - Red



Scan QR or go to:
<http://bit.ly/imbueP84>



P85 - Natural



Scan QR or go to:
<http://bit.ly/imbueP85>



P86 - Yellow



Scan QR or go to:
<http://bit.ly/imbueP86>



P87 - Green



Scan QR or go to:
<http://bit.ly/imbueP87>

This timeless batik dots design is created by applying wax to our natural lokta. Once dried in the shade, each sheet is then dyed into various colours - and when lit, provides a striking effect.

All of our Lampshades are created using clear PVC Lighting backing to ensure they are safe, rigid and strong.





Batik Leaf Natural

P28 - Natural

<http://bit.ly/imbueP28>

If you would like to have a selection of swatches from our design and colour options, please either visit <https://imbuelighting.co.uk/pages/swatch-gallery> or give us a call on 01248 422612 or email info@imbuelighting.co.uk



Batik Leaf



P28 - Natural



Scan QR or go to:
<http://bit.ly/imbucP28>



P29 - Green



Scan QR or go to:
<http://bit.ly/imbucP29>



P30 - Red



Scan QR or go to:
<http://bit.ly/imbucP30>



P31 - Blue



Scan QR or go to:
<http://bit.ly/imbueP31>



P66 Camel



Scan QR or go to:
<http://bit.ly/imbueP66>



P67 - Pink



Scan QR or go to:
<http://bit.ly/imbueP67>



P68 - Purple



Scan QR or go to:
<http://bit.ly/imbueP68>

Our lovely batik leaf design is created by applying wax to our natural lokta. Once dried in the shade, each sheet is then dyed into the various colour options to match or compliment your decor

All of our Lampshades are created using clear PVC Lighting backing to ensure they are safe, rigid and strong.



Batik Tread Plate

P89 - Batik Tread Plate Yellow

<http://bit.ly/imbueP89>

Our batik Treadplate design is created by applying wax to our natural lokta. Once dried in the shade, each sheet is then dyed into the vibrant colours as shown and creates a modern and striking look for each shade.



Backed with Clear PVC ensuring a safe and strong Lamp Shade.

Batik Tread Plate



P10 - Natural



Scan QR or go to:
<http://bit.ly/imbueP10>



P11 - Black



Scan QR or go to:
<http://bit.ly/imbueP11>



P12 - Terracotta



Scan QR or go to:
<http://bit.ly/imbueP12>



P13 - Purple



Scan QR or go to:
<http://bit.ly/imbueP13>



P14 - Cranberry



Scan QR or go to:
<http://bit.ly/imbueP14>



P15 - Mint Green



Scan QR or go to:
<http://bit.ly/imbueP15>



P88 - Grey



Scan QR or go to:
<http://bit.ly/imbucP88>



P89 - Yellow



Scan QR or go to:
<http://bit.ly/imbucP89>



P90 - Red



Scan QR or go to:
<http://bit.ly/imbucP90>

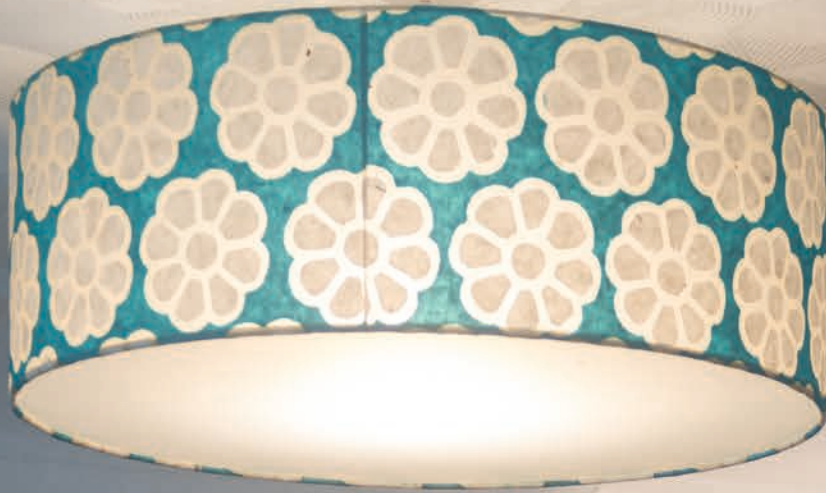

Batik Big Flower

P93 ~ Batik Big Flower on Turquoise

This large sized batik abstract flower design is created by applying wax to our natural lokta. Once dried in the shade, each sheet is then dyed into the vibrant colours as shown - and is especially effective on larger shades!



All of our Lampshades are created using clear PVC Lighting backing to ensure they are safe, rigid and strong.

Batik Big Flower



P17 - Natural



Scan QR or go to:
<http://bit.ly/imbueP17>



P18 - Red



Scan QR or go to:
<http://bit.ly/imbueP18>



P19 - Green



Scan QR or go to:
<http://bit.ly/imbueP19>



P20 - Brown



Scan QR or go to:
<http://bit.ly/imbueP20>



P21 - Lilac



Scan QR or go to:
<http://bit.ly/imbueP21>



P22 - Hot Pink



Scan QR or go to:
<http://bit.ly/imbueP22>



P23 - Teal



Scan QR or go to:
<http://bit.ly/imbueP23>



P24 - Black



Scan QR or go to:
<http://bit.ly/imbueP24>

Batik Star Flower



P75 - Natural



Scan QR or go to:
<http://bit.ly/imbueP75>



P76 - Red



Scan QR or go to:
<http://bit.ly/imbueP76>



P80 - Mint Green



Scan QR or go to:
<http://bit.ly/imbueP80>

Our pretty batik starflower design is created by applying wax to natural lokta. Once dried in the shade, each sheet is then dyed into the assorted colours as shown. The stylised flower compliments many decors from traditional to modern.



P77 - Grey



Scan QR or go to:
<http://bit.ly/imbueP77>

Batik Stripe



P04 - Pink



Scan QR or go to:
<http://bit.ly/imbueP04>



P05 - Blue



Scan QR or go to:
<http://bit.ly/imbueP05>



P06 - Autumn



Scan QR or go to:
<http://bit.ly/imbueP06>



P08 - Grey



Scan QR or go to:
<http://bit.ly/imbueP08>

Our striking batik stripe designs are created by applying wax to natural lokta. Once dried in the shade, each stripe is hand dyed into the vibrant colours as shown. When lit each coloured stripe glows to great effect



P07 - Brown

Scan QR or go to:
<http://bit.ly/imbueP07>





There are times when your lighting is best when there is no pattern - and our plain dyed colours are perfect for this. The hand made paper will ensure there is still some texture when lit, so plain doesnt mean uninteresting!



P63 - Terracotta



Scan QR or go to:
<http://bit.ly/imbueP63>



P64 - Purple



Scan QR or go to:
<http://bit.ly/imbueP64>



P65 - Turquoise



Scan QR or go to:
<http://bit.ly/imbueP65>

Plain Dyed Lokta



P54 - Natural



Scan QR or go to:
<http://bit.ly/imbueP54>



P55 - Black



Scan QR or go to:
<http://bit.ly/imbueP55>



P56 - Green



Scan QR or go to:
<http://bit.ly/imbueP56>



P57 - Pink



Scan QR or go to:
<http://bit.ly/imbueP57>



P58 - Brown



Scan QR or go to:
<http://bit.ly/imbueP58>

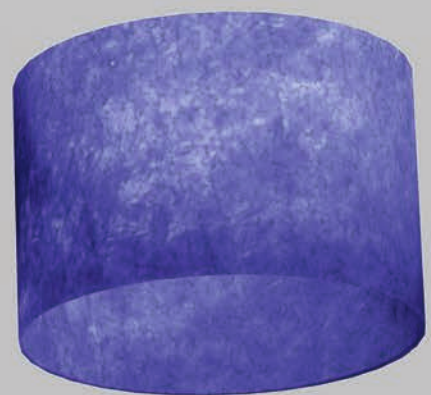

P59 - Blue



Scan QR or go to:
<http://bit.ly/imbueP59>



P60 - Red



Scan QR or go to:
<http://bit.ly/imbueP60>



P61 - Lime



Scan QR or go to:
<http://bit.ly/imbueP61>



P62 - Yellow



Scan QR or go to:
<http://bit.ly/imbueP62>

Resistance Dyed



P25 - Pink Fern



Scan QR or go to:
<http://bit.ly/imbucP25>

P26 - Brown Fern



Scan QR or go to:
<http://bit.ly/imbucP26>



P27 - Green Fern



Scan QR or go to:
<http://bit.ly/imbucP27>



The beautiful effect of ferns is created by leaves being placed onto the newly dyed lokta paper. During the drying process the sun's rays react with the natural chemicals in the leaves and imprint it onto the paper. This is called resistance dyed, and shades made using these papers will give off a subtle ambient light.



P32 - Marigold



Scan QR or go to:
<http://bit.ly/imbueP32>



P33 - Rose



Scan QR or go to:
<http://bit.ly/imbueP33>



P34 - Cornflower



Scan QR or go to:
<http://bit.ly/imbueP34>

Our petal papers are often called our prettiest! Each lokta sheet has Cornflower, Rose or Marigold petals embedded during the paper making process and shades made from these designs are as pretty when switched off as when they are lit!



Batik Multi Square



Scan QR or go to:
<http://bit.ly/imbueP1>



This stunning batik design is created by applying wax to our natural lokta. Once dried in the shade, each square is then hand dyed into the vibrant colours as shown.



Batik Peony

The stylish Peony flowers are random therefore this pattern can be especially effective on Drum and Conical lamp shades.



Scan QR or go to:
<http://bit.ly/imbueP9>



Garden Gold Screen Print



Once the beautiful natural lokta paper has been dried in the sun it is then Screen Printed in a Gold colour with this sophisticated and classy paisley effect design!

Scan QR or go to:

<http://bit.ly/imbueP69>



Batik Multi Coloured Flowers



P35 - Natural



Scan QR or go to:
<http://bit.ly/imbueP35>

Wax is applied to the lokta paper and then the individual flower colours are painted in - such a lovely way to add multiple colours into your room!



P36 - Pink

Scan QR or go to:
<http://bit.ly/imbueP36>



P38 - Purple



Scan QR or go to:
<http://bit.ly/imbueP38>

Embroidered Flower



Scan QR or go to:
<http://bit.ly/imbueP43>



Our ever popular Flowers on White has been free-hand machine embroidered onto a non woven fabric. Once we have applied our safe and rigid lighting backing - the light shines through to great effect!



Scan QR or go to:
<http://bit.ly/imbueP42>

Bees Screen Print

Such a unique design which is created by Screen Printing the Bees onto natural lokta.



Batik Hearts



Scan QR or go to:
<http://bit.ly/imbueP16>



Pink Hearts



Scan QR or go to:
<http://bit.ly/imbueP82>





Gold Fish



Scan QR or go to:
<http://bit.ly/imbueP40>



Polka Dots



Scan QR or go to:
<http://bit.ly/imbueP39>

Screen Printed Yuzen Washi



Pink Hills

Scan QR or go to:
<http://bit.ly/imbueW04>



Peach Daisies

Scan QR or go to:
<http://bit.ly/imbueW07>



Cranes

Scan QR or go to:
<http://bit.ly/imbucW05>



Kyoto

Scan QR or go to:
<http://bit.ly/imbucW06>





Pink Cherry Blossom

Scan QR or go to:
<http://bit.ly/imbueW02>



Gold Waves

Scan QR or go to:
<http://bit.ly/imbueW03>



We have carefully selected our seven Yuzen Washi designs directly from our supplier in Kyoto, Japan.

All of our yuzen washi designs feature opaque and translucent pigments which gives a unique look to every lamp shade whether lit or unlit.

If you would like to have a selection of swatches from our design and colour options, please either visit <https://imbuelighting.co.uk/pages/swatch-gallery>

or give us a call on 01248 422612
or email info@imbuelighting.co.uk



Red Daisies

Scan QR or go to:
<http://bit.ly/imbueW01>



Lighting backing is applied for safety, strength and rigidity



After frame positioning, glue is applied with care



Rolling/tucking around the frame to the highest quality





Delivery

UK MAINLAND DELIVERY - FREE

Once we have received your order it normally takes us approximately one to five days to hand make your order. We will then dispatch via DELSOL, Royal Mail or ParcelForce. If the timescale for dispatch is any different to this we will always communicate with you.

Rest of world - Please contact us to arrange a quotation for delivery to your specific location.

Returns and Exchanges

Please be assured that we want to be happy with your purchase, therefore please contact us if you are not satisfied with your order or require an exchange or return. info@imbuelighting.co.uk or call 01248 422612.

VAT

As a VAT registered business all of the prices shown online are inclusive of VAT at the current % rate. (GB165868558)

Trade enquiries

We welcome enquiries from retailers and businesses who would like to be stockists of our Anglesey made interior lighting. We are also happy to supply Interior Designers with unique solutions for their clients lighting requirements - please contact us for further information.

Is your Hotel, Business or Home undergoing a refurbishment? -
Why not invite us along for a no obligation visit to discuss and plan your interior lighting. We will bring swatches and shades to ensure you are matching or complimenting your decor perfectly! Please call to discuss this opportunity to maximise our lighting expertise.

Privacy Policy

Our full privacy policy is available to view here:
<https://imbuelighting.co.uk/pages/privacy-policy>

Imbue Lighting is a trading name of More Than Bags Ltd (Company Reg. 08359332)

Tel: 01248 422612
Email: info@imbuelighting.co.uk
Website: imbuelighting.co.uk

Address: Imbue Lighting, 21 High Street, Menai Bridge, Anglesey, LL59 5EE.





imbuelighting.co.uk