

CS50-TS Side/Top belt driven Case Sealer



Operating
Manual

PREFACE

Thank you for purchasing the semi-auto up and side belts driven carton sealer. This manual will show you the basic structure, using method and points for attention to use this machine safely and correctly. Please read this manual carefully before operating the machine. Be sure that the manual is hand to the final users.

GEQ carton sealer series use OPP tape to seal different kinds of cartons. The machine is operated and maintained easily with simple structure and high quality, for which it is widely used in various industries.

Safety precautions

1. The operator and maintenance personnel should read the operating manual carefully before operating and maintaining this machine.
2. The operator must keep away from the back folding plate to avoid injury.
3. The power and gas must be closed when installing the tape and doing the daily maintenance.
4. Only the trained personnel can operate the machine.

CONTENTS

| | |
|--|----|
| 1.Specifications. | 2 |
| 2 Machine structure and adjustment instruction..... | 3 |
| 3 The operation flow | 3 |
| 4 Adhesive tape installation and adjustment | 4 |
| 5 Circuit diagram..... | 9 |
| 6 Exploded figure | 10 |
| 6.1 Exploded figure of the body and parts list..... | 10 |
| 6.2 Exploded figure of driven belt system and parts list | 13 |
| 6.3 Exploded figure of adhesive tape adhibiting set and parts list | 16 |

1.Specifications



The semi-auto carton sealer can be operated separately, with simple operation and high performance, for which it may be ideal packaging machine for you. The main specifications are listed as follows:

Sealing width: 15cm~50cm

Sealing height: 15cm~50cm

Sealing length: 15cm~∞

Machine size: L 102cm x W 90cm x H 135cm

Sealing speed: 18m/min

Power supply: 220—240v 50/60HZ

Tape width: 48/ 60/ 72mm Machine

weight: 140kg

2. Machine structure and adjustment instruction (P.1)

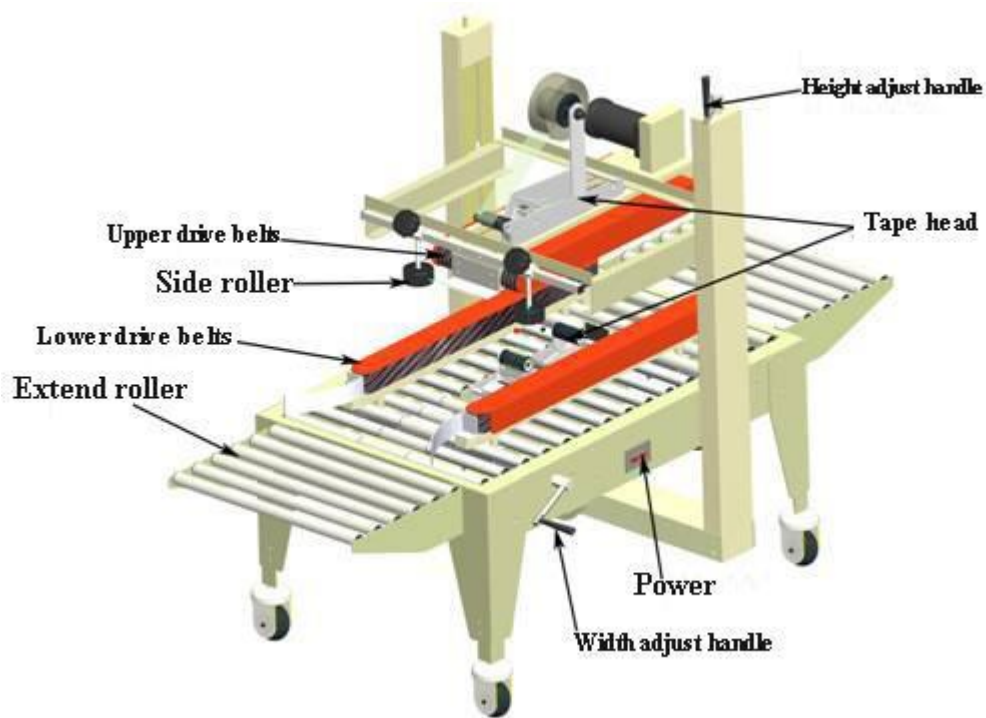

P.1

3. The operation flow

3.1 Folding the filled carton covers manually and then push it into the sealing system, adjust the width and height of the sealing system. (P.2)

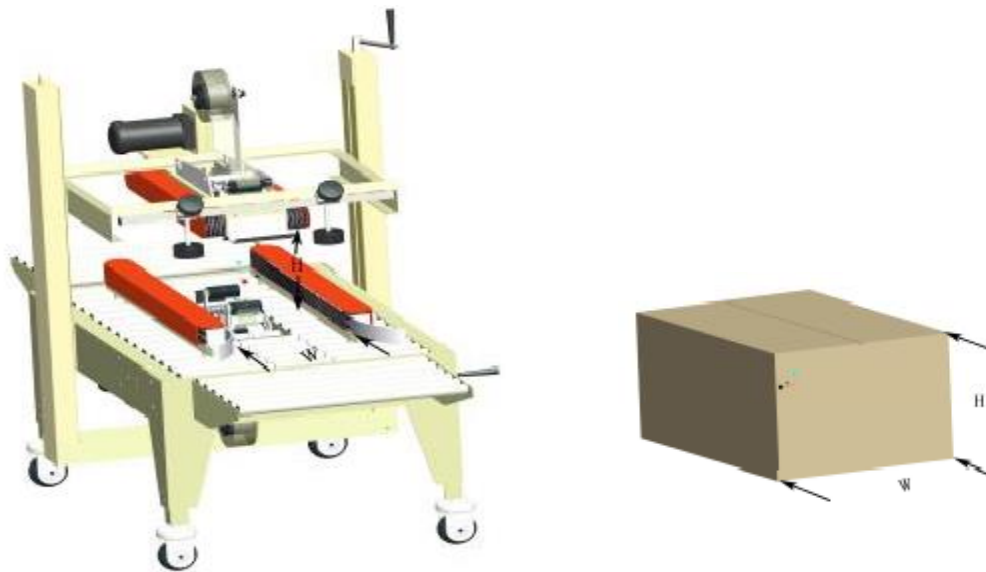

P.2

3.2 Start the machine, push the folded carton into the sealing system, the carton is conveyed by the driven belts, then sealed up and bottom. (P.3)

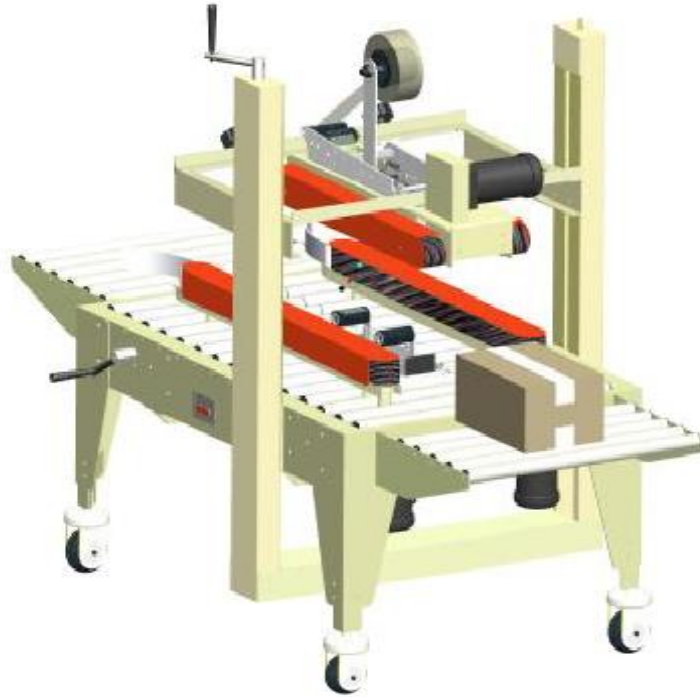

P.3

4 Adhesive tape installation and adjustment (P.4)

4.1 At first, install the roll of OPP adhesive tape at the core axis (see P.4), pull out of the adhesive tape, circle around roller C, then circle around roller B, D, get through tape seating E and get out of the front side of roller F. Pay highly attention that the side with glutinosity should face toward outside.

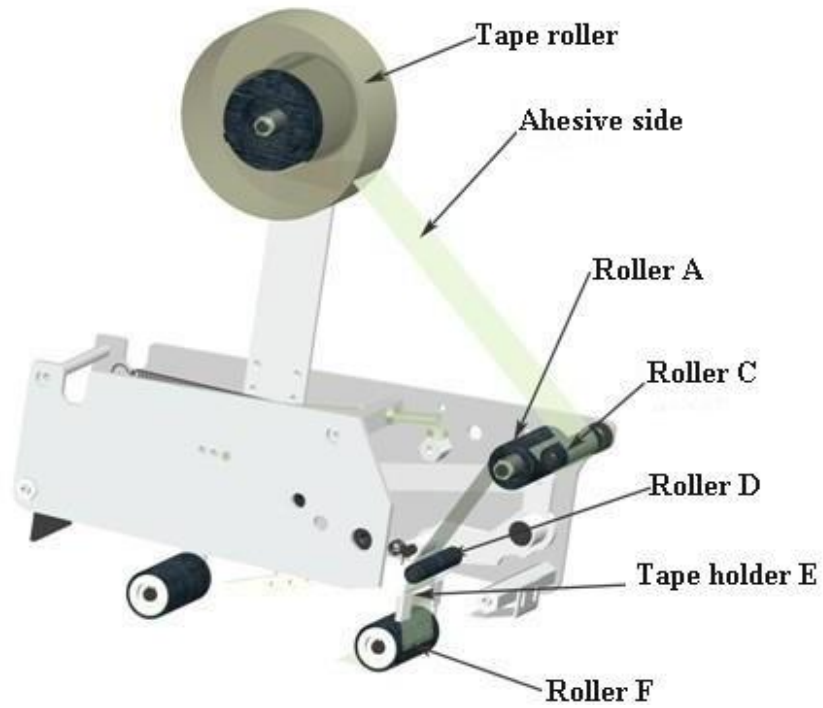

P.4

4.2 Drawing of the adhesive tape threading (P.5)



P.5

4.3 Adhesive Tape position adjustment (P.6)

If the adhesive tape is not on the carton central line, please refer to below picture for adjustment. First, loosen the nut, then move the core axis with nut until the adhesive tape is moved to the carton central line.

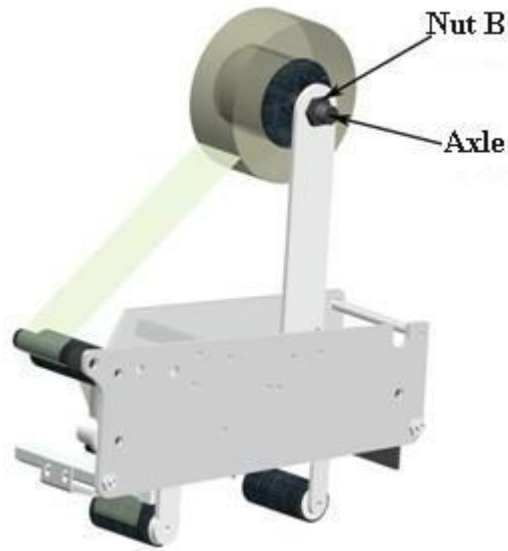

P.6

4.4 Adhesive tape tension adjustment (P.7)

Turn the knob, loosen the nut M8, and adjust the bolt M8*50 to change the elasticity of swing-rod long extension spring so as to control the tape's tension..Turn the knob clockwise and the tension of adhesive tape will be larger; turn the knob anticlockwise, and the tension of adhesive tape will lessen. when the bolt M8*50 is adjusted forward, the strain of adhesive tape will be larger; conversely, the strain of adhesive tape will lessen.

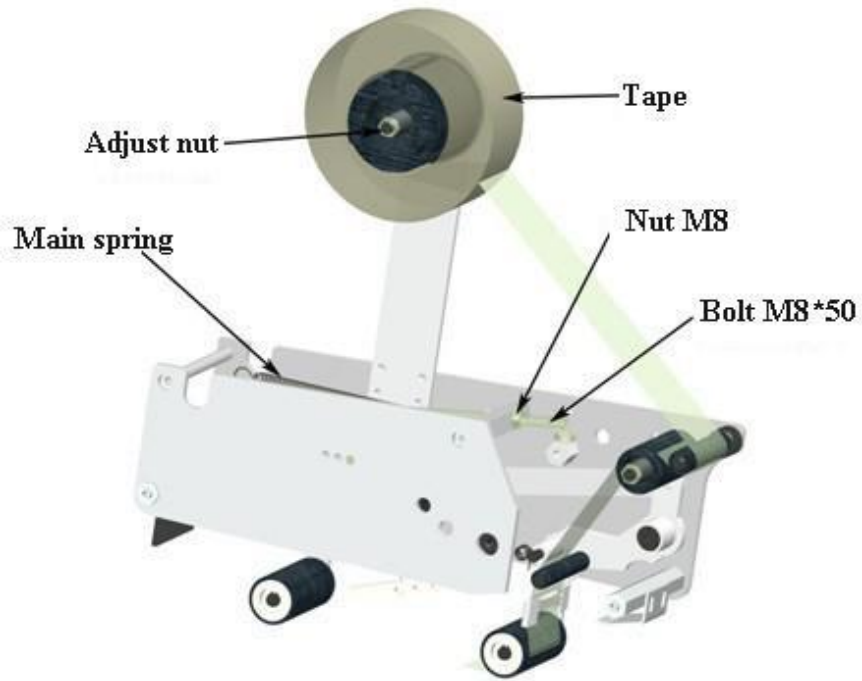

P.7

Malfunctions and solutions

| Malfunction and Solution of the Sealer | | | |
|--|---|---|---|
| Number | Malfunction | Possible reason | Solution |
| 1 | Adhesive tape can not be cut off | The reamer patch is not sharp enough. The reamer tine is jammed by the bond. | Change the reamer patch Launder the reamer patch |
| 2 | There is tail after the adhesive tape is cut off. | The reamer patch is not sharp enough. There is stem on the reamer seating. The pulling spring is too loose. | Check if the nut on the reamer seating is too loose or not. Lubricate the nut if necessary. |
| 3 | The adhesive tape can't stick to the carton completely. | Main spring is too loose and there is glue on the axis of the roller. The adhesive tape is disqualification | Adjust the pull of main spring and clear up the roller. Change the adhesive tape |

| | | | |
|----|--|---|---|
| 4 | The carton is locked in the midway. | The nut on the pasting wheel is too tight, the height adjustment of the carton's transporting line is not suitable, and the main spring is too tight. | Loosen the pasting wheel, regulate the nut, re-adjust the height and loosen the main spring. |
| 5 | The adhesive tape is cut down during sealing. | The reamer patch protrudes excessively long. | Lower the place of the reamer patch. |
| 6 | The adhesive tape is often off the track. | The pressure of the guiding roller on the carton is not equal. | Re-adjust the space of the guiding roller. |
| 7 | The adhesive tape is not on the central line. | The anti-retorse wheel is broken. | Change the anti-retorse. |
| 8 | There is abnormality during the sealing. | There is dust on the axletree seating. | Clean the axletree seating and lubricate. |
| 9 | There is jut before sealing and drape after sealing. | The speed of different straps is different, and the carton is not at the proper place when pushing into the machine. | Adjust each transporting line's pull to be consistent so that the carton can be put at the correct place. |
| 10 | There is drape after sealing | the strain of adhesive tape is too large | decrease the strain of adhesive tape |



5 Circuit diagram (P.9)

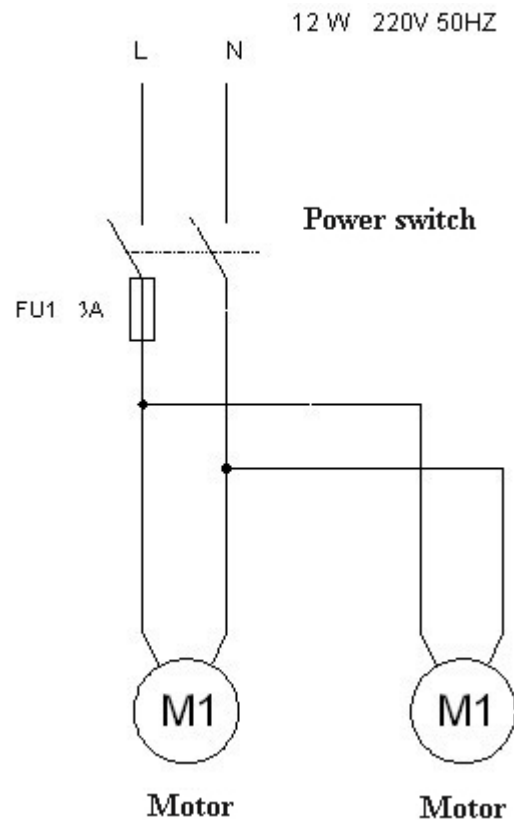

P.9





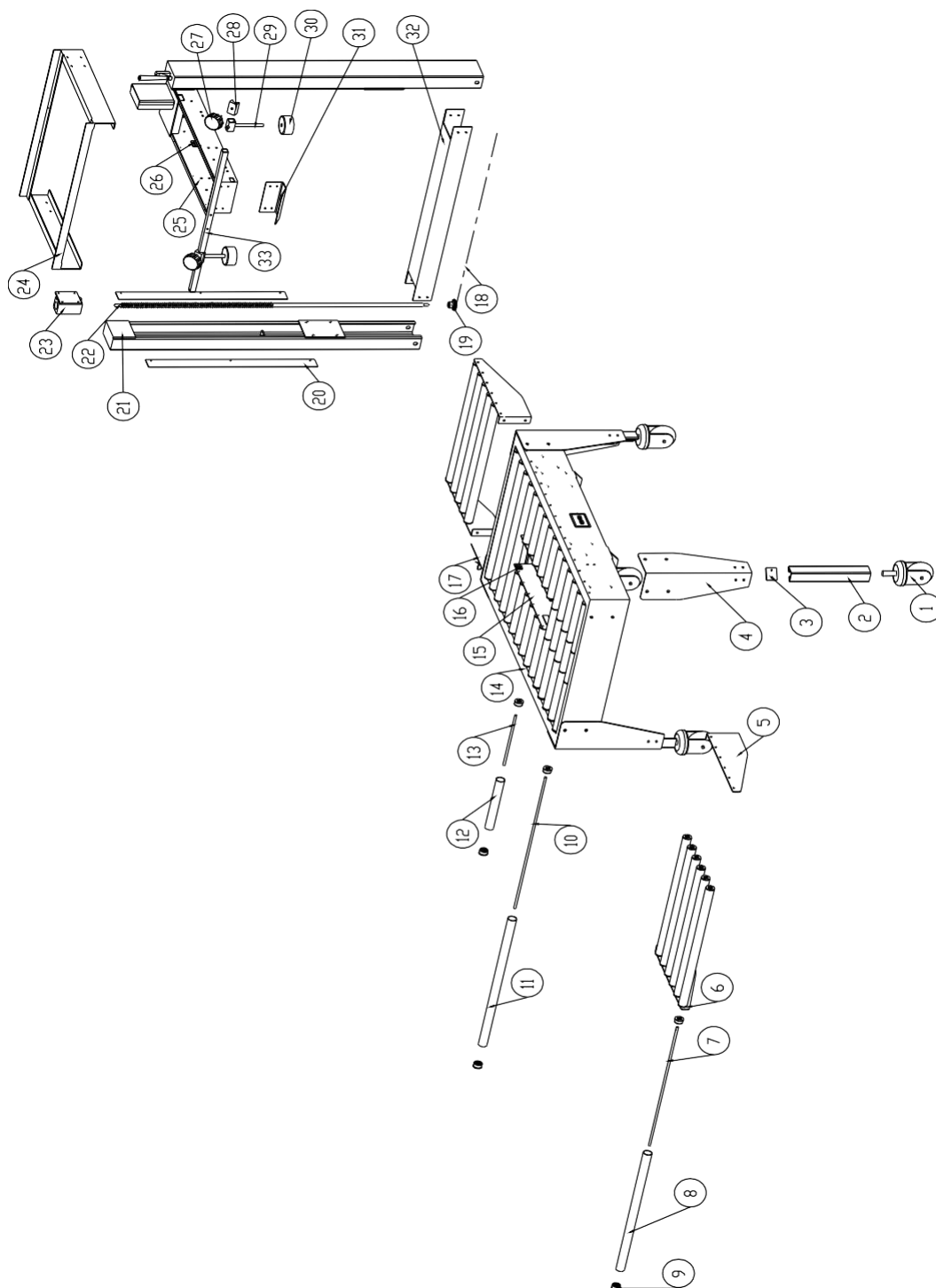







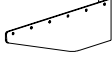

6 Exploded figure





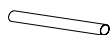







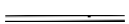
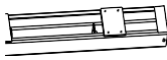

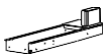

6.1 Exploded figure of the body (P.10, List 1)



P.10

Parts list 1

| ON | DRAW | DESCRIPTION | QT | MEMO |
|----|---|----------------------|----|------|
| 1 |  | Castors | 4 | |
| 2 |  | adjust undercarriage | 4 | |
| 3 |  | Solid Spruce | 4 | |
| 4 |  | undercarriage | 4 | |
| 5 |  | bracket | 2 | |
| 6 |  | bracket | 2 | |
| 7 |  | axle | 12 | |
| 8 |  | beam barrel | 12 | |
| 9 |  | bushing | 62 | |
| 10 |  | axle | 7 | |
| 11 |  | beam barrel | 7 | |
| 12 |  | beam barrel | 12 | |
| 13 |  | axle | 12 | |
| 14 |  | frame | 1 | |
| 15 |  | catch plate | 2 | |
| 16 |  | pin | 7 | |





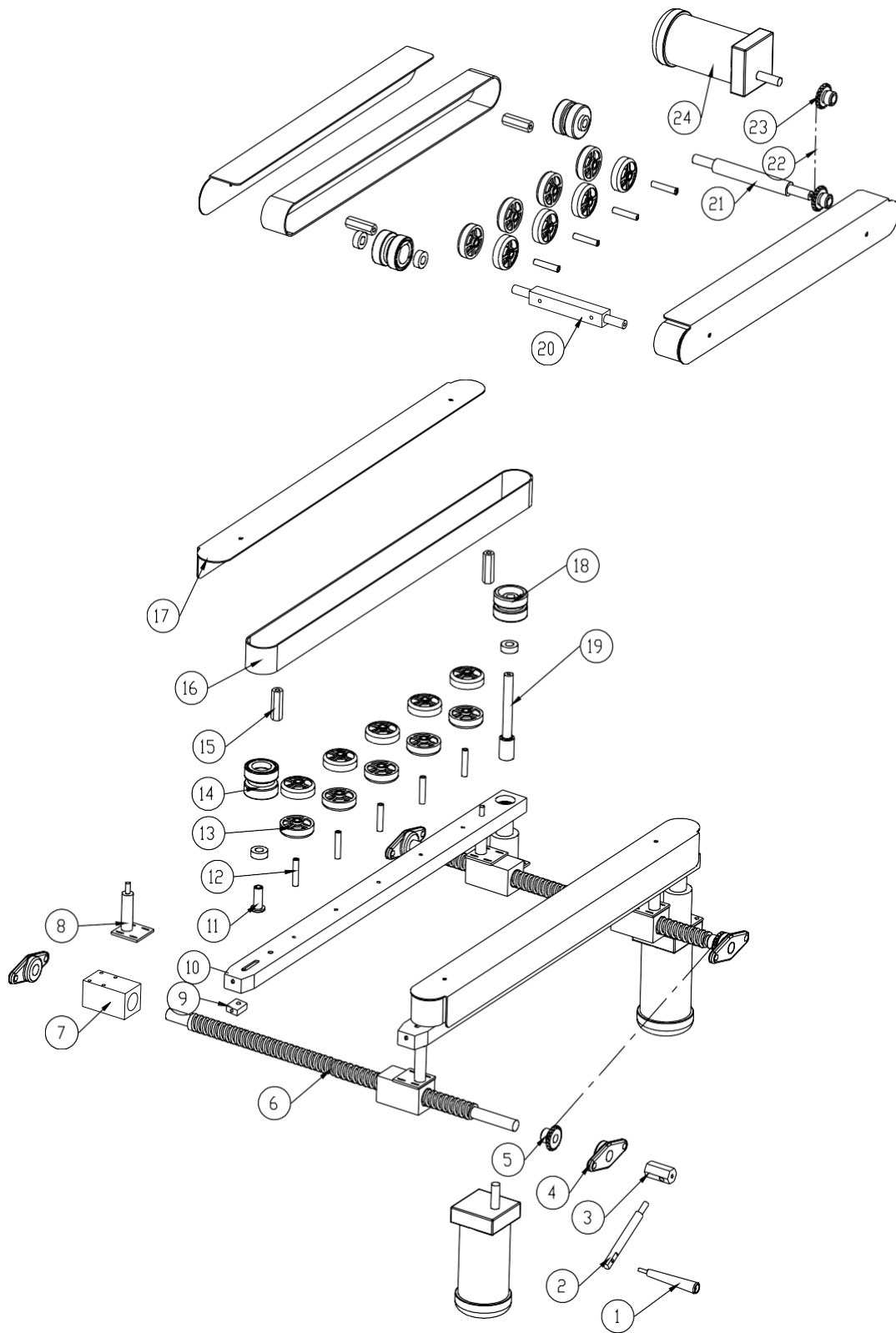





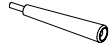

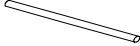

| | | | | |
|----|---|---------------------|---|--|
| 17 |  | chain | 1 | |
| 18 |  | chain wheel | 2 | |
| 19 |  | cover plate | 4 | |
| 20 |  | upright column | 2 | |
| 21 |  | axle | 2 | |
| 22 |  | bushing | 2 | |
| 23 |  | bracket | 1 | |
| 24 |  | bracket | 4 | |
| 25 |  | catch plate | 2 | |
| 26 |  | bracket | 1 | |
| 27 |  | handle | 2 | |
| 28 |  | lock block | 2 | |
| 39 |  | adjuster lever | 2 | |
| 30 |  | side pressure wheel | 2 | |
| 31 |  | guide plate | 1 | |
| 32 |  | cover | 1 | |
| 33 |  | adjuster lever | 1 | |



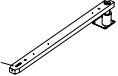





6.2 Exploded figure of driven belt system (P.11, List 2)

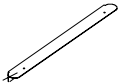

P.11

Parts list 2

| ON | DRAW | DESCRIPTION | QTY | MEMO |
|----|---|-----------------------|-----|------|
| 1 |  | handle | 2 | |
| 2 |  | handle setting shaft | 2 | |
| 3 |  | handle setting | 2 | |
| 4 |  | unit bearing assembly | 4 | |
| 5 |  | chain wheel | 2 | |
| 6 |  | screw rod | 2 | |
| 7 |  | Sliding base | 4 | |
| 8 |  | bracket | 4 | |
| 9 |  | adjusting slider | 2 | |
| 10 |  | bracket | 2 | |
| 11 |  | pin roll | 2 | |
| 12 |  | pin roll | 20 | |
| 13 |  | supporting roller | 40 | |
| 14 |  | driven wheel | 4 | |
| 15 |  | support bar | 8 | |
| 16 |  | Belt conveyor | 4 | |

| | | | | |
|----|--|--------------|---|--|
| 17 |  | cover plate | 4 | |
| 18 |  | drive wheel | 4 | |
| 19 |  | driving axle | 2 | |
| 20 |  | driven axle | 1 | |
| 21 |  | driving axle | 1 | |
| 22 |  | chain | 2 | |
| 23 |  | chain wheel | 2 | |
| 24 |  | Motor | 3 | |

6.3 Exploded diagram of tape dispenser (P.12, List 3)

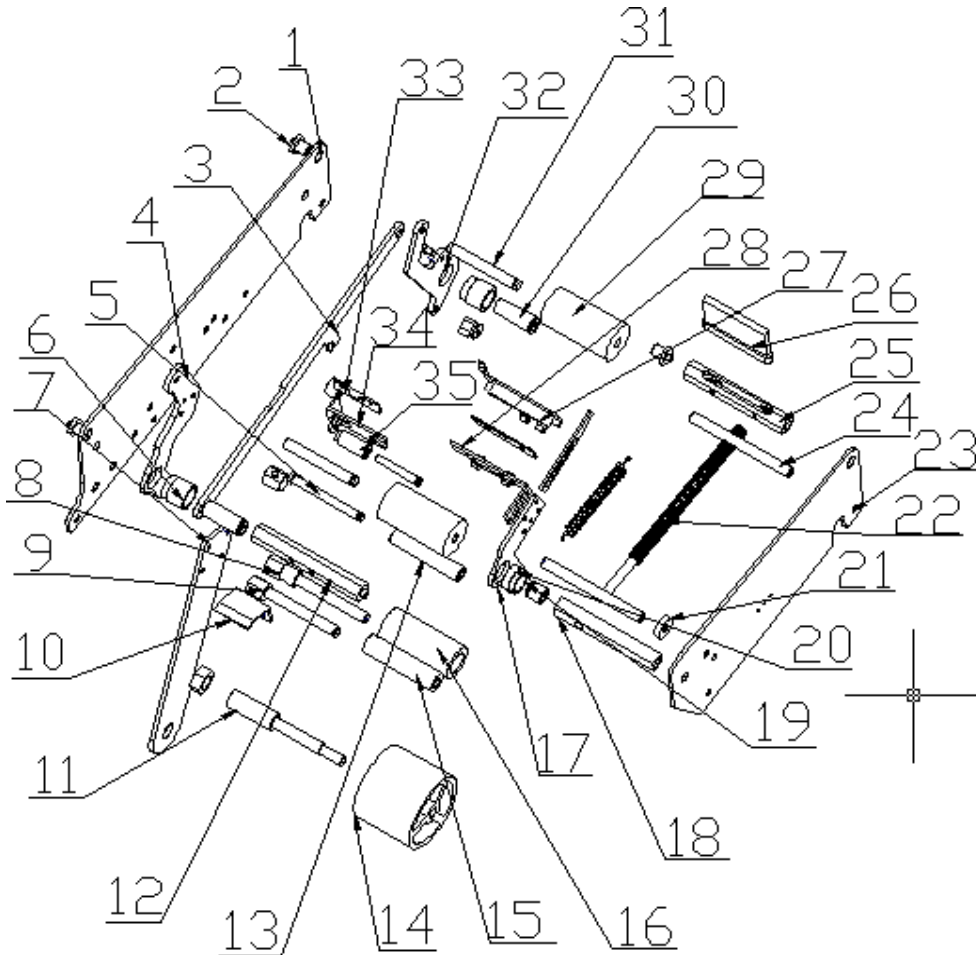

P.12

Parts list 3

| No. | Description | QTY | MEMO |
|-----|----------------------------|-----|------|
| 1 | Left panel | 1 | |
| 2 | Hexagon shaft | 1 | |
| 3 | Connection link | 1 | |
| 4 | Front swing | 1 | |
| 5 | Knurling guide roller axle | 1 | |
| 6 | Stationary axle sleeve | 2 | |

| | | | |
|----|--------------------------------------|---|--|
| 7 | Adhesive tape supporting arm | 1 | |
| 8 | Unidirectional guide roller axle | 1 | |
| 9 | PE roller axle | 1 | |
| 10 | Front guide board | 1 | |
| 11 | Adhesive tape holder stationary axle | 1 | |
| 12 | Front support axle | 1 | |
| 13 | Knurling guide roller | 1 | |
| 14 | Adhesive tape roller | 1 | |
| 15 | PE roller | 1 | |
| 16 | Unidirectional knurling roller | 1 | |
| 17 | Cutter holder wedding board | 1 | |
| 18 | Main spring lock shaft | 1 | |
| 19 | Cutter holder stationary axle | 1 | |
| 20 | Cutter holder stationary axle sleeve | 1 | |
| 21 | Baffle roller | 2 | |
| 22 | Main spring | 1 | |
| 23 | Right panel | 1 | |
| 24 | Panel lock axle | 2 | |
| 25 | Brush lock axle | 1 | |
| 26 | Brush | 1 | |
| 27 | Cutter cover | 1 | |
| 28 | Bracket | 1 | |
| 29 | Back glue roller | 1 | |
| 30 | Stationary axle | 2 | |
| 31 | Glue roller axle | 2 | |
| 32 | Rear swing | 1 | |
| 33 | Top-plate | 1 | |
| 34 | Adhesive supporting bracket | 1 | |
| 35 | U-shape axle sleeve | 1 | |