



Assembly Instructions

Riley *CURE* 245

RILEY 245 CONVEYOR DRYER



Riley Hopkins

Serial Number: _____

Date: ___/___/_____

(Record your machine's serial number and date of purchase for future reference)

IMPORTANT INSTRUCTIONS:

Read all these instructions before installing or using this equipment.

All wiring to this equipment must be connected to the electrical source in strict accordance with *National Electrical Code* (N.E.C.) and local codes having jurisdiction.

Do not use extension cords to power this equipment.

Before installing this equipment, the user must be aware of the safety requirements as specified by the *National Board of Fire Underwriters*.

/// CAUTION! ///

Puncture of the element face may result in a shock hazard.

This heater is hot when in use. To avoid burns, do not let bare skin touch hot surfaces. Keep combustible materials, such as furniture, pillows, bedding, papers, clothes, etc. away from the dryer.

Extreme caution is necessary when any dryer is used by or near children or invalids and whenever the heater is left operating and unattended.

Do not operate any heater after it malfunctions. Disconnect power at service panel and have heater inspected by a reputable electrician before reusing.

Do not use outdoors.

To disconnect the dryer, turn off the power to the dryer circuit at the main disconnect panel.

Do not insert or allow foreign objects to enter any ventilation opening as this may cause an electric shock or fire, or damage to the dryer.

A dryer has hot and arcing or sparking parts inside. Do not use it in areas where gasoline, paint, or flammable vapors or liquids are used or stored.

Use this dryer only as described in this manual. Any other use not recommended by the manufacturer may cause fire, electric shock, or injury to persons.

RETAIN THIS MANUAL FOR FUTURE REFERENCE

Please review all of these instructions prior to assembly.

The RileyCure 245 is packaged in five cartons for shipment.

Please make sure all pieces have been received before attempting assembly.



Tools Required:

- (x1) 1/2" wrench • (x1) Needle-nose pliers

What's in the box

Tag	ITEM	Qty.
RCJ17-D & RCJ17-T	DRIVE HALF OF CONVEYOR BED, WITH MOTOR	1
	TAKE UP HALF OF CONVEYOR BED	1
RCJ17-LK	CONVEYOR LEG ASSEMBLY	4
	CROSS BRACE	2
	BOLTS	22
RC14-301	CONVEYOR BELT	1
RCJ17-CP-240	CONTROL PANEL	1
RCJ17-3500C	ASSEMBLY INSTRUCTIONS	1
	HEATING CHAMBER	1
	4-INCH DUCT COLLAR	1
	4-INCH DUCT 2 FEET LONG	1
	END SHIELD	2

Accessories available:

- 90-409 Motor Cord (For Control Panel Assembly Opposite Side)

/// WARNING ///

DO NOT plug the equipment in (or apply power) until instructed to do so.

The RileyCure 245 requires a dedicated 240 Volt, 20 Amp circuit.

Any attempt to operate the RileyCure 245 without the cord/plug provided by the manufacturer will **void the warranty**.

Note: Portions of the assembly procedure require two people.

Unpack, identify, and inspect all parts. Report any missing or damaged items. Cover a 4' x 9' area on the floor with towels, cardboard, carpet, etc. to protect the painted parts from being scratched during assembly.

Conveyor Bed Assembly:

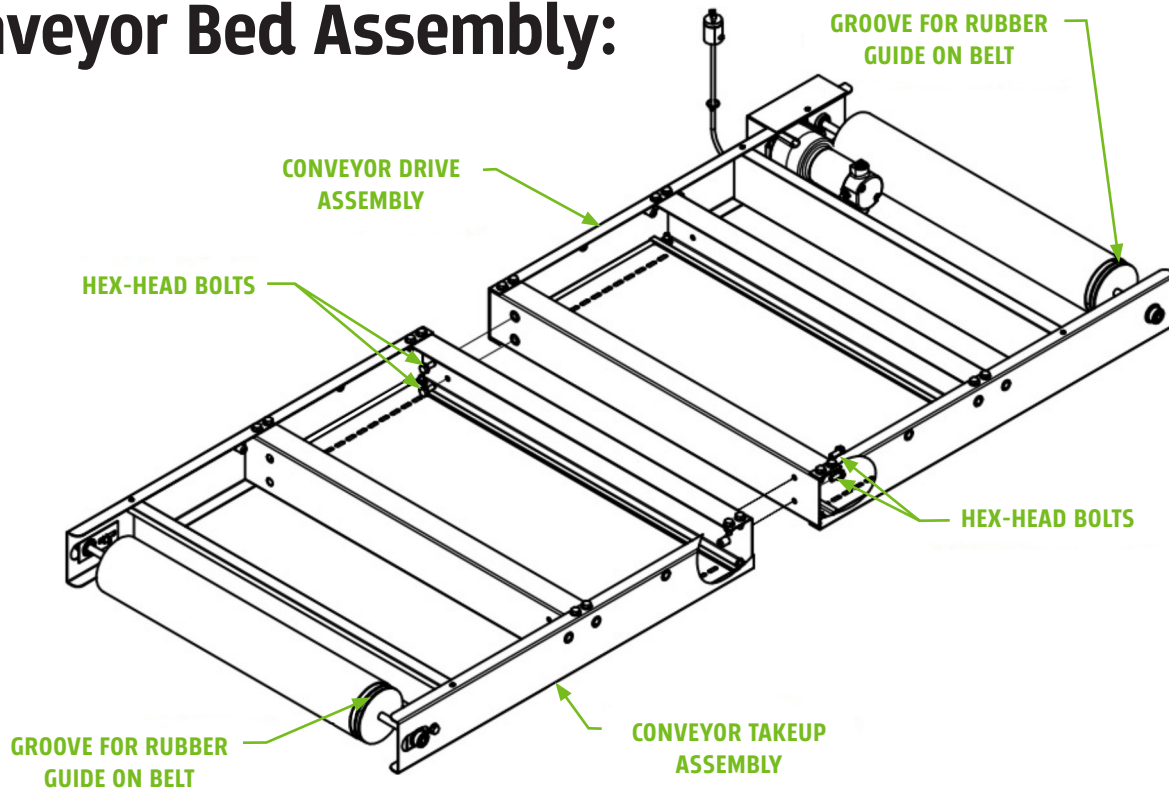

FIGURE 1

1. Place the Conveyor Drive Assembly on the covered floor (See **Figure 1**).
2. Butt the Conveyor Take-Up Assembly to the Drive Assembly. Be sure that the groove on each roller drum is on the same side of the bed.
3. Bolt the bed assembly together using (4x) Hex-Head Bolts (*found in RC21-LK carton*).

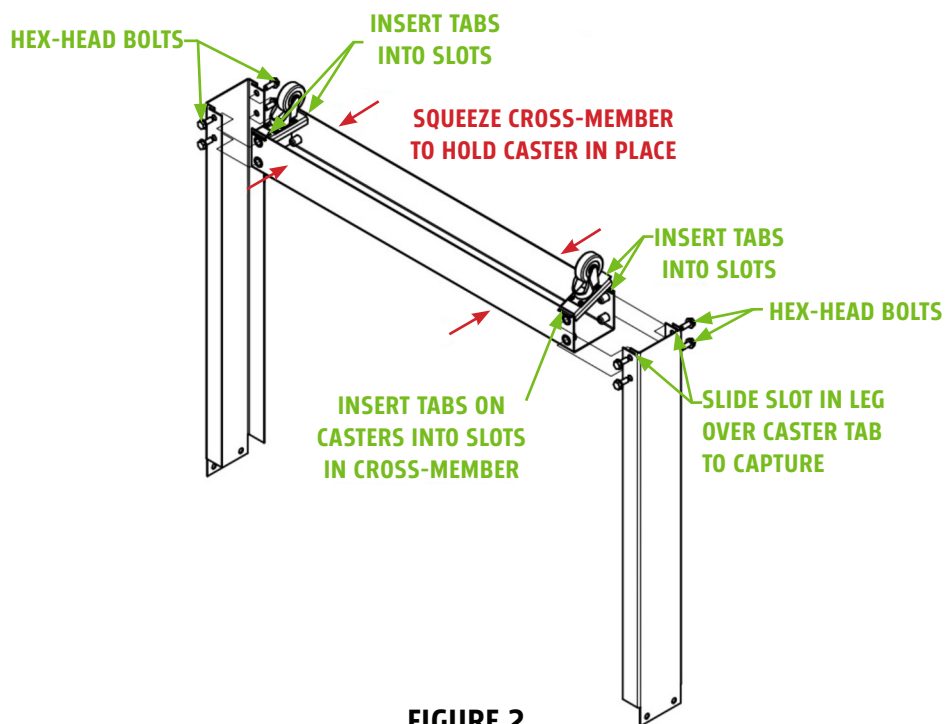

FIGURE 2

4. Insert the Tabs on the Caster Assembly into the slots on the Leg Cross Brace, then squeeze the Cross Brace to hold the Caster in place (See **Figure 2**).
5. Slide the Leg over the end of the Leg Cross Brace seating the slot in the Leg to capture the Tab on the Caster.
6. Align the thru-holes with the insert nuts and install the Hex-Head Bolts.
7. Repeat for the four Caster Assemblies, completing the two Leg Assemblies (See **Figure 2**).

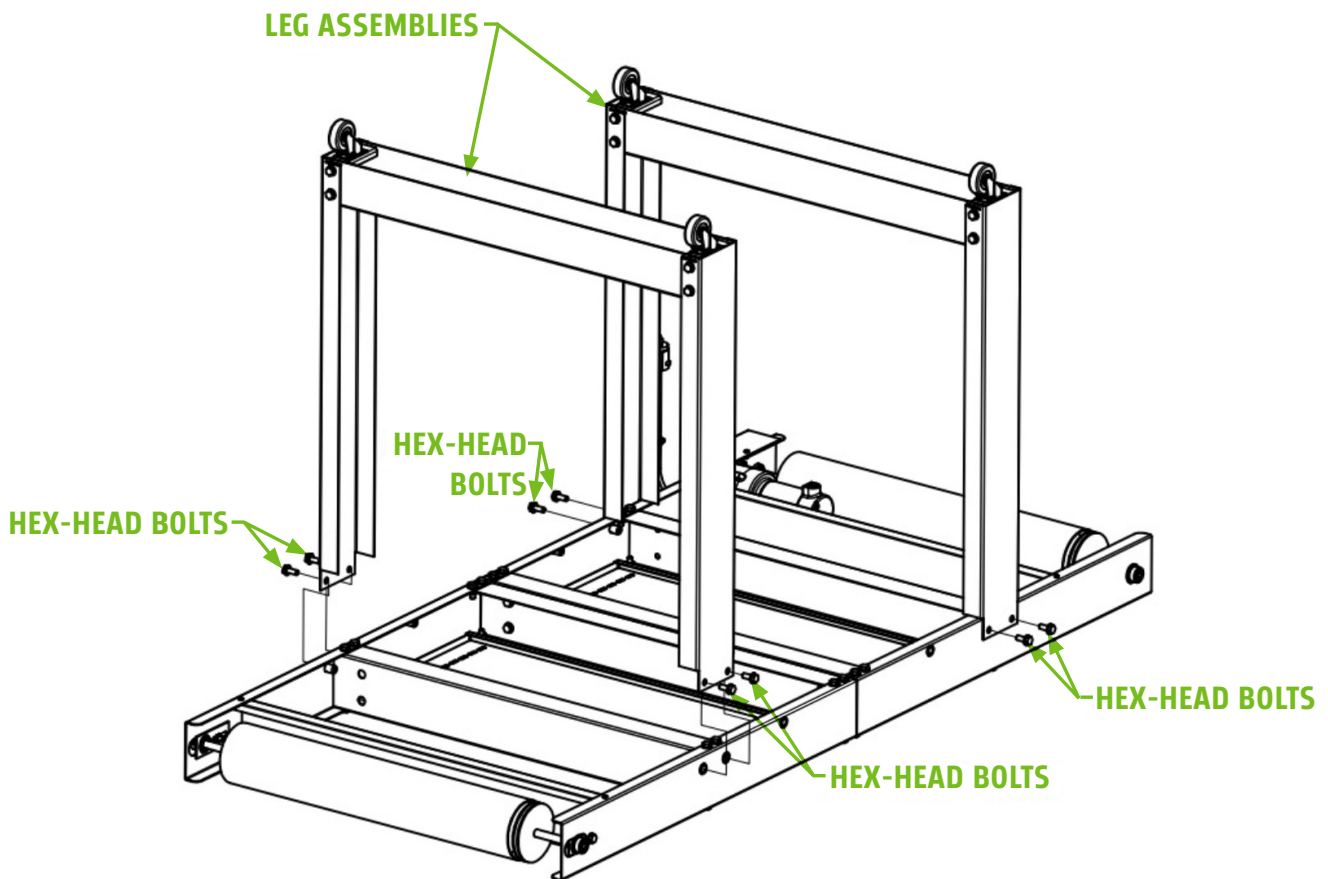

FIGURE 3

8. Place the Leg Assemblies over the Conveyor, aligning the thru-holes of the Leg Assemblies with the insert nuts of the Conveyor.
9. Install the eight Hex-Head Bolts (See **Figure 3**).
10. Tighten all Bolts.
11. Using two people, turn the conveyor bed over onto its casters.

Conveyor Belt Installation:

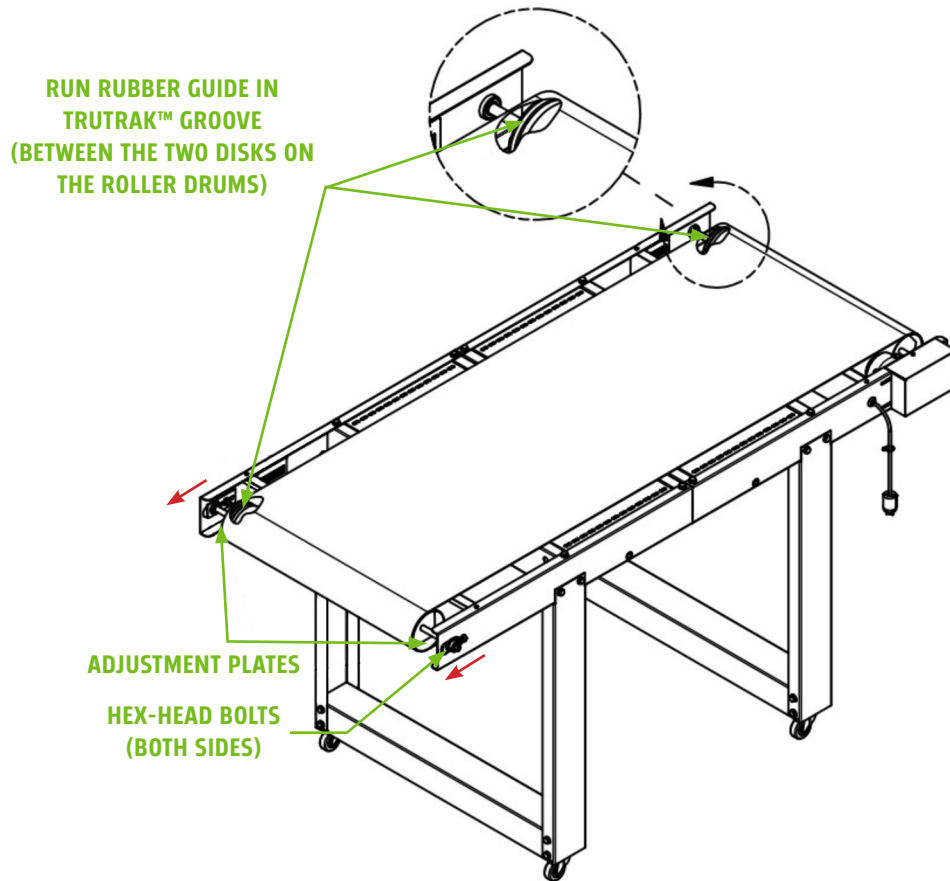

FIGURE 4

1. Determine the side of the belt that will convey the product. A rubber guide is stitched onto one edge of the belt. This guide is designed to ride in the *TruTrak™* roller drum grooves to provide hassle-free tracking (See **Figure 4**).
2. Carefully remove the splice pin from the inside teeth of the splice connector by pulling gently with needle-nose pliers if needed. **DO NOT BEND**; this pin will be reinserted later.
3. Lay the belt on the conveyor bed aligning the edge guide with the roller drum grooves.
4. Pull the ends of the belt together meshing the teeth of the splice while a second person reinserts the splice pin (removed earlier) into the channel formed by the interlocked metal teeth. It may be easier to rotate the belt so that the splice is on top of the conveyor bed before inserting the pin. Using needle-nose pliers, fully insert the pin until it is centered.
5. Adjust belt tension: Loosen (2x) hex bolts at Take Up Roller (See **Figure 4**). Pull roller at groove end till you have sag of 1 – 1.5 inches below the cross-members as the belt travels under the conveyor bed. Over-tightening the belt can lessen the lifetime of the conveyor belt. Tighten the hex bolt.
6. Adjust opposite end of the roller to the same location and tighten hex bolt.

Control Panel Installation:

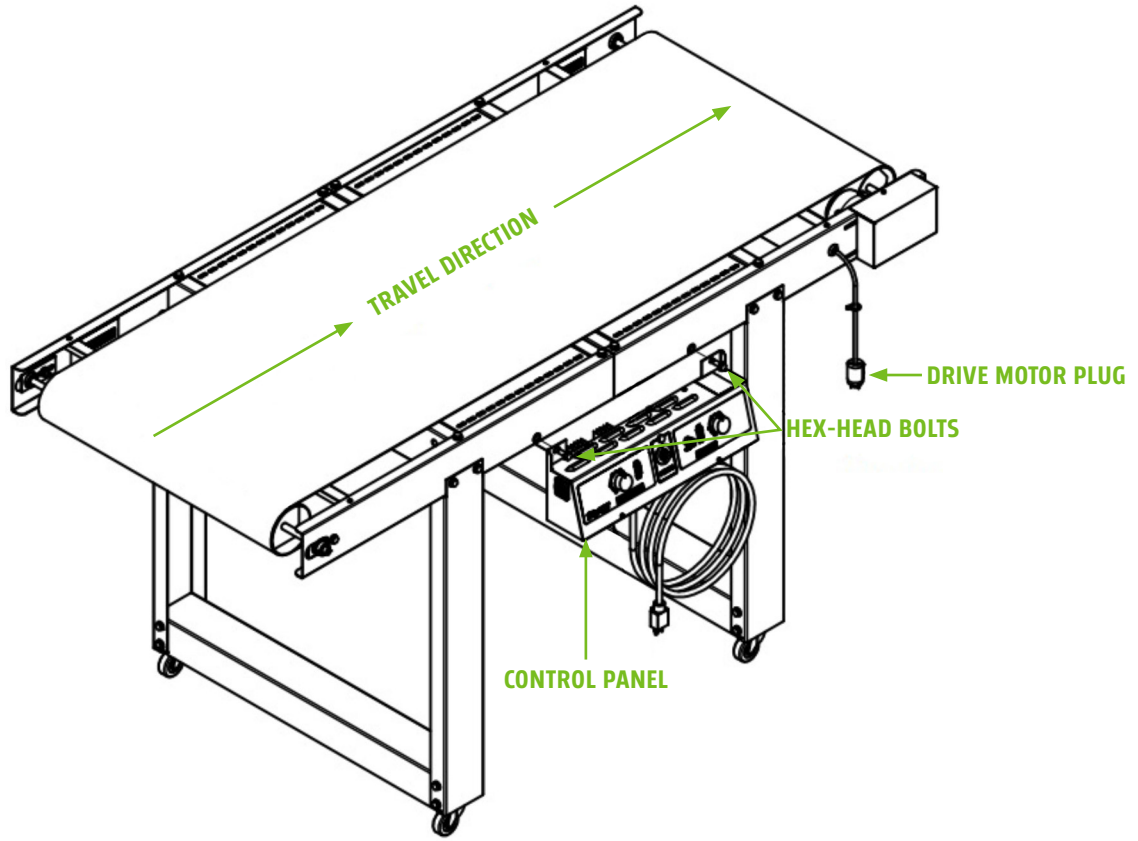

FIGURE 5

1. Two Hex-Head Bolts fasten the Control Panel to the Conveyor Assembly (See **Figure 5**).
2. Insert drive motor plug into drive motor receptacle. Twist plug to lock in place (See **Figure 6**).

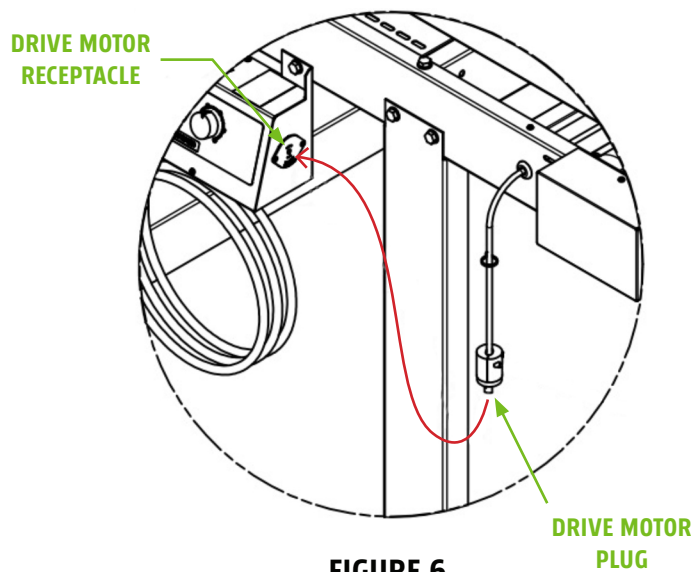

FIGURE 6

Attaching Heating Chamber:

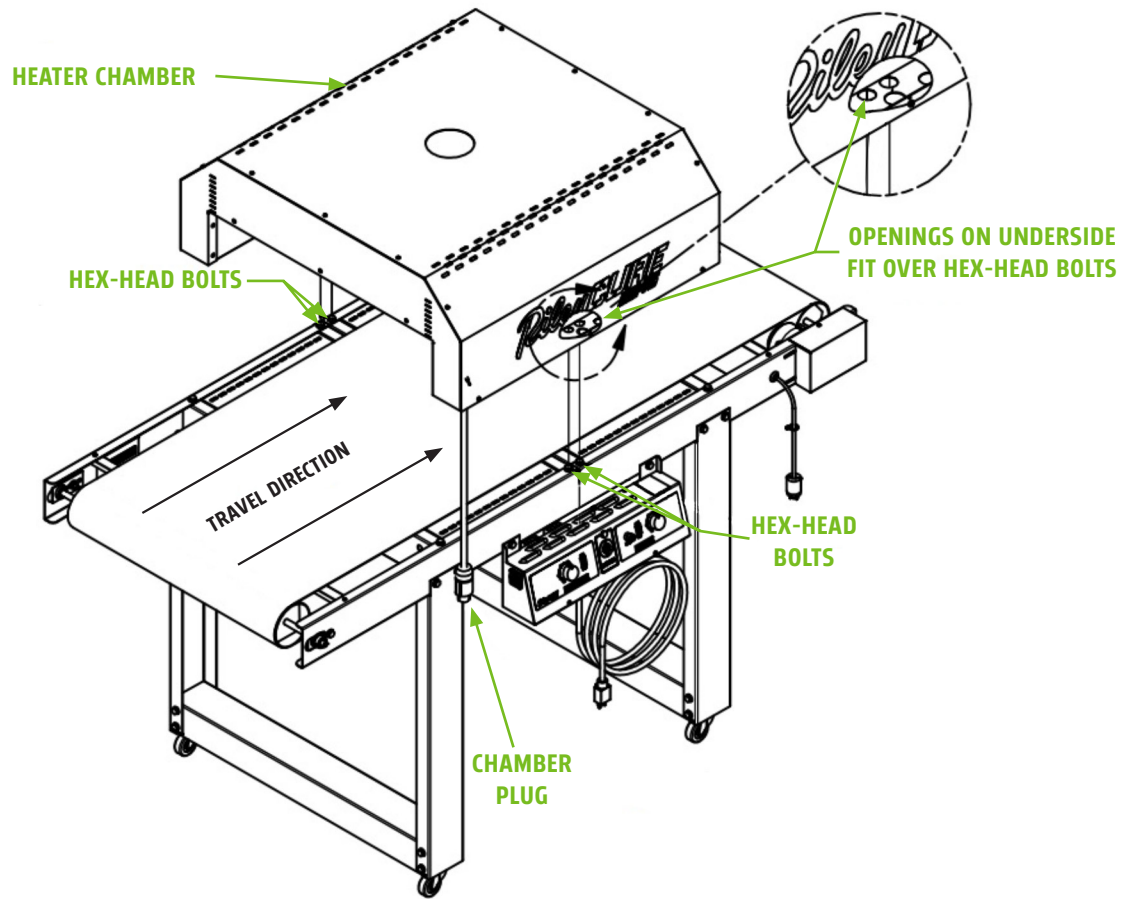

FIGURE 7

1. Using two people, set the chamber onto the conveyor bed (See **Figure 7**).
The Heating Chamber Cord must be on the same side of the Conveyor Bed as the Control Panel.
2. The Heating Chamber has openings on the underside rails that fit over the hex-head bolts (See Magnified View, **Figure 7**). The chamber should rest flatly on the conveyor bed.
3. Insert the Duct Start Collar into the hole in the top of the Heating Chamber (See **Figure 8**). Once in position, bend the tabs at the base of the collar outward to secure it in place. Place the two-foot section of 4" diameter Duct onto the Duct Start Collar.
4. Place End Shields at the desired height on the entrance and exit of the Heating Chamber. Plug the Heating Chamber cord into the receptacle on the Control Panel (See Magnified View, **Figure 8**).

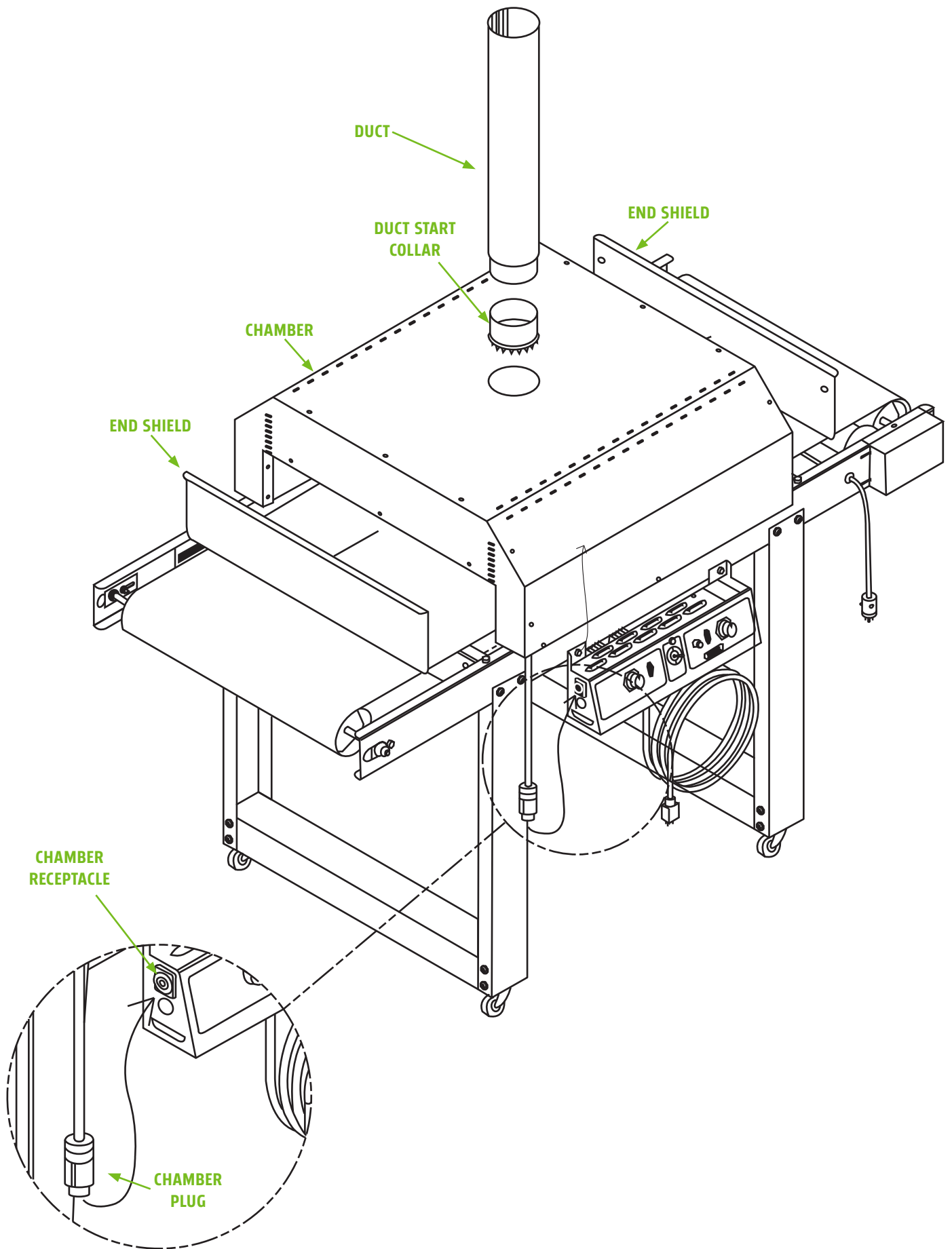

FIGURE 8

Control Panel Installation Opposite Side:

(90-409 Extension Cord Sold Separately)

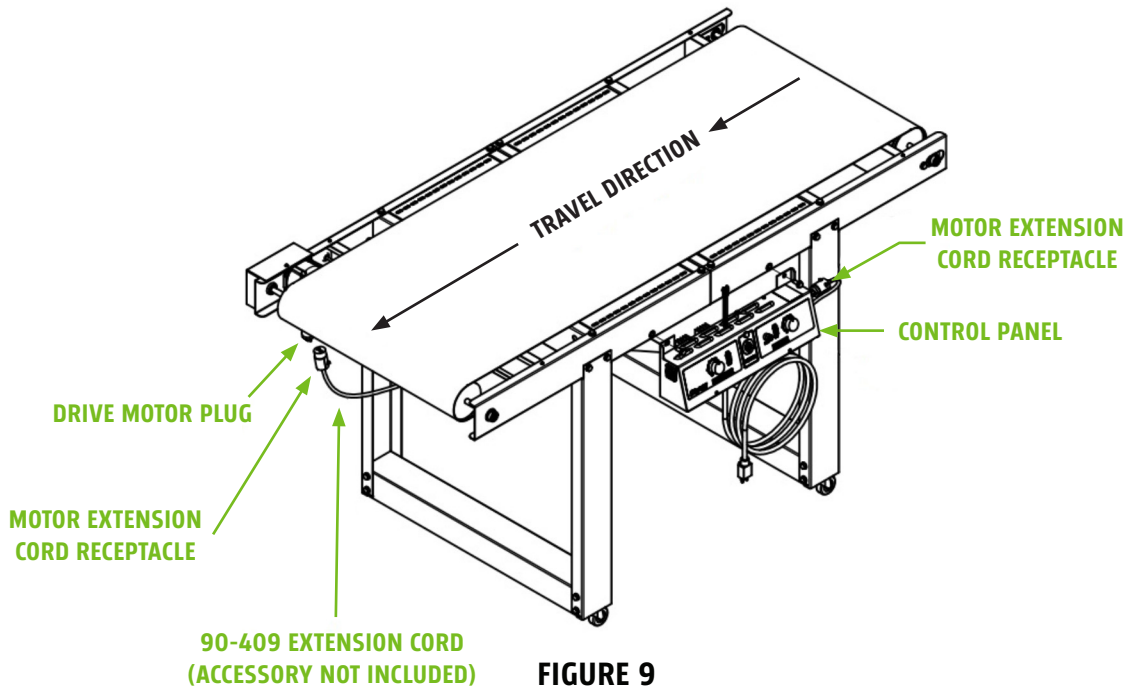

FIGURE 9

1. Use two Hex-Head Bolts to fasten the Control Panel to the Conveyor Assembly (See **Figure 9**).
2. Insert Drive Motor Plug into Motor Extension Cord Receptacle. Twist plug to lock in place (See **Figure 9**). Insert Motor Extension Cord Plug into Drive Motor Receptacle. Twist plug to lock in place (See **Figure 10**).

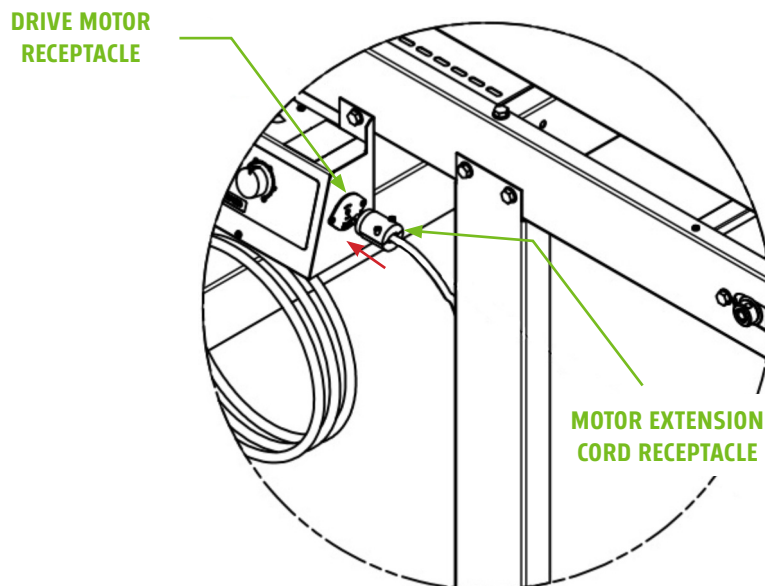

FIGURE 10

Attaching Heating Chamber Opposite Side:

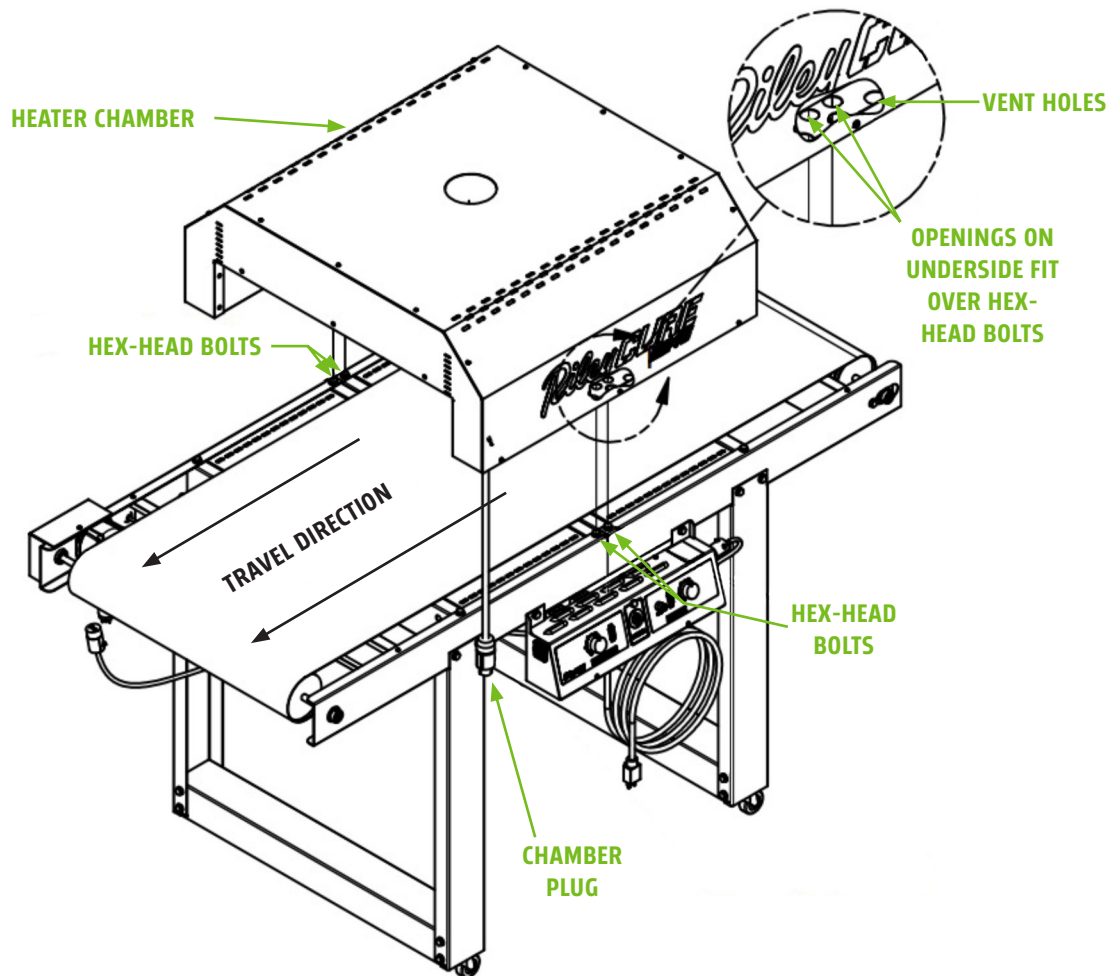

FIGURE 11

1. Using two people, set the Chamber onto the conveyor bed (See **Figure 11**). The Heating Chamber Cord must be on the same side of the Conveyor Bed as the Control Panel.
2. The Heating Chamber has openings on the underside rails that fit over the Hex-Head Bolts (See Magnified View, **Figure 11**). The chamber should rest flatly on the conveyor bed.
3. Insert the Duct Start Collar into the hole in the top of the Heating Chamber. Once in position (See Figure 12), bend the tabs at the base of the collar outward to secure it in place. Place the two-foot section of 4" diameter Duct onto the Duct Start Collar.
4. Place End Shields at the desired height on the entrance and exit of the Heating Chamber.
5. Plug the Heating Chamber cord into the receptacle on the Control Panel (See Magnified View, **Figure 8**) [Page 9].

Recommended Initial Start-Up Procedure:

1. **DO NOT** plug the equipment in (or apply power) until instructed to do so.

Note: The RileyCure 245 requires a dedicated 240 Volt, 20 Amp circuit. Any attempt to operate the RileyCure 245 without the cord/plug provided by the manufacturer will **void the warranty**.

2. Plug the Control Panel into a dedicated 240 Volt, 20 Amp circuit power source.
3. Turn the Main Power Switch to the ON position. The green indicator light will illuminate.
4. Turn Belt Speed to 5. Flip rocker switch for Belt Speed to ON position to start belt. Listen for any unusual noises. Check to see if the rubber edge guide is riding in the *TruTrak™* roller drum grooves.
5. Turn Heat Control to 5. Flip rocker switch for Heat Control to ON position.

Note: These are not production settings. They are intended for initial startup only.

/// CAUTION ///

DO NOT operate Heating Chamber unless the belt is moving. Heat will damage an idle belt.

6. Verify that the heating element functions. After about a minute of operation, briefly feel just inside both the entrance and exit ends of the chamber. The area should be warm.

/// CAUTION ///

The heating element is exposed inside the chamber and is operating at very high temperatures. Keep your hand close to the moving belt.

Note: Some smoke/vapor and odor may be noticed during initial start-up due to residual material from the manufacturing process burning off the elements.

7. Working temperature will be reached after a ten-minute warm-up.
 - Test articles may be run to determine the optimal production speed and heat setting for your environment and products.
 - Conveyor speed can be determined by placing a small item, like a coin, on the conveyor belt and recording the time it takes to travel through the chamber. (For curing plastisol inks on t-shirts, 30 seconds through the Heater Chamber is a good initial speed to begin your evaluation.)

Note: The speed and temperature of the unit may vary slightly with fluctuations in power/voltage servicing the equipment.

Process an item through the dryer. Evaluate the completed article according to your quality standards. If the equipment is being used for curing ink on garments, it's recommended wash the processed garment as the definitive test.

Control Panel Maintenance:

Performed at initial installation, 30 days after initial installation, and 120 days after initial installation.

1. Turn OFF the power serving the main control panel where it is connected to the building's electrical distribution system. Unplug the unit.

Note: Assure that appropriate "Lock-Out / Tag-Out" procedures are followed before conducting any of these activities.

2. After double-checking that the power is off, confirm that all electrical terminations inside of the main control panel are secure by checking the "tightness" of each termination screw (or wire nut as may be applicable) and then "tugging" on each conductor.

Routine Maintenance: Performed after the first week and every 100 hours of operation.

1. The belt should be replaced if it has any tears, voids, separations, fraying, or no longer rides in the roller drum groove due to excessive wear.
2. Belt tension: the belt will relax over time and tension may have to be adjusted by the instructions above.

Troubleshooting:

SYMPTOM	WHAT TO CHECK
No heat, belt not moving, & power light is off	INCOMING POWER, CORRECT VOLTAGE
	MAIN POWER SWITCH
	POWER CORD PLUGGED IN
No heat, belt moving, & power light is on	CHAMBER CORD PLUGGED INTO CONTROL PANEL
	HEAT CONTROL KNOB IS NOT TURNED UP
Oven temperature too low	HEAT CONTROL KNOB IS NOT TURNED UP
	INCORRECT POWER TO HEATER
Oven temperature too high	INCORRECT POWER TO HEATER
Temperature fluctuates	CURTAINS TOO HIGH
	ELIMINATE WIND OR DRAFT THROUGH HEATER
Belt stopped or is erratic	MOTOR POWER CORD PLUGGED IN, TWISTED & LOCKED INTO PLACE
	FUSE ON CONTROL PANEL
	SPROCKETS & CHAIN
	SPEED CONTROL KNOB TURNED DOWN
	BRUSHES IN MOTOR, CONTACT FOR REPLACEMENTS
Excessive motor noise	BRUSHES IN MOTOR, CONTACT FOR REPLACEMENTS

MANUFACTURER'S WARRANTY

All products are warranted against defects in workmanship at the time of shipment. The obligation under the above warranty shall be limited to the repair or replacement of any part or parts manufactured by the dryer manufacturer without charge F.O.B. factory that may prove defective within 12 months from the date of shipment, which is returned to the dryer manufacturer. The above warranties are the only warranties made with respect to the equipment. There is no implied warranty of merchantability or of fitness.

EXCLUSIONS: There is no warranty on parts not manufactured by the dryer manufacturer, other than the respective manufacturer's warranty if any. The warranty against defects shall not extend to damage caused by any of the following:

- Transport by carrier
- Corrosion
- Operation or use in a manner inconsistent with specifications and/or operating instructions
- Ordinary wear, accident, improper installation, or maintenance
- Alterations made to equipment in any way

The dryer manufacturer shall not be liable for losses or damages, including but not limited to incidental or consequential damages, suffered or incurred because the equipment proves to be defective either upon installation or during its operation or use. Shipment of defective parts to the dryer manufacturer and the return shipment of any repaired or replacement parts from the dryer manufacturer shall be at the purchaser's/user's expense.

Riley Hopkins[®]