



Assembly Instructions

Riley Hopkins[®]
250

4-COLOR, 1-STATION MICRO





Tools Required:

- Two 9/16" wrenches
- One Phillipps screwdriver

What's in the box

Tag	ITEM	Qty.
1	MAIN PRESS CORE ASSEMBLY	1 PER UNIT
2	MICRO PRINT HEAD ASSEMBLY WITH SCREEN CLAMP	4 PER UNIT
3	MOUNTING FEET	2 PER UNIT
4	16" X 16" MDF PLATENS WITH NECK	1 PER UNIT
5	HARDWARE KIT	1 PER UNIT

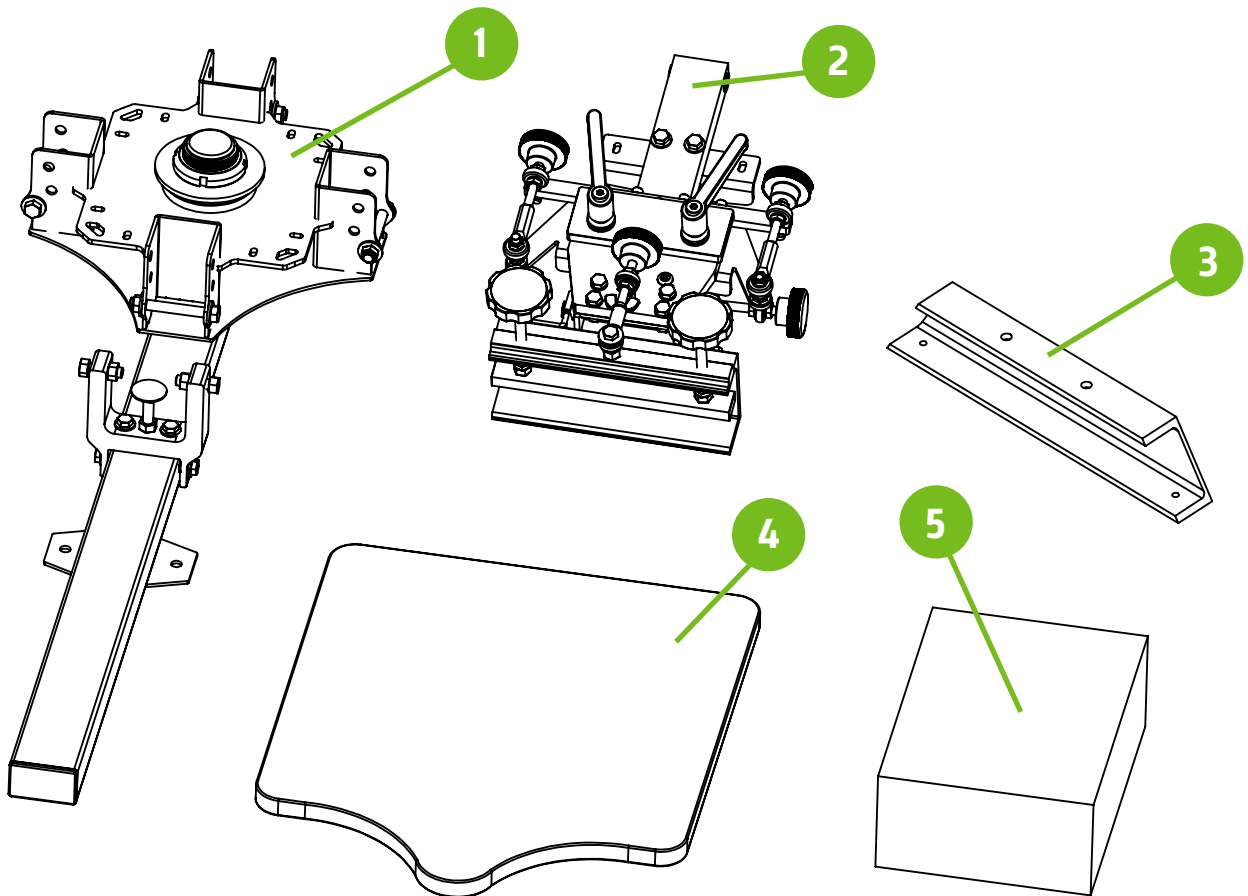

PRCO-RH250MTGHDW

RILEY 250 MOUNTING FEET HARDWARE

Tag	NAME/ID	DESCRIPTION	Qty.
1	PRHD-HC3/8NC1GR5ZC	3/8-16 X 1 HEX CAP SCREW	4
2	PRHD-WA3/8USSPFC9ZY	3/8 PFC9 USS FLAT WASHER-YELLOW	8
3	PRHD-LNYN3/8NCGR5ZC	3/8-16 LOWPRO NYLOC ZINC	4
4	PRCO-JR41MTGHDWKIT	MOUNTING HARDWARE PACK PERFORATED BAG (QTY. 4 SCREWS)	1

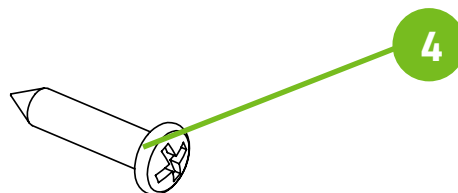
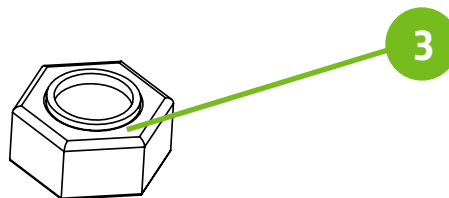
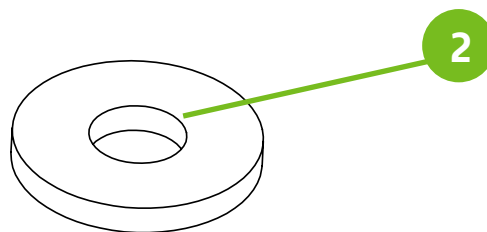
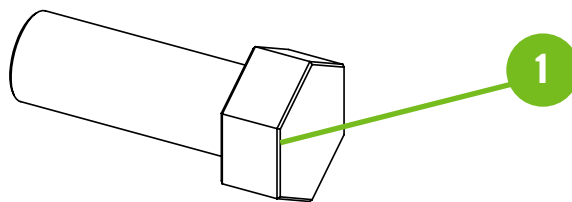

PRCO-RH250STOPHDW

RILEY 150 SCREEN CLAMP HARDWARE KIT

Tag	NAME/ID	DESCRIPTION	Qty.
1	PRSA-SPRINGKIT	MESH COVERED SPRING	8
2	PRCO-BMPRBLTCVRBLU	PRINT HEAD RUBBER BUMP STOP	4
3	PRHD-HC3/8NF3GR5ZC	3/8-24 X 3" HEX CAP SCREW GRADE 5 ZINC	4
4	PRHD-LNYN3/8NFGR5ZC	3/8-24 LOWPRO NYLOC NUT	4
5	PRHD-WA3/8SAE-SS	3/8 FLAT WASHER	8
6	PRCO-9/16ENDWRENCH	9/16" END WRENCH (OFF-CONTACT ADJUSTMENT)	1

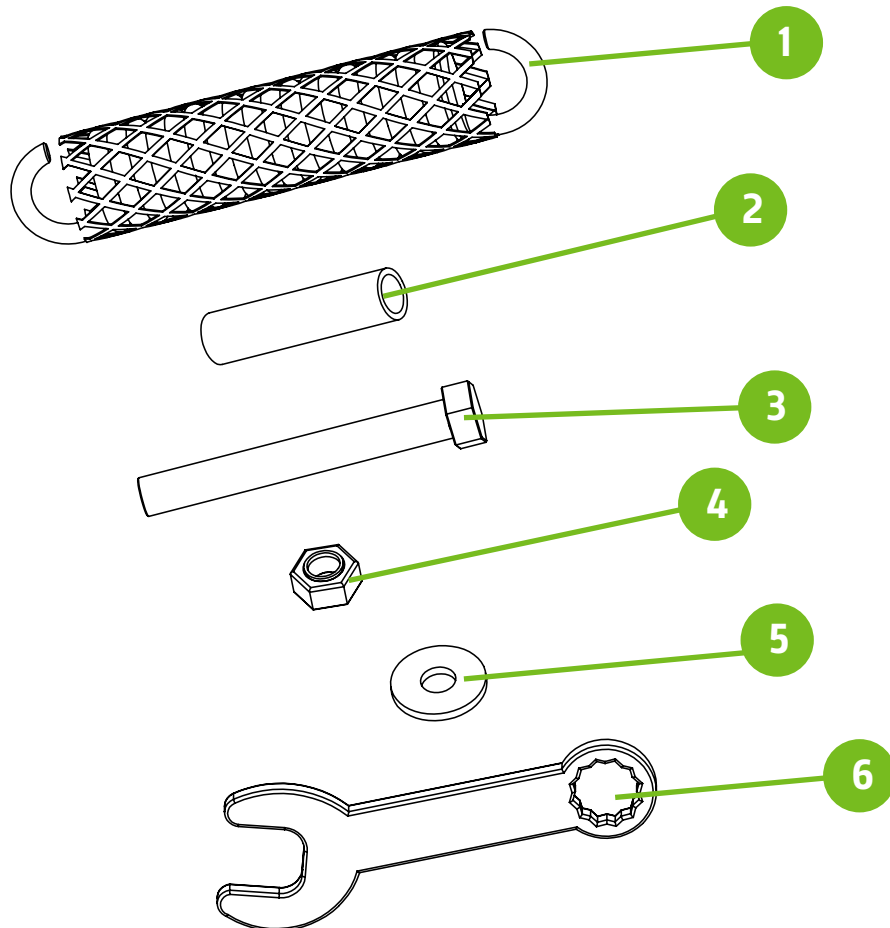

PRCO-RH250HNGHDW

RILEY 250 PRINT HEAD HINGE HARDWARE KIT

Tag	NAME/ID	DESCRIPTION	Qty.
1	PRHD-HC3/8NF3GR5ZC	3/8-24 X 3" HEX CAP SCREW GRADE 5 ZINC	4
2	PRHD-WA3/8SAE-SS	3/8 FLAT WASHER	8
3	PRHD-LNYN3/8NFGR5ZC	3/8-24 LOW PRO NYLOC NUT	4

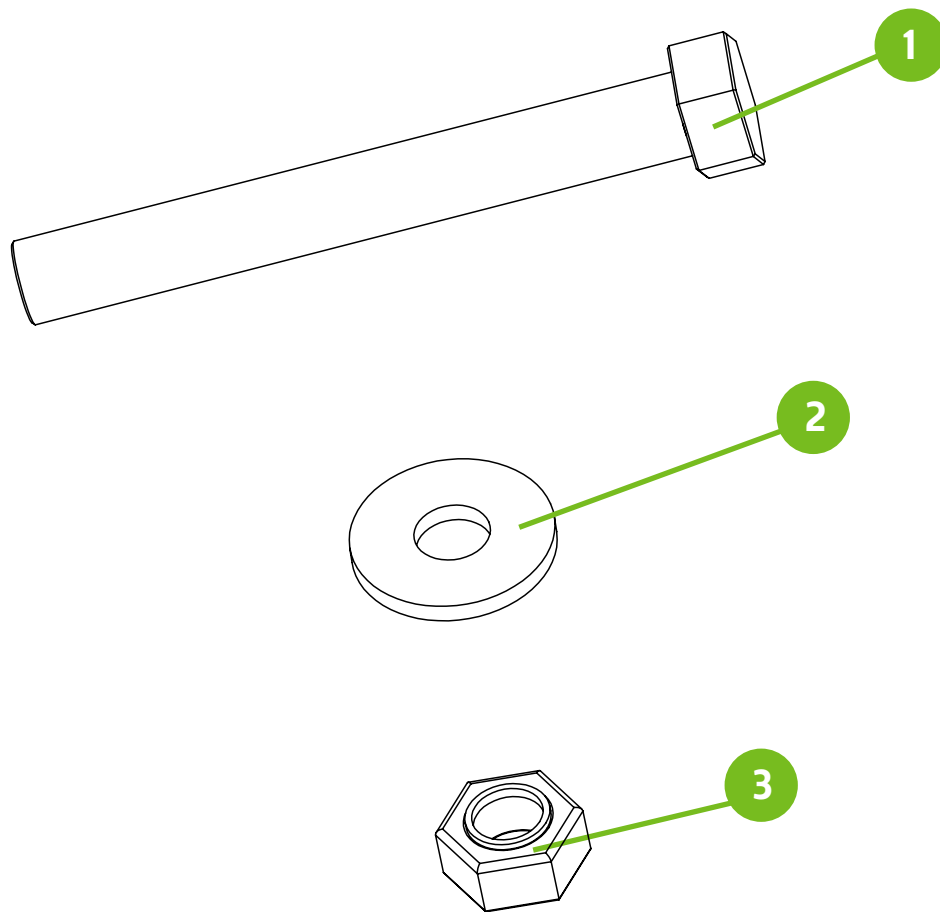

Step 1

Install the Mounting feet (4) to the main press core with the supplied hardware. Two 9/16" wrenches are required for this step.

Note: Refer to Page 2 for hardware detail.

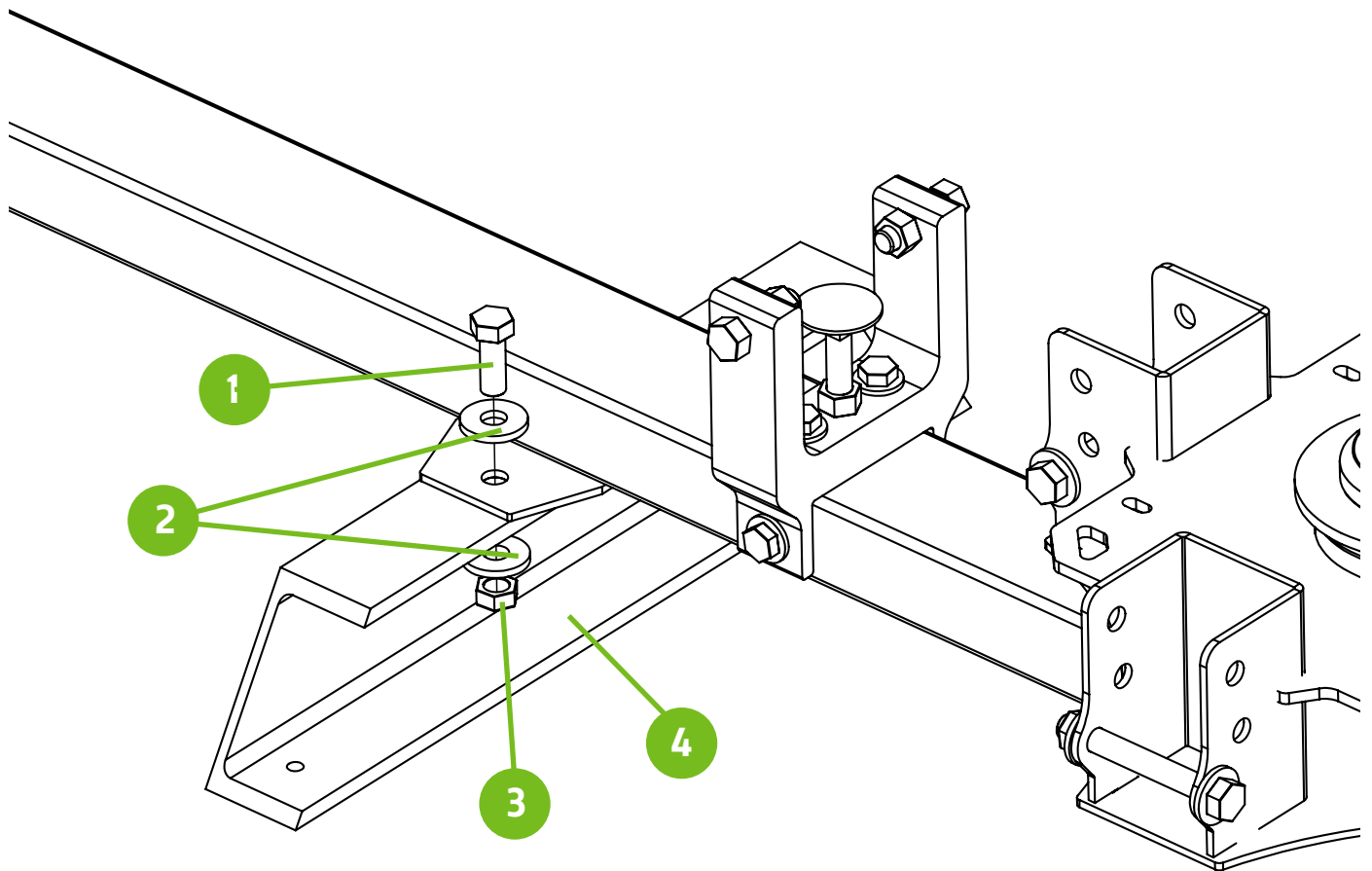

Step 2

Install the Print head assemblies with the supplied hardware. Two 9/16" wrenches are required for this step. Repeat this step for the remaining print head assemblies.

Note: Refer to Page 4 for hardware detail.

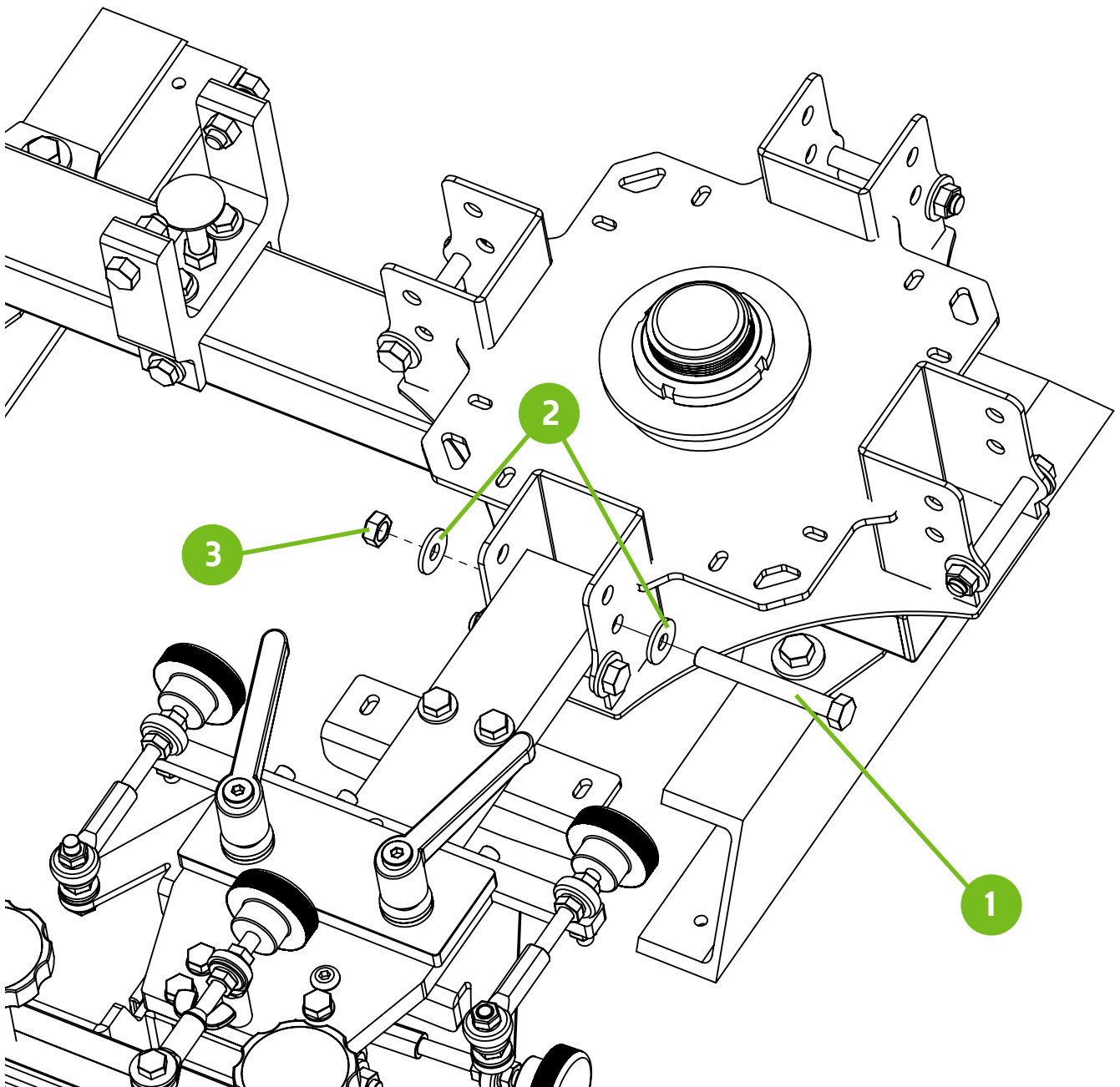

Step 3 **/// CAUTION! ///**

Install the spring assemblies with the hooks facing upward. Lower the Print head assemblies until they rest on the lower stop bolt. Repeat this step for the remaining print head assemblies.

Note: Refer to Page 3 for hardware detail.

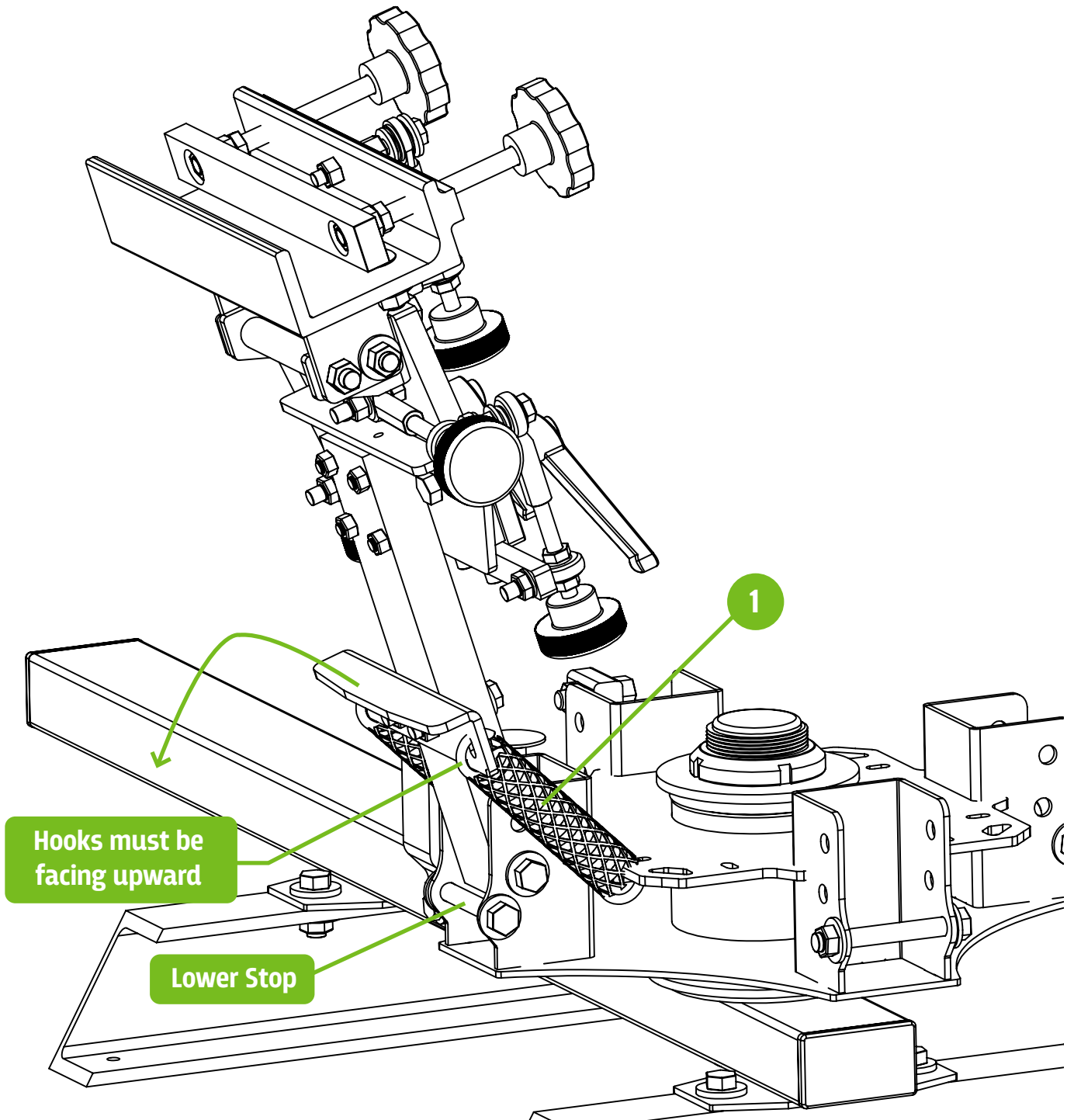

Step 4

Install the upper stop bolts and rubber sleeves. Two 9/16" wrenches are required for this step. **DO NOT OVERTIGHTEN THE BOLTS.** This will cause resistance in the print head hinge point. Repeat this step for the remaining print head assemblies.

Note: Refer to Page 3 for hardware detail.

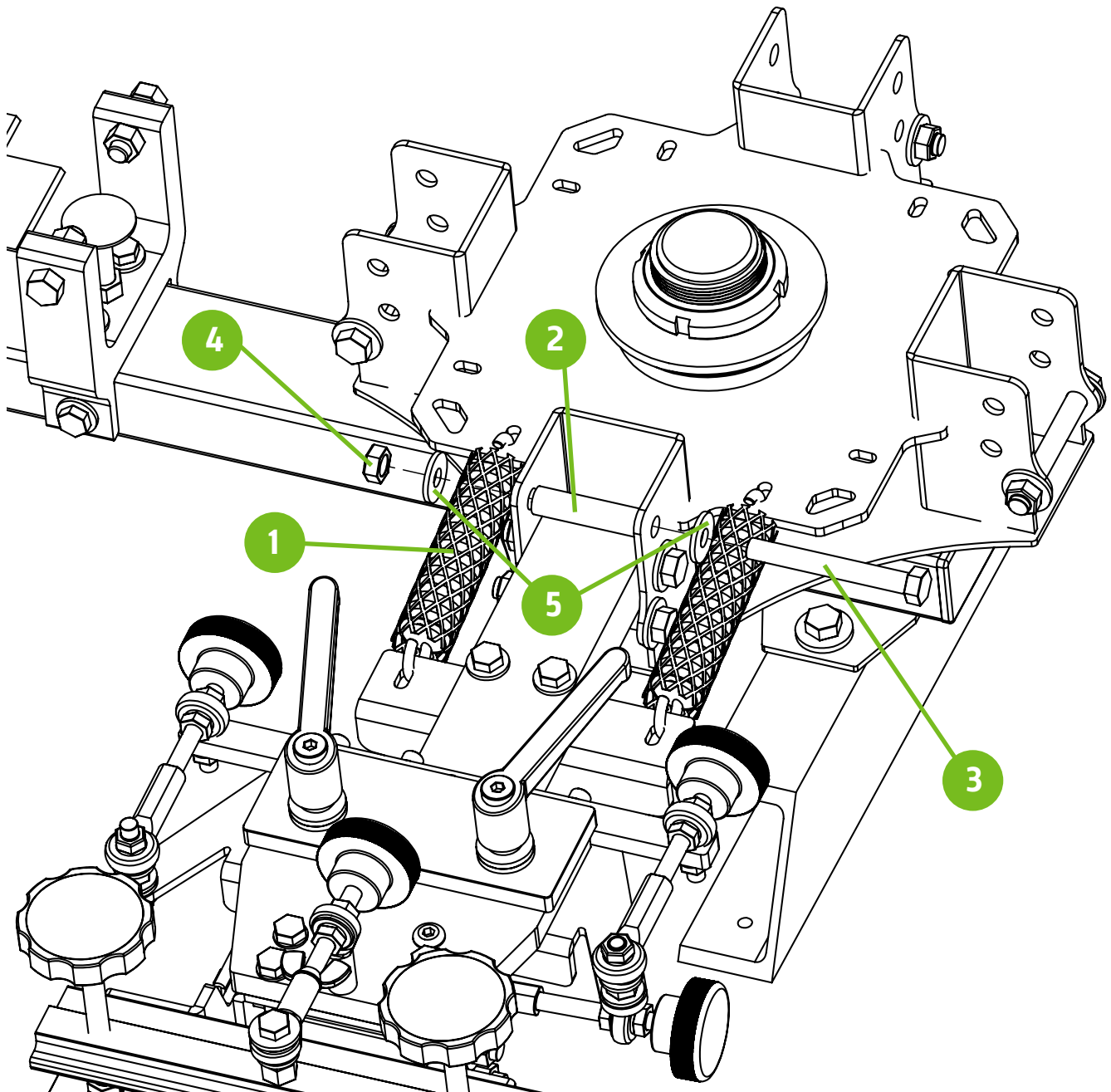

Step 5

Mount the press base feet (2) to a sturdy tabletop with supplied mounting screws (1). Press is shown mounted on a Riley Hopkins 1-station press cart (sold separately). A Phillips screwdriver is required for this step.

Note: Refer to Page 2 for hardware detail.

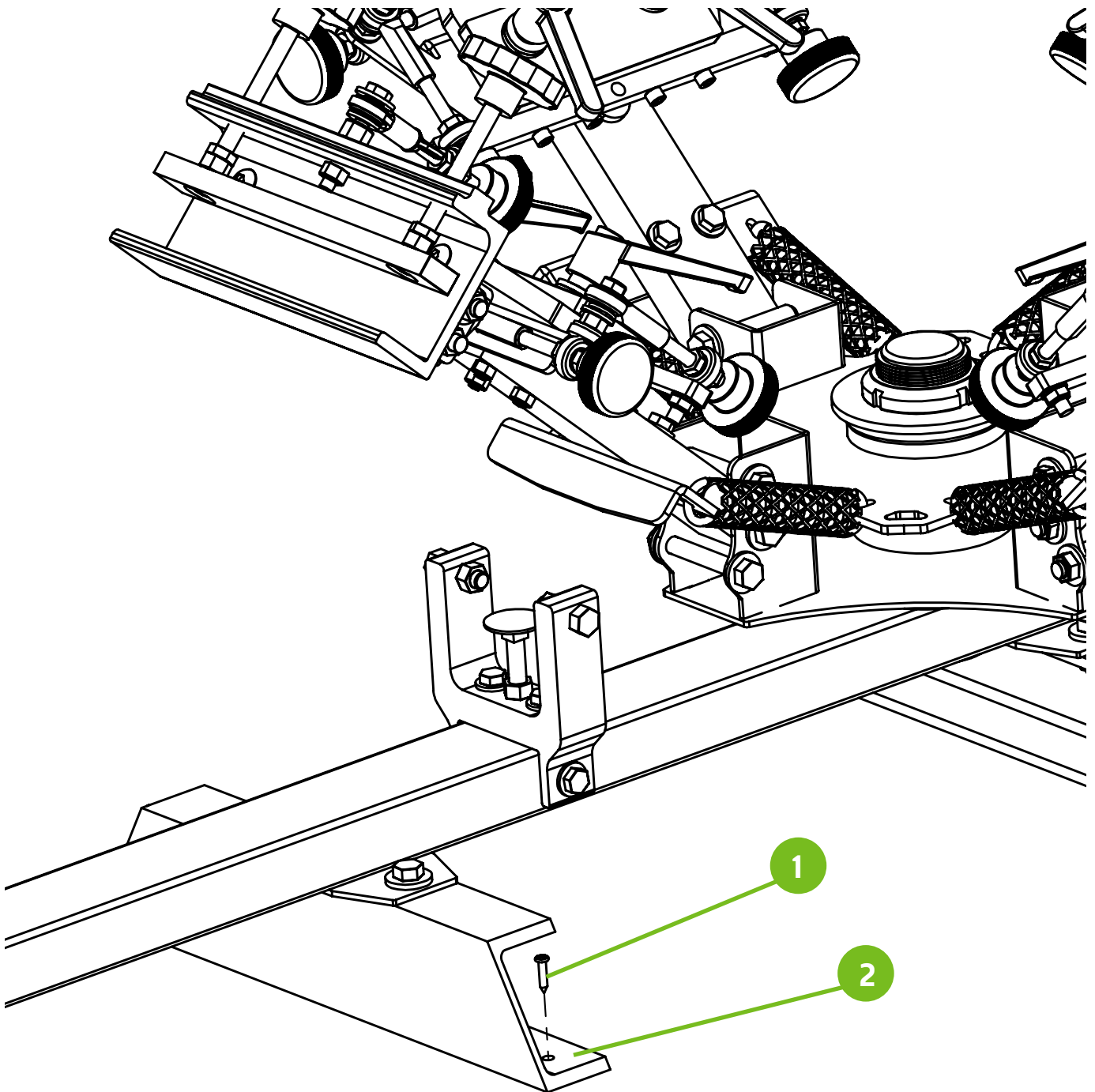

Step 6

Install the platen assembly (1) onto the tubular arm of the press. When platen is in desired location, first lock down the side knob (2). Lastly, tighten down the lower locking knobs (3). The platen can be adjusted front-to-back to help position the image onto the desired location of the substrate.

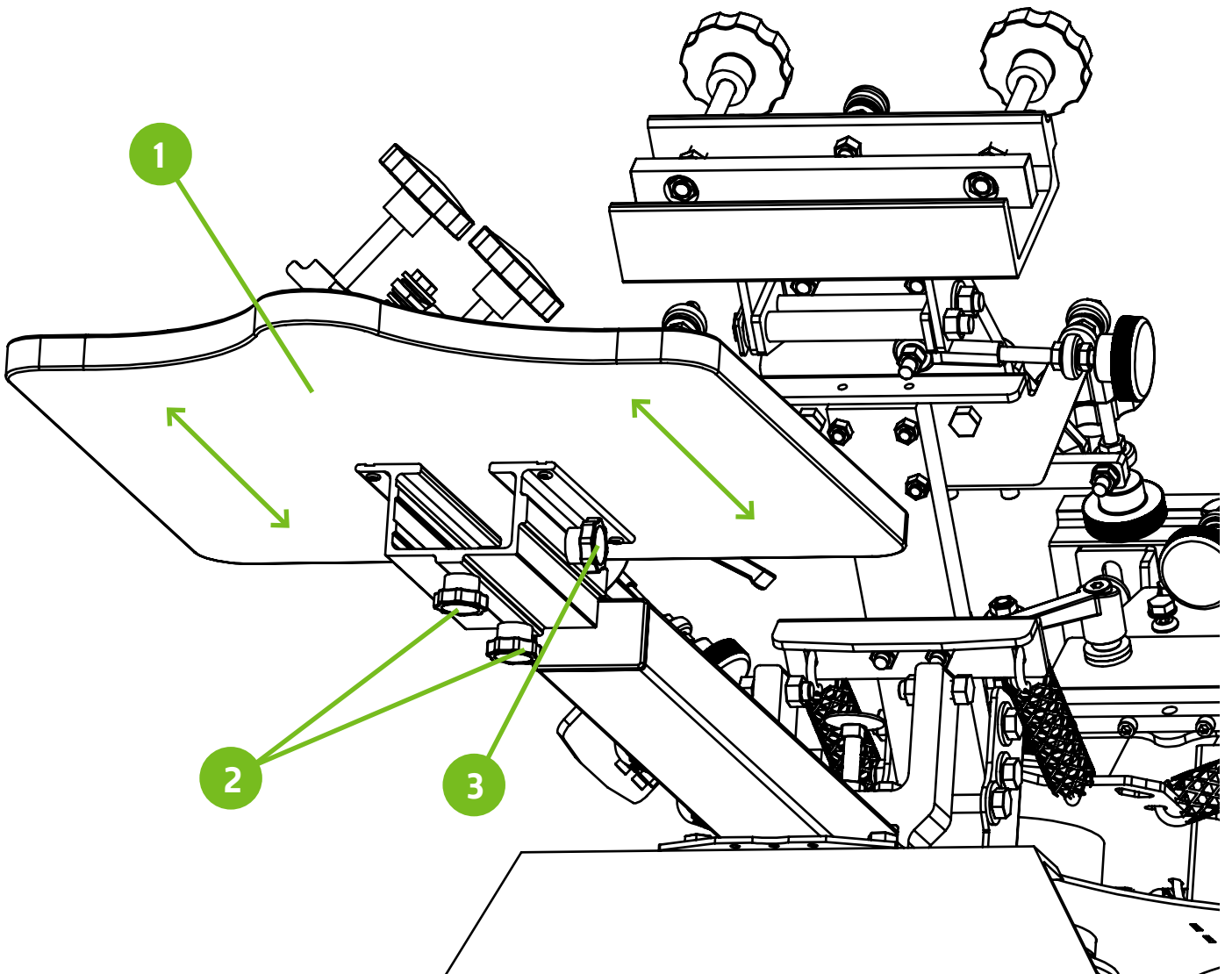

Step 7

Off-contact and tilt adjustments. First lock the screen in place with the screen clamping knobs (1).

Next, loosen the off-contact nuts (2) with a 9/16" wrench. Set the desired off-contact position and retighten the nuts.

Lastly, set the tilt angle of the screen by first loosening the tilt locking nuts (3) and the loosen the wing nut (4). Make tilt adjustment with the tilt knob (5) until you have reached the desired screen angle. Once the adjustment has been made retighten all 3 of the nuts.

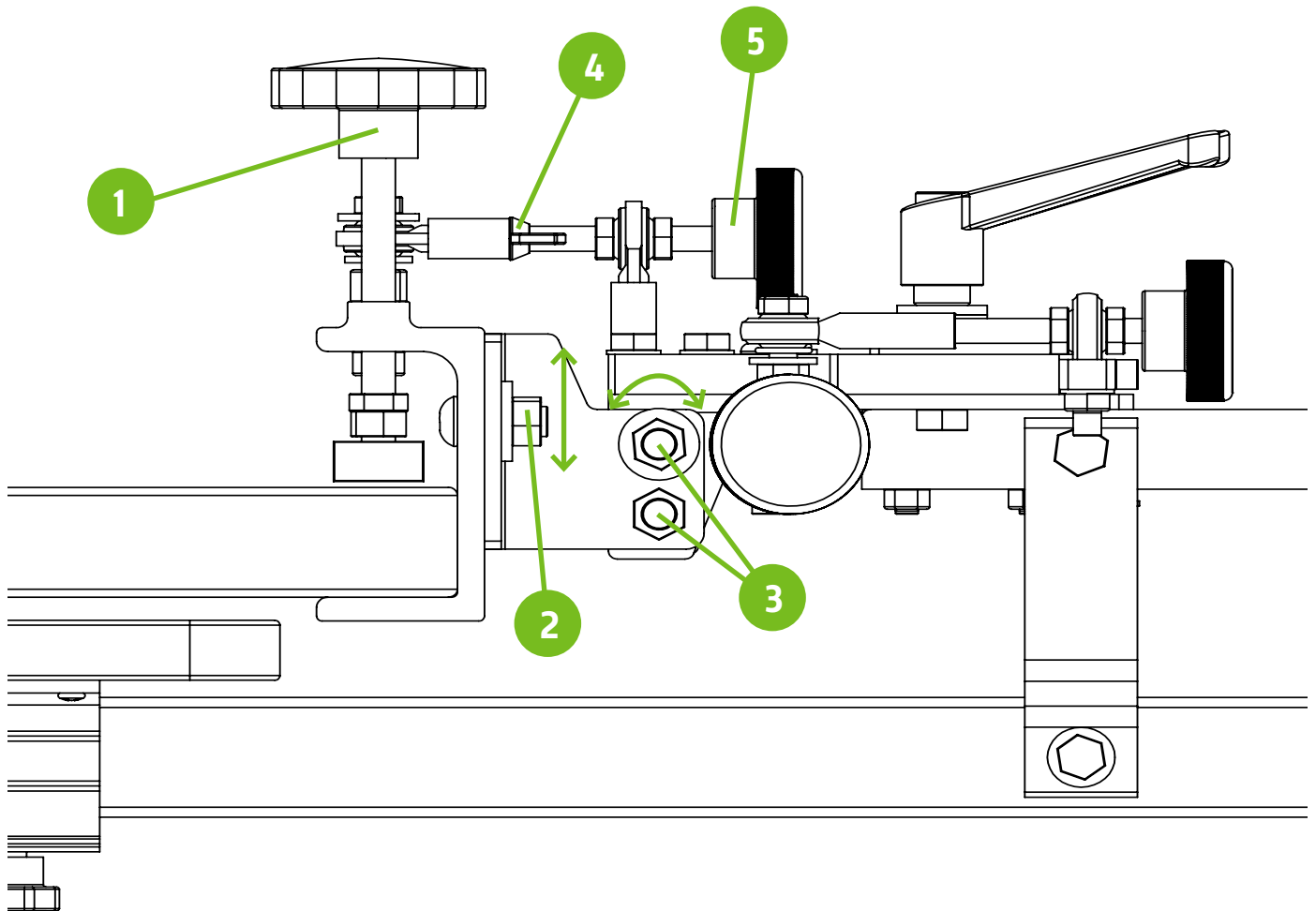

PRTB-RH250-4X1

RILEY HOPKINS 250 4 COLOR, 1 STATION SCREEN PRINTING PRESS WITH MICRO

Tag	NAME/ID	DESCRIPTION
1	PLWD-WIN16X16N-LOW	PLATEN ASSEMBLY WITH BRACKET
2	PRSA-RH250CLAMP	SCREEN CLAMP ASSEMBLY
3	PRSA-RH250PNTHD	PRINT HEAD ASSEMBLY
4	PRSA-SPRINGKIT	MESH COVERED SPRING
5	PRHD-HC3/8NC1-1/2NYBLK	3/8"-16 X 1-1/2 NYLON BOLT BLACK
6	MFPD-RH250MTGFT11	MOUNTING FEET FOR RH250 4X1 PRESS

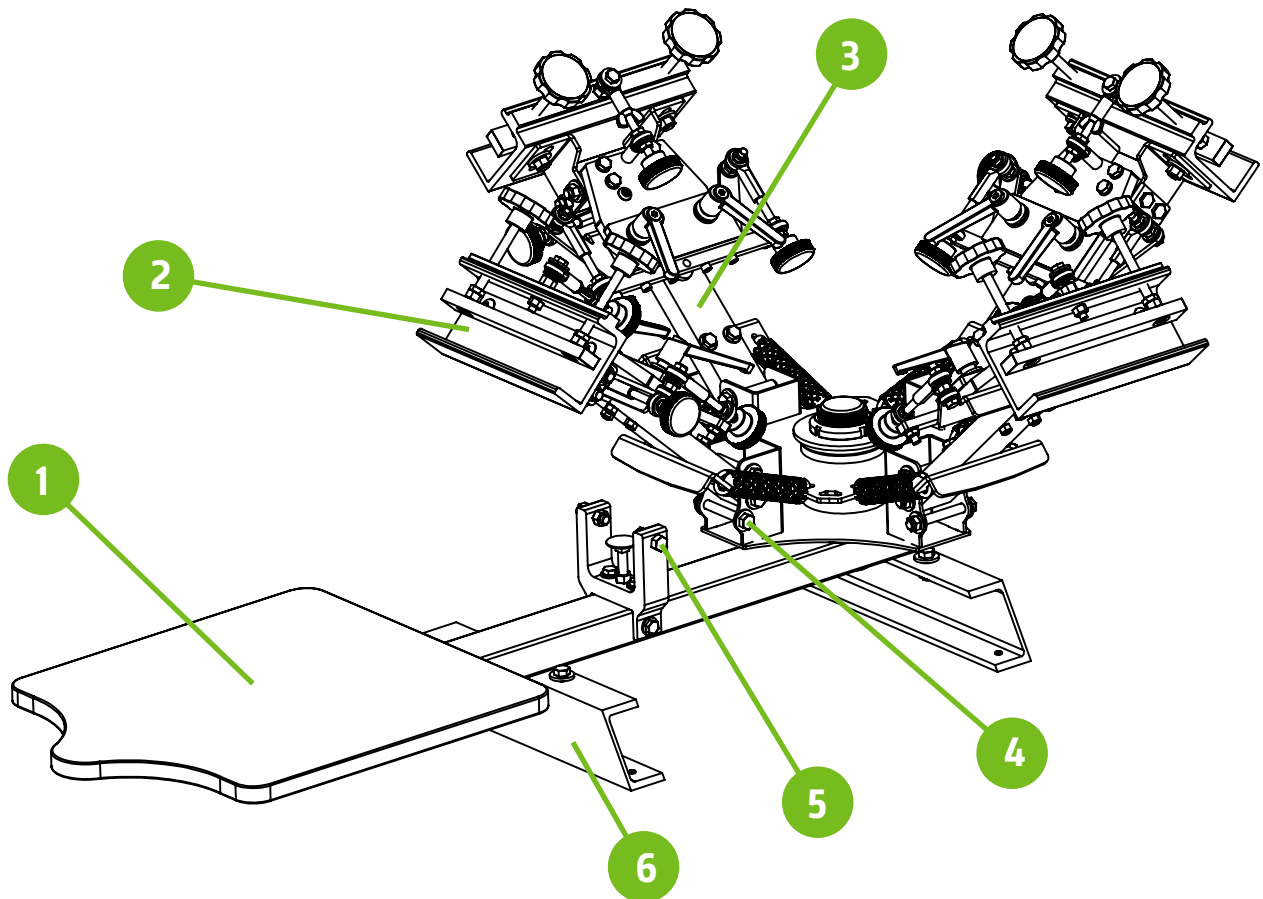

PRSA-RH250PNTHD

RILEY HOPKINS 250 PRINT HEAD ASSEMBLY WITH MICRO

Tag	NAME/ID	DESCRIPTION	QTY
1	PRCO-KNBRCHT3/8NCFM	3/8 -16 INCH COURSE RATCHET HANDLES	2
2	PRCO-BRNZB3/8ID1/2LG	3/8" X 1" SINTERED BRONZE BUSHING	2
3	MFPD-RH250SPGPLT	RH250 COLOR ARM SPRING PLATE	1
4	PRCO-RDED5/16RHML	5/16"-24 RIGHT HAND MALE ROD END	3
5	PRHD-SCRWCVR5/16	5/16" RUBBER SCREW COVER	2
6	PRCO-KNBKN-L5/16NF2-3/4ML	1-3/4" KNURLED KNOBS 5/16-24 X 2-3/4" STUD	4
7	PRCO-RDED5/16RHFMLS	5/16"-24 RIGHT HAND TREAD FEMALE ROD END-LONG SHANK	3
8	PRHD-WINGNT5/16NF-SS	5/18-24 WING NUT	1
9	PRCO-RDED5/16RHFM	5/16"-24 RIGHT HAND FEMALE ROD END	2
10	PRSA-RH250CLAMP	RILEY 250 SCREEN CLAMP ASSEMBLY	1

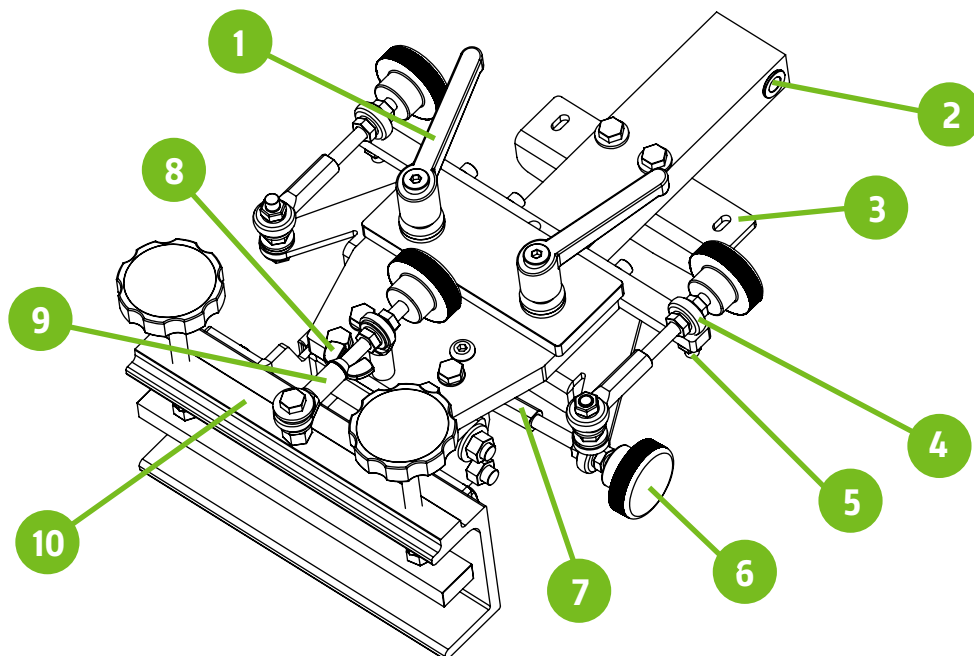



While we take pride in our quality and do our best to ensure your satisfaction, Riley Hopkins™/Ryonet® does not assume any liability for damages, whether consequential or incidental, that may result from the misuse of below stated specifications.

LIMITED WARRANTY

GENERAL PROVISIONS: The warranties described below apply ONLY to the original purchasers of new Riley Hopkins™ presses from Ryonet®, purchased on or after April 20, 2013. Under these warranties, Ryonet® will repair or replace, as Ryonet® elects, covered defective parts, materials, or workmanship without charge for parts or the reasonable cost of labor related thereto. Ryonet® will use only new or re-manufactured parts or components furnished by Ryonet® or a Ryonet®-authorized third party.

WARRANTY DURATION: A lifetime warranty shall apply to covered Riley Hopkins™ presses, parts, components and materials as set forth below.

WHAT IS COVERED: This warranty covers all non-wearable parts, non-wearable components, and non-wearable materials of new Riley Hopkins™ presses. HOWEVER, the following items are excluded from the scope of this warranty: expendable parts (including but not limited to bearings, springs, nylon bolts, oilites and fasteners). FURTHER, Ryonet® does not warrant failure of parts or components resulting from misuse or lack of proper maintenance, or improper installation.

WHAT IS NOT COVERED: Installation, inspection, and routine maintenance costs are the sole responsibility of the purchaser; used equipment; any equipment modified or altered in any way not approved by Ryonet® in writing including, but not limited to, disassembling bearing components; routine maintenance and lubrication; consequences of negligence, misuse, accident, or improper application, installation, or storage of the press; consequences of any service performed by someone other than a Ryonet®-authorized provider.

SECURING WARRANTY SERVICE: Warranty service must be requested of the nearest Ryonet® location. At the time of requesting warranty service, the person or entity requesting warranty service must be prepared to present evidence that it was the original purchaser of the Riley Hopkins™ press(es).

Written authorization must be obtained from Ryonet® before any part will be accepted. In order to return such defective part, contact Ryonet® to return such part freight prepaid. Replacement parts are sent out freight collect. Parts sent out prior to receiving defective part will be sent C.O.D., cost plus freight. Upon return of defective part, if it is deemed that the part was not damaged by customer but failed, the cost of the replacement part will be refunded.

NO REPRESENTATIONS OR IMPLIED WARRANTIES: WHERE PERMITTED BY LAW, RYONET® NOR ANY RYONET® AFFILIATE MAKES ANY GUARANTIES, WARRANTIES, CONDITIONS, REPRESENTATIONS, EXPRESS OR IMPLIED PROMISES, ORAL OR WRITTEN, AS TO THE NONOCCURENCE OF ANY DEFECT, THE QUALITY, OR PERFORMANCE OF RILEY HOPKINS™ PRESSES OTHER THAN THOSE SET FORTH HEREIN. FURTHER, RYONET® NOR ITS AFFILIATES DO NOT MAKE ANY IMPLIED WARRANTIES OR CONDITIONS OF MERCHANTABILITY OR FITNESS OTHERWISE PROVIDED BY THE UNIFORM COMMERCIAL CODE OR REQUIRED BY LAW TO THE FULLEST EXTENT PROVIDED BY LAW EXCEPT AS SET FORTH HEREIN. LIMITATION OF LIABILITY: The remedies set forth in this warranty are the purchaser's exclusive remedies in connection with the performance of, or any breach of any guarantee, condition, or warranty with respect to any new Riley Hopkins™ presses. In the event the above warranty fails to correct purchaser's performance problems caused by defects in workmanship and/or materials, purchaser's exclusive remedy shall be limited to payment for actual damages in an amount not to exceed the cost of the press. IN NO EVENT SHALL RYONET OR ANY AFFILIATE OF RYONET® BE LIABLE FOR INCIDENTAL OR CONSEQUENTIAL DAMAGES FOR INJURIES TO THE FULLEST EXTENT PROVIDED BY LAW, INCLUDING BUT NOT LIMITED TO, LOSS OF PROFITS, LOSS OF MERCHANDISE, SUBSTITUTION, OR OTHER COMMERCIAL LOSS, FOR DAMAGE SUFFERED BY PURCHASER ARISING FROM A RILEY HOPKINS™ PRESS, UNLESS SUCH DAMAGES OR INJURIES ARE CAUSED BY THE GROSS NEGLIGENCE OR INTENTIONAL ACTS OF RYONET®. RYONET® FURTHER DISCLAIMS ALL LIABILITY FOR BODILY INJURIES TO THE FULLEST EXTENT PROVIDED BY LAW. NO SELLER'S WARRANTY: No person or entity, other than Ryonet®, who sells the Riley Hopkins™ press has the authority to make any guarantee, representation, promise, or warranty with respect to any Riley Hopkins™ press unless the person or entity delivers to the purchaser a separate written guaranty certificate specifically guaranteeing the press, in which case Ryonet® shall have no obligation to the purchaser. Neither original Riley Hopkins™ manufacturers, distributors, or dealers, nor any other person or entity, has any authority to make any representation or promise on behalf of Ryonet® or to modify the terms or limitations of this warranty in any way.

ADDITIONAL INFORMATION

For additional information concerning the Riley Hopkins™/Ryonet® Press Warranty, contact support@ryonet.com or 1-800-314-6390

Riley Hopkins[®]