

ArteVino



CATALOGUE

Wine cabinets, storage solutions, wine bars



ArteVino

A brand belonging to the EuroCave Group, the world leader in the wine serving and storage market, ArteVino draws on the Group's expertise to design wine cabinets of the highest possible standard.

ArteVino wine cabinets recreate the best possible environment to ensure your best bottles mature in optimal conditions. With a modern, elegant design and a universal shelf designed to adapt to your needs, ArteVino



CONTENTS

Love of wine	› 4
ArteVino expertise	› 5
Choosing the right wine cabinet	› 9
Our wine cabinets	
Oxygen	› 12
COSY	› 22
Our wine bar: Wine Art	› 28
Our storage solutions	
Modulocube	› 32
Modulorack	› 33

wine cabinets fit perfectly into your interior and guarantee enjoyable experiences shared round a glass of wine.

LOVE OF WINE

THE LIFETIME OF WINE IN 4 PHASES

Wine is a living product, which once bottled, is a semi-finished product which improves over time. The maturing period is essential for improving wine. Its environment during this phase has a direct impact on its final quality.

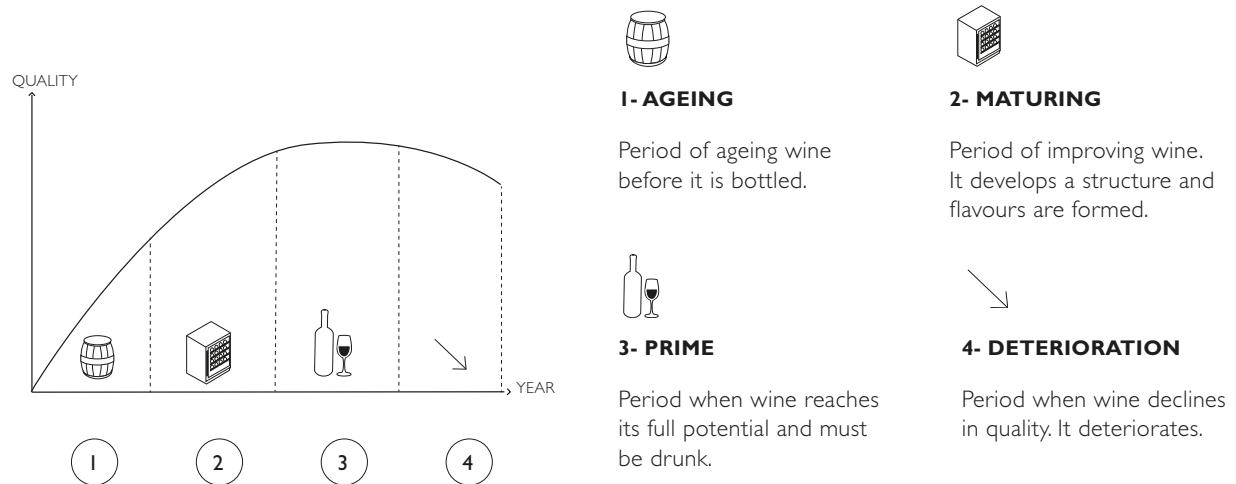

A wine cabinet must bring together all the criteria required for optimal wine maturing, allowing you to recreate at home, on a smaller scale, the ideal storage conditions found in a natural cellar.

Only a product which meets all the following criteria can be considered a good wine cabinet for maturing or serving wine.



LOVE OF WINE

THE IDEAL ENVIRONMENT FOR OPTIMAL WINE MATURING IN 6 CRITERIA



TEMPERATURE

The temperature inside the cabinet must remain stable, around 12°C (for all types of wine). The storage temperature of wine influences the rate at which it matures and its quality.



HUMIDITY

The humidity level must be 65 - 80%. Lack of humidity causes corks to dry out resulting in wine seeping out and loss of flavour. Too much humidity creates condensation and causes mould to develop and labels to peel off.



LACK OF VIBRATION

Movement is wine's enemy. Vibrations are harmful to it. The many vibrations caused by daily life (trains, the underground, busy streets...) or by the cabinet itself can prevent optimal maturing, since they are harmful to wine's development process. It is therefore essential to protect your bottles from all vibration.



AIR CIRCULATION

Lack of ventilation and poor air circulation can cause mould and bacteria to develop. The air inside the cabinet must be constantly renewed to prevent these harmful substances from developing.

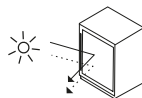

PROTECTION FROM LIGHT

For optimal maturing, wine must be protected from U.V. rays emitted by light which degrades tannins.



SUITABLE STORAGE

The specific and varied shape of bottles (Bordeaux, Burgundy, Alsace...) and their considerable weight require specially adapted storage. In addition, bottles must be easy to access for maximum user-friendliness.

OUR EXPERTISE

Owing to its expertise and know-how, accumulated over more than 20 years, ArteVino delivers the best results in terms of bottle storage and daily use of your wine cabinet.



PERFORMANCE

Our only objective when developing all our products ranges is to observe the 6 criteria required for optimal maturing to ensure that you have the best possible wine drinking experience.



POWER CONSUMPTION

ArteVino's wine cabinet ranges fall into A - A+ energy classes owing to their high-performance materials. Fitted with advanced electronics, high-density insulation, and a high-performance compressor, they reduce unnecessary power consumption.



QUALITY

ArteVino selects durable materials for both the cabinet and its equipment.

ArteVino uses aluminium rather than plastic for its interior walls; thereby reducing bad odours and optimising humidity management inside the cabinet. The steel frame of the cabinet body does not warp over time. The insulation is reinforced for improved temperature maintenance. Sturdiness of the storage zones is ensured by use of our universal shelf, in beech wood.



ORIGINE FRANCE GARANTIE

All ArteVino wine cabinets are manufactured in France and have been certified with the Origine France Garantie label since 2012. It is in Fourmies, Nord, at the EuroCave Group's factory, that your wine cabinet is produced and rigorously tested. French manufacturing which ensures quality control from cabinet production right through to after-sales service.

┌ CLOSE UP ON ... ┐

YOUR CABINET'S GLASS DOOR

Double-glazing with low-emission technical glass, reinforced by use of argon gas. Using this technical glass reduces the risk of condensation, reduces energy consumption and offers 97% U.V. screening.

THE ARTEVINO UNIVERSAL SHELF

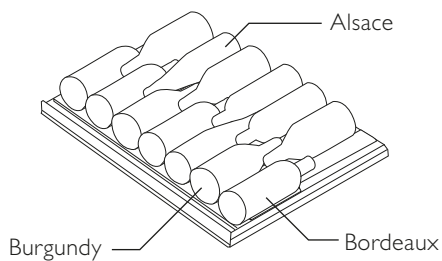

The ArteVino universal shelf, in beech wood, is designed to hold all bottle sizes (Bordeaux, Burgundy, Champagne...)

- Modular system: you have the option of using your shelf in sliding, storage or display mode.
- Fast, easy identification: the label holder allows you to number your shelves and identify the different bottles.

CAN BE INSTALLED IN ANY ROOM IN THE HOUSE.

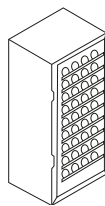

ArteVino wine cabinets can be used (depending on the model) with a room temperature of 0°C - 35°C. Which makes installation possible in a room with considerable temperature variations or in an unheated room, such as a garage. Fitted with an automatic cold temperature function, your wine is protected regardless of the outside temperature.

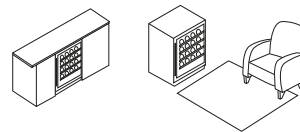

In flush-fitted or free-standing version, ArteVino wine cabinets are at home in your kitchen or living room.

Fitted with a glass door, they showcase your bottles and allow you to demonstrate your passion for wine.



CHOOSING THE RIGHT WINE CABINET

WHICH FUNCTION DO YOU REQUIRE?

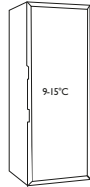

MATURING CABINET

Use: For storing and maturing wine for a period of 2 to over 20 years. Wine maturing cabinets recreate the ideal conditions found in a natural cellar to meet the 6 criteria required for optimal wine maturing.

Features: A single, adjustable temperature, uniform throughout the cabinet (ideal temperature for maturing all wine: 12°C).

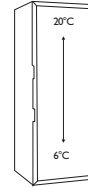

WINE SERVING CABINET

Use: Whilst wine is stored at 12°C, it is not necessarily drunk at this temperature. The serving or multi-temperature cabinet allows you to store your wine for a period of up to 2 years, at an ideal serving temperature. Can be used for all types of wine.

Features: A temperature gradient throughout the cabinet from 6°C for cooling to 20°C for bringing your red wines to room temperature.

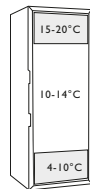

MULTI-FUNCTION CABINET

Use : One wine cabinet for many uses. For storing and bringing wine to the correct serving temperature.

Features: 3 separate compartments:

- A central compartment for storing wine.
- A lower compartment for cooling wine.
- An upper compartment for bringing your red wine to room temperature before serving.

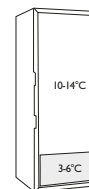

MULTI-DRINKS CABINET

Use: Maturing your wine and bringing all types of cold drinks to the correct serving temperature (champagne, fizzy drinks, beer, fruit juice) is now possible with the multi-drinks wine cabinet.

Features: 2 separate compartments:

- An upper compartment for storing and maturing wine.
- A lower compartment for preparing all types of cold drinks for serving.

CHOOSING THE RIGHT WINE CABINET

WHAT CAPACITY DO I NEED?

It is important to choose the capacity that meets your actual requirements. A cabinet which is too big will waste electricity over time. We recommend that you fill your cabinet to at least 75% of its capacity for optimal operation.



SMALL CAPACITY CABINETS

They are generally dedicated to serving or maturing.

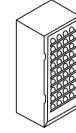

LARGE CAPACITY CABINETS

They are generally dedicated to maturing cabinets, multi-function cabinets or multi-temperature cabinets.

WHICH EQUIPMENT DO I NEED?

Shelves should not be overlooked. They are one of the 6 criteria for optimal wine storage. When choosing them, several factors should be considered:

- They must be made of high-quality materials to withstand the humidity inside the wine cabinet,
- They must have been specially designed to hold wine bottles,
- They must be able to store all types of bottles and allow air to circulate inside the cabinet.



STORAGE SHELF

Designed for a maturing cabinet to store a large number of bottles, for which regular access is not necessary.

It optimises the cabinet's capacity.



SLIDING SHELF

Designed for a serving cabinet or to offer quick and easy access to some bottles.

This format ensures optimal protection of labels by preventing scraping, and easy access to all bottles.



DISPLAY SHELF

Designed for a serving cabinet or maturing cabinet fitted with a glass door.

This format allows you to display the labels of your most prestigious bottles.

Very often, a mixed layout is adopted. In this way, ArteVino offers a shelf which adapts to your needs, able to be used in storage, sliding or display version, offering you the possibility of changing your layout according to your requirements.

CHOOSING THE RIGHT WINE CABINET

DO I NEED FLUSH-FITTED OR FREE-STANDING?

Flush-fitted and free-standing cabinets are not designed in the same way. Adaptations are required for the flush-fitted ranges in order to ensure performance of the cooling system in an enclosed space.

If you are thinking of flush-fitting your wine cabinet in a unit, opt for a model specifically designed for this purpose, such as *Cosy*.



DO I NEED A GLASS OR SOLID DOOR?

ArteVino wine cabinets can be fitted with a solid or glass door, depending on your requirements.

A glass door guarantees protection of your wine whilst providing a unique design for installation in a living area. A solid door offers reinforced insulation allowing management of greater variations in temperature, for installation in a room which is less visible and unheated.



Glass door



Solid door





WINE CABINET OXYGEN

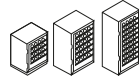

3 sizes



4 functionalities



98 - 230 bottles



Origine France Garantie



Low power consumption



Low noise levels



Visual alarms



Cold temperature function

PROTECT YOUR WINE,
OPTIMISE YOUR STORAGE CAPACITY

Cabinets specially designed for your best wines
with a wide choice of functionalities and sizes.

ArteVino

OXYGEN

MEETS ALL YOUR REQUIREMENTS

Our Oxygen range offers you the possibility of choosing the cabinet which adapts to your requirements and your interior:



VERSATILITY

The different functionalities: multi-drinks, multi-function, serving or maturing cabinet, allow you to choose the cabinet that suits you. Our range is available in small, medium or large models, in this way adapting to your space and the bottle capacity you require, from 98 - 230 bottles.



MODULARITY & ERGONOMICS

As a real specialist, ArteVino has fitted all its range with universal shelves. These beech wood shelves can hold all bottle sizes and change from storage to sliding or display mode.

Optimal storage flexibility and quality!



ENVIRONMENTALLY-FRIENDLY MODELS

Incorporating the latest, highest performance technologies, our Oxygen range offers low energy consumption. Its low sound level is also a real advantage in living rooms.

PEACE OF MIND

Comprehensive equipment to guarantee maximum safety for your wine every day – automatic cold temperature function, temperature fault visual alarm, lock.



**MATURING
CABINET**

A temperature from 10°C - 14°C to safely mature your wine.

**SERVING
CABINET**

A staggered temperature to have all your wines at an ideal serving temperature.

**MULTI-FUNCTION
CABINET**

A main zone for storing your wine. A compartment for bringing red wine to room temperature and a compartment for cooling (champagne, white, rosé wine etc.).

**MULTI-DRINKS
CABINET**

An upper compartment dedicated to maturing your wine and a lower zone for chilling all types of drinks: champagne, fizzy drinks, beer or fruit juice.

OXYGEN

MEETS ALL YOUR REQUIREMENTS

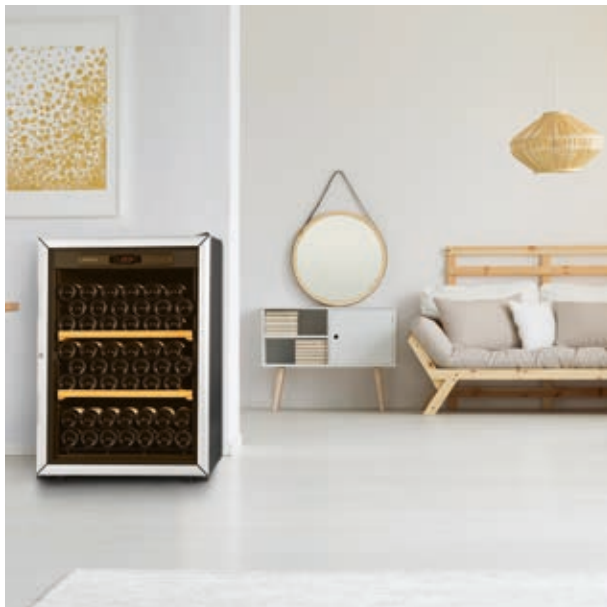

2 DOORS

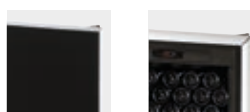

Solid door

Silver glass door

2 COLOURS



Tobacco plane tree*
PL

Black surf
NS

REVERSIBLE DOOR

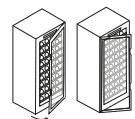

Except for solid doors

* For solid doors – single-temperature model

OXYGEN

FEATURES – MATURING CABINETS

Function

Single-temperature

Dimensions

3 sizes

Cabinet temperature setting range

9°C - 15°C

(one temperature throughout the cabinet)

Recommended room temperature range

0°C - 35°C – solid door

0°C - 30°C – glass door

Type of shelf

Universal, in beech wood

Sound emission

37 dB(A)

Feet

2 adjustable feet

Type of door

Solid door

U.V.-proofed double-glazed glass door

Lock

Yes

Visual alarm

Yes, temperature alarm

Colour

Black or tobacco plane tree

Standard equipment bottle layout

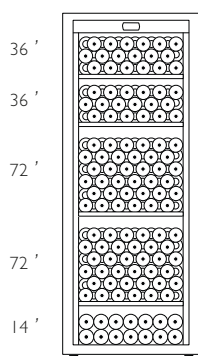

230 bottles*
4 storage shelves

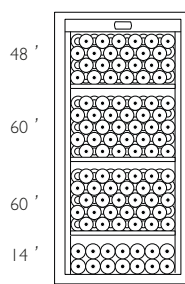

182 bottles*
3 storage shelves

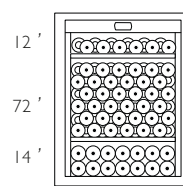

98 bottles*
1 sliding shelf
1 storage shelf



The models



OXGIT230PPD



OXGIT230PPG



OXGIT230NPG



OXGIT230NPD



OXGIT230NVD



OXMIT182PPD



OXMIT182NPD



OXMIT182NVD



OXPIT98PPD



OXPIT98NPD



OXPIT98NVD

* Traditional Bordeaux bottles – hollow base.

OXYGEN

FEATURES – SERVING CABINET

Function

Multi-temperature

Dimensions

3 sizes

Cabinet temperature gradient

6°C - 20°C

Temperature setting range at bottom of cabinet

6°C - 10°C

Temperature setting range at top of cabinet

15°C - 20°C

Recommended room temperature range

12°C - 30°C

Type of shelf

Universal, in beech wood

Sound emission

37 dB(A)

Feet

2 adjustable feet

Type of door

Solid door
U.V.-proofed double-glazed glass door

Lock

Yes

Visual alarm

Yes, temperature alarm

Colour

Black

Standard equipment bottle layout

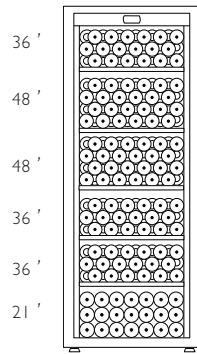

225 bottles*
5 storage shelves

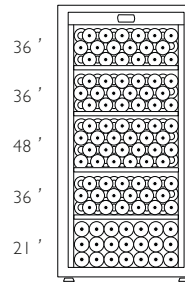

177 bottles*
4 storage shelves

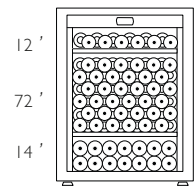

98 bottles*
1 sliding shelf
1 storage shelf



The models



OXGMT225NPD



OXGMT225NPG



OXGMT225NVD



OXMMT177NPD



OXMMT177NVD



OXPMT98NPD



OXPMT98NVD

*Traditional Bordeaux bottles – hollow base.

OXYGEN

FEATURES – MULTI-FUNCTION CABINET

Function

3-temperature

Compartments

3 separate compartments:

A lower compartment for cooling, a central compartment for maturing and an upper compartment for bringing red wine to room temperature.

Dimensions

2 sizes

Temperature setting range for the red service temperature compartment

15°C - 20°C

Temperature setting range for the central compartment

10°C - 14°C

Temperature setting range for the lower compartment

4°C - 10°C

Recommended room temperature range

12°C - 30°C

Type of shelf

Universal shelf in beech wood and 2 wooden compartments

Sound emission

37 dB(A)

Feet

2 adjustable feet

Type of door

Solid door
U.V.-proofed double-glazed glass door

Lock

Yes

Visual alarm

Yes, temperature alarm

Colour

Black

Standard equipment bottle configuration

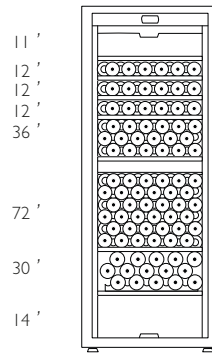

199 bottles*
3 sliding shelves
3 storage shelves

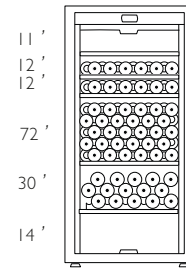
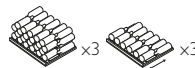

151 bottles*
2 sliding shelves
2 storage shelves



OXG3T199NPG



OXG3T199NPD



OXG3T199NVD



OXM3T151NPD



OXM3T151NVD

OXYGEN

FEATURES – MULTI-DRINKS CABINET

Function

2-temperature

Compartments

2 separate compartments:

A lower compartment for chilling and an upper compartment for maturing

Dimensions

I size

Temperature setting range for the chilling compartment

3°C - 6°C

Temperature setting range for the main compartment

10°C - 14°C

Recommended room temperature range

12°C - 25°C

Type of shelf

Universal in beech wood
Multi-drinks shelf

Sound emission

37 dB(A)

Feet

2 adjustable feet

Type of door

Solid door
U.V.-proofed double-glazed glass door

Lock

Yes

Visual alarms

Yes, temperature alarm

Colour

Black



Maturing compartment with maximum capacity for 144 bottles.*

Partition which allows separation of the two compartments and bottle storage.

Chilling compartment can be set from 3 - 6°C for all types of bottles.



① Removable rack designed for bottled beer, cans and other fizzy drinks...



OXG2T206NPD



OXG2T206NPG



OXG2T206NVD

* Traditional Bordeaux bottles – hollow base

OXYGEN

TECHNICAL DATA

Reference	Type of door	Useful volume	Dimensions H x W x D (mm)	European Union ¹ 230V 50Hz - R600a gas		United States ² 115V 60Hz - R600a gas	Maximum bottle capacity
				Annual energy consumption kWh/year	Energy efficiency class	Annual energy consumption kWh/year	
MATURING CABINET – SINGLE-TEMPERATURE							
OXGIT230 NPD/NPG/ PPD/PPG	Solid	460	1,825 x 680 x 700	128	A+	172	230
OXGIT230 NVD	Glass	460	1,825 x 680 x 690	165	A	212	230
OXMIT182 NPD/PPD	Solid	355	1,480 x 680 x 700	121	A+	143	182
OXMIT182 NVD	Glass	355	1,480 x 680 x 690	157	A	172	182
OXPI T98 NPD/PPD	Solid	225	960 x 680 x 700	114	A+	114	98
OXPI T98 NVD	Glass	225	960 x 680 x 690	146	A	143	98
SERVING CABINET – MULTI-TEMPERATURE							
OXGMT225 NPD/NPG	Solid	460	1,825 x 680 x 700	128	A+	172	225
OXGMT225NVD	Glass	460	1,825 x 680 x 690	165	A	212	225
OXMMT177NPD	Solid	355	1,480 x 680 x 700	121	A+	143	177
OXMMT177NVD	Glass	355	1,480 x 680 x 690	157	A	172	177
OXPI T98NPD	Solid	225	960 x 680 x 700	114	A+	114	98
OXPI T98NVD	Glass	225	960 x 680 x 690	146	A	143	98
MULTI-FUNCTION CABINET – 3-TEMPERATURE							
OXG3T199 NPD/NPG	Solid	450	1,825 x 680 x 700	128	A+	172	199
OXG3T199NVD	Glass	450	1,825 x 680 x 690	165	A	212	199
OXM3T151NPD	Solid	345	1,480 x 680 x 700	121	A+	143	151
OXM3T151NVD	Glass	345	1,480 x 680 x 690	157	A	172	151
MULTI-DRINKS CABINET – 2-TEMPERATURE							
OXG2T206 NPD/NPG	Solid	445	1,825 x 680 x 700	168	A	212	206
OXG2T206NVD	Glass	445	1,825 x 680 x 690	215	B	252	206

¹ In accordance with Commission Delegated Regulation (EU) n° 1060/2010 dated 28 September 2010 completing directive 2010/30/EU of the European Parliament and the Council. Energy consumption calculated based on results obtained over 24 hrs in standard test conditions (25°C / 77°F). Actual energy consumption depends on the operating conditions and location of the appliance.

² Comply with DEPARTMENT OF ENERGY – 10 CFR Part 430 – Energy Conservation Program: Energy Conservation Standards for Miscellaneous Refrigeration Products.





WINE CABINET **COSY**



1 size



2 functionalities

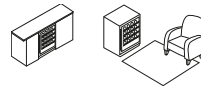

Flush-fitted or free-standing



Origine France Garantie



39 - 52 bottles



Bottle lighting



Visual alarms



Low power consumption

INDULGE YOUR LAYOUT DESIRES

The compact cabinet body and elegant design of Cosy were thought out to fit in perfectly in your kitchen, with quick and easy installation. But the Cosy range is equally at home in your living room and offers the best conditions for serving, storing and maturing your wine.

COSY

DESIGN & MODULARITY



OPTIMAL MODULARITY

Compact in size but has capacity to store up to 52 bottles. Its equipment is designed to make it as ergonomic as possible with ArteVino universal shelves.

Customisation of your cabinet's layout!



HIGH-QUALITY MATERIALS

As is the case for all its ranges, ArteVino demands the highest standards in terms of the materials used.

ONE SHELF, SEVERAL USES



Storage mode

Optimised bottle capacity



Sliding mode

Easy access to your bottles



Display mode

Showcasing your best bottles

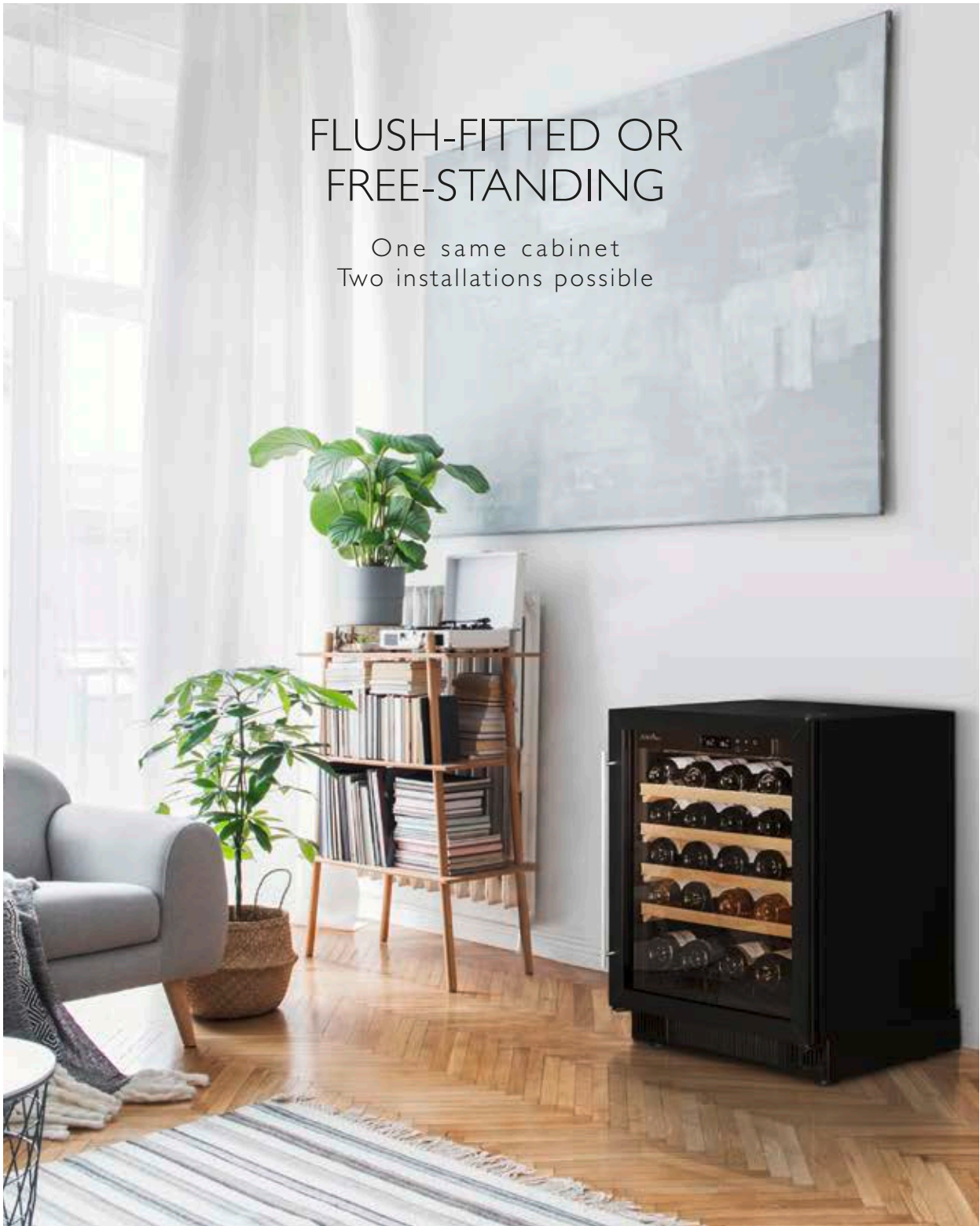

FLUSH-FITTED OR FREE-STANDING

One same cabinet
Two installations possible

FLUSH-FITTED OR FREE-STANDING

The compact cabinet body, which corresponds to kitchen designer standards, is designed to fit perfectly into your kitchen with quick and easy installation. But it is equally at home in your living room thanks to its exterior.

OPTIMAL HUMIDITY

A humidity cartridge comprising of clay balls is supplied* with your wine cabinet. It allows optimal humidity levels to be maintained inside the wine cabinet according to your requirements. It is placed at the base of the wine cabinet.

DESIGN

Designed to fit in perfectly in your interior: stainless steel handle, LED lighting for a relaxing atmosphere in your interior, elegant black door frame.

* Single-temperature model

COSY

FEATURES – MATURING CABINET

Function

Single-temperature

Dimensions

I size

Cabinet temperature setting range

9°C - 15°C

Recommended room temperature range

0°C - 30°C

Type of shelf

Universal, in beech wood

Sound emission

41 dB(A)

Feet

4 adjustable feet

Possible to adjust height

816-875 mm

Lighting

LED, white in colour

Type of door

U.V.-proofed double-glazed glass door

Visual alarms

Temperature alarm
Sensor fault alarm
Humidity fault alarm

Standard equipment bottle layout

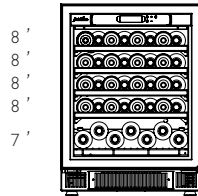

39 bottles*
4 sliding shelves

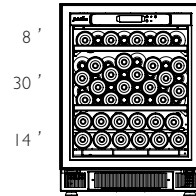

52 bottles*
1 sliding shelf
1 storage shelf



Model



COSYPIT

FLUSH-FITTING DIAGRAM

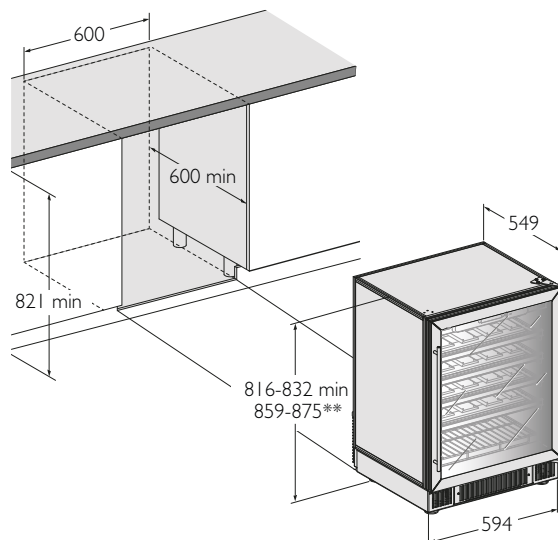
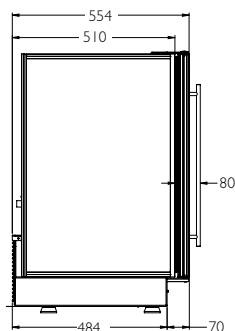
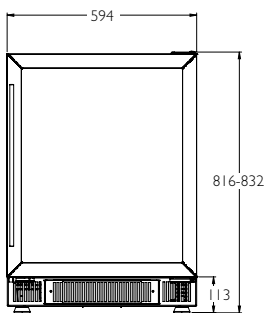

** With the feet raising pieces.

COSY

FEATURES – SERVING CABINET

Function

Multi-temperature

Temperature gradient of the cabinet

6 - 20°C

Temperature setting range for the bottom of the cabinet

6°C - 10°C

Temperature setting range for the top of the cabinet

15°C - 20°C

Recommended room temperature range

12°C - 30°C

Type of shelf

Universal, in beech wood

Sound emission

41 dB(A)

Feet

4 adjustable feet

Possible to adjust height

816-875 mm

Lighting

LED, white in colour

Type of door

U.V.-proofed double-glazed glass door

Visual alarms

Temperature alarm
Sensor fault alarm
Humidity fault alarm

Standard equipment bottle layout

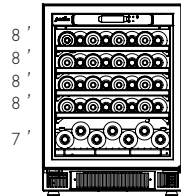

39 bottles*
4 sliding shelves



Model



COSYPMT

TECHNICAL DATA

Reference	Type of door	Useful volume (litre)	Dimensions H x W x D (mm)	European Union ¹ 230V 50Hz - R600a gas		United States ² 115V 60Hz - R600a gas	Maximum bottle capacity
				Annual energy consumption kWh/year	Energy efficiency class	Annual energy consumption kWh/year	
MATURING CABINET – SINGLE-TEMPERATURE							
COSYPIT	Glass	116	816-875 x 594 x 549	132	A	172	52
SERVING CABINET – MULTI-TEMPERATURE							
COSYPMT	Glass	116	816-875 x 594 x 549	132	A	172	52

¹ In accordance with Commission Delegated Regulation (EU) n° 1060/2010 dated 28 September 2010 completing directive 2010/30/EU of the European Parliament and the Council. Energy consumption calculated based on results obtained over 24 hrs in standard test conditions (25°C / 77°F). Actual energy consumption depends on the operating conditions and location of the appliance.

² Comply with DEPARTMENT OF ENERGY – 10 CFR Part 430 – Energy Conservation Program: Energy Conservation Standards for Miscellaneous Refrigeration Products.

* Traditional Bordeaux bottles – hollow base.

WINE ART

THE HOME WINE BAR



The perfect addition to your wine maturing cabinet, our Wine Art wine bar is an exclusive two-in-one product. It brings your wine to the correct temperature and vacuum seals it for optimal preservation of open bottles.

WINE ART

THE HOME WINE BAR

With Wine Art, say goodbye to wasted open bottles!



OPTIMAL SERVING

It offers you the possibility of bringing two wine bottles to an ideal serving temperature. With two separate compartments, you can open the two bottles you require (red and/or white) and prepare your wine for serving.



MODULARITY & ERGONOMICS

Thanks to its air vacuum system, Wine Art protects your wine from oxidation for up to 10 days* after opening your bottle. Easy and intuitive to handle.

KEY POINTS

- Two separate compartments: 16-18°C for red wine / 8-10°C for white wine
- Air vacuum system: protects wine from oxidation for up to 10 days*
- Easy and intuitive to use
- An understated, elegant design to fit perfectly into your interior
- An essential addition to maturing cabinets

* According to the type of wine and its vintage





OUR STORAGE SOLUTIONS

MODULOCUBE, THE SMART WINE RACK.

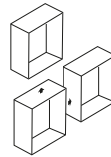

Can be changed or added to

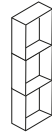

3 heights possible



Up to 50 bottles

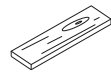

Wooden structure



MODULORACK, OPTIMISE STORAGE OF YOUR WINE CASES.

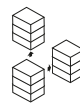

Can be changed or added to

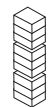

3 heights possible



Two 12-bottle cases



Steel structure

MODULOCUBE

THE SMART WINE RACK

Modulocube allows you to optimise your natural cellar's storage capacity. Easy to install, this flexible product adapts to your space. It allows all types of bottles to be stored in one single depth either together or individually with the addition of shelves (1 - 6 shelves). Rack delivered ready-to-assemble and folds easily for easy assembly.

LARGE STORAGE CAPACITY

Just one Modulocube allows you to store up to 50 traditional Bordeaux bottles. Stackable*, interlocking and flexible, combine them and you will easily increase the storage capacity of your wine storage room.



SOLID BEECH WOOD

Our partner is committed to sustainable forest management and has been recognized by PEFC certification.

KEY POINTS

- An easy storage system which can be changed or added to
- A sturdy folding rack in solid beech
- For storing all types of bottles
- Made in France

* Up to 3 heights

MODULORACK

OPTIMISE STORAGE OF YOUR WINE CASES

Based on a sliding shelf system and designed for standard dimensions of 12-bottle wine cases, Modulorack offers easy to use, flexible storage.

FLEXIBLE AND STURDY

Connect them together to assemble up to 3 heights in order to increase your wine cellar's storage capacity. Modulorack's structure is in steel for increased sturdiness and fastened to the floor; they always remain stable whatever layout is adopted.



EASY AND ERGONOMIC

Once assembled, all you have to do is insert your wine cases! The sliding shelf system allows easy access to your stored wine bottles.

KEY POINTS

- A product for storing wine cases
- An exclusive sliding shelf system
- Easy access to bottles

ArteVino



www.artevino.fr

Specifications liable to change without notice. Photos non-binding
Photo credits: Studio Guy Renaux, NelleG, KatarzynaBialasiewicz, Alexandre Zveiger, Rilueda, StudioGR, Imaginima,
Tulcarion, Nicolas Robin, Roza Restaurant (Israel)
02/2020 – Eurocave Group - 24 rue Francis de Pressensé - 69628 Villeurbanne cedex
Commercial registration no. Lyon B320316995