

T8 LED 8FT QUICK BYPASS-BALLAST BYPASSED

40W LED Replacement for Fa8 or R17d 8FT T8 (T12) Fluorescent Lamps

Type B - Double-Ended, Ballast Bypassed

Description

The T8 LED 8FT is a 40W line driven (Type B, double-ended, ballast bypassed) linear T-LED replacement for an 8FT single pin (Fa8) or double recessed contact (R17d) T8 or T12 fluorescent lamp. Its built-in universal driver allows lamp operation at 100V ~ 277V.

R17d end cap makes this a double-ended lamp, allowing installation into both Shunted and Non-Shunted sockets in the case of the Double Recessed Contact. R17d lamps are ETL Classified for safe handling and can reduce installation time by half.

This lamp emits beautiful LED light over 180° of its surface. It has a Color Rendering Index (CRI) of >80 and delivers up to 5,000 lumens of usable light. The T8 LED 8FT features an aluminum tube for improved optics and is available in 3000K, 4000K and 5000K color temperatures.

The T8 8FT LED lamp may also replace a T12 fluorescent lamp.

This lamp is rated at 50,000 hours and is backed by a five-year warranty. It contains no mercury, allowing for non-hazardous waste disposal.

This is a Type B (ballast bypassed) lamp and does not support fluorescent ballasts or LED drivers. For a fixture with Double Recessed Contact sockets, the sockets can be either Shunted or Non-Shunted.

All sockets are wired into AC line voltage.

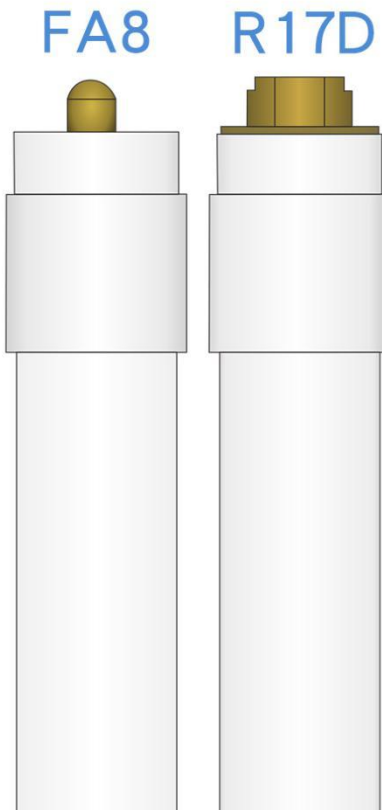

Features

- Replacement for T8 or T12 Lamps up to 75W with a 40W LED
- Quick Bypass (Type B, double-ended, ballast bypassed) Installation - supports line
- Input Voltage 100V-277V AC
- Universal Tombstone Technology (UTT) compatible with both Shunted and Non-Shunted Double Recessed Contact sockets
- Delivers up to 5,000 lumens at >=80 CRI
- CCT 3000K, 4000K and 5000K
- 50,000 hours life to L70 / 5-Year Warranty / P.C Shatter Guard

	Pin	Ballast	Length	Lumen	CRI	Power Factor	Color Temperature
8FT LED Tube Light	FA8 R17D	Bypassed Supports (100V~277V)	96 inch tube (T8 or T12)	5,000lm	>= 80	>0.95	3000K 4000K 5000K

Jen Lighting T8 LED 8FT QUICK BYPASS-BALLAST

Product Specifications

Illumination

Color Temperatures	3000K,4000K,5000K
Delivered Lumens	Up to 5,000lm
CRI	≥80
Lumen Maintenance	50,000+hours life

Electrical System

Power Factor	>0.9
CRI	Ra80, Ra85, Ra90
Input Voltage	100V~277V 50/60Hz AC Line Voltage
Lifespan	50,000+hours life
Total Power	40W
Lamp Wattage Replaced	Up to 75W(T8 or T12)
Dimming	No

Physical Double Recessed Contact

Weight	0.55kg/pcs
Housing and Finish	Aluminum with PC Cover (Clear or Frosted)
Beam Angle	180

Environment

Ambient Operating Temp	-28°F to 113°F (-20°C to 45°C)
Ambient Operating Humidity	Dry and Damp Certified

Installation

Line Voltage	Fa8 socket or R17Dsocket(Shunted or Non-Shunted)
Ballast Installation	Bypass Ballast.

Certifications & Qualifications

ETL(US and Canada)	Classified ETL Intertek
FCC	Complies with Parts 15A/B
RoHS Compliant	Contains no led or mercury
Listed	No category

Warranty:5 years

Product Dimensions

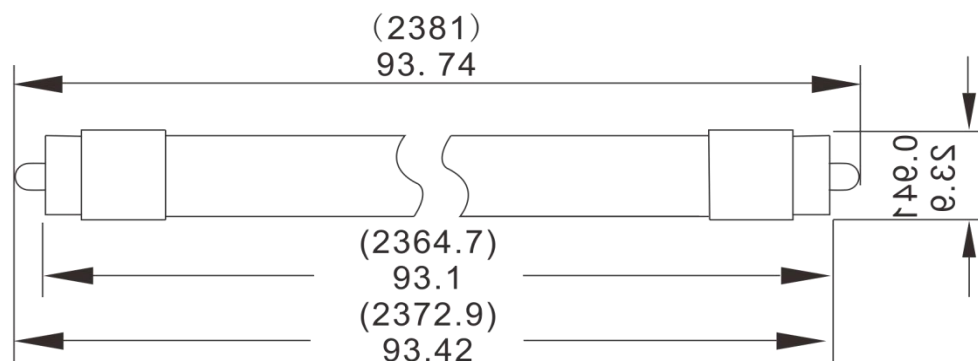

T8 LED 8FT QUICK BYPASS-BALLAST BYPASSED

- Lamp installation in the following conditions and applications *voids the product warranty*:

- Line voltage above 277VAC
- LED Drivers or with a ballast
- Gasketed, fully enclosed fixtures
- Installation in wet environments
- Installation in broken, cracked, dirty or rusted tombstones
- Improper wiring to the tombstones/lamp
- Total Power equals lamp power because the ballast has been bypassed or removed.

- **CAUTION**

Turn power off when installing the lamp.

CAUTION - IF THE LAMP OR LUMINAIRE EXHIBITS UNDESIRABLE OPERATION (BUZZING, FLICKERING, ETC.), IMMEDIATELY TURN OFF POWER, REMOVE LAMP FROM LUMINAIRE AND CONTACT MANUFACTURER.

- Double-Ended Electrical Connection & Single-Ended Electrical Connection

Double-Ended Wiring:

Single-Ended Wiring:

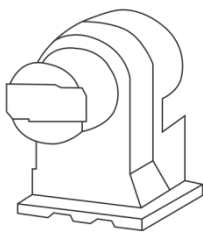
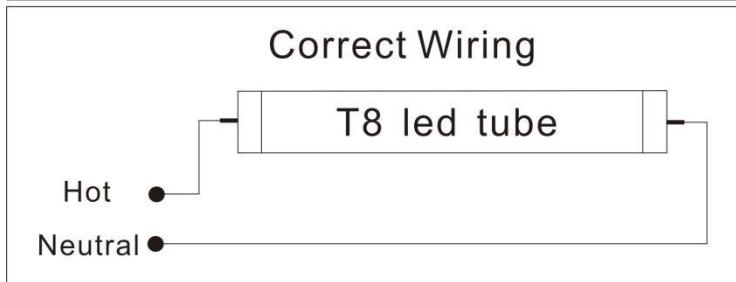
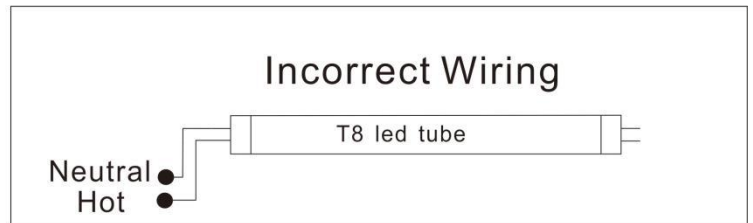
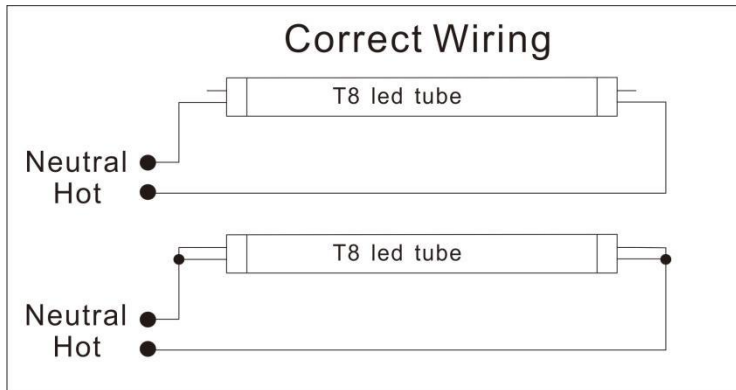

Socket Type

Double Recessed Contact (R17d)

Shunted or Non-Shunted
(Double-Ended Installation)



Socket Type

Double Recessed Contact (FA8)

Shunted or Non-Shunted
(Double-Ended Installation)