

Concrete Foundation For SPP2 Speaker Post

INSTALLATION INSTRUCTIONS

The SPP2 Speaker Post requires a concrete foundation with four anchor bolts and one or more conduits embedded in it. One conduit must be installed for the audio cable. Additional conduit(s) may be required for a vehicle detection cable and/or for an AC electrical cable. These instructions are for installation of the SPP2 concrete foundation at new drive-thru sites.

CAUTION: *All electrical connections must be made by a licensed electrical contractor.*

If you have any questions regarding this installation, call HME Customer Support at 1-800-848-4468.

1.0 Equipment Provided

- 1 ea Template
- 4 ea Anchor bolt with 2 hexagonal nuts

2.0 Material Required

- Concrete, 6 cubic feet

3.0 Procedure

Step 1 Position the foundation so that water will drain away from the base of the speaker post. The top surface of the foundation must be six to ten inches above the surface of the drive-thru lane. The side of the foundation must be 2 feet or less from the side of the drive-thru lane, and parallel to the lane as shown in Figure 2.

Build a 24 x 24 inch form with its top six to ten inches above the surface of the drive-thru lane. Dig a hole in the ground to a depth 18 inches below the top of the form for pouring the concrete foundation shown in Figure 1.

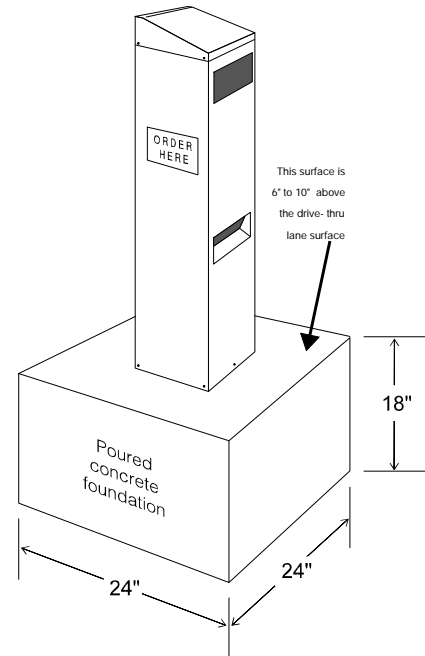

Figure 1.
SPP2 Speaker Post
on concrete foundation

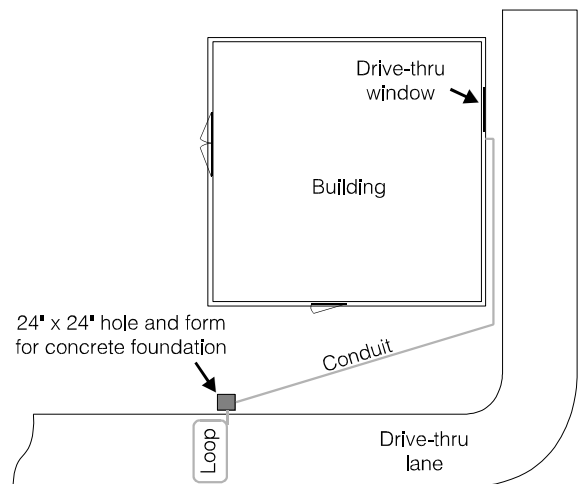

Figure 2. Typical site for concrete foundation

Step 2 Remove one of the two hexagonal nuts from each of the anchor bolts.

Be certain the second nut is all the way down to the bottom of the threaded area on the anchor bolt as shown in Figure 3.

Put the threaded end of each anchor bolt through one of the ½ inch holes in the template, and replace the nut on the anchor bolt until it holds the template snugly between the two nuts.

Position the "L" ends of the anchor bolts outward, away from each other. Place the anchor bolts into the hole in the ground with the template ¼" to ½" above the top of the form, as level as possible. Be certain to comply with the note on the template "TOWARD DRIVE-THRU LANE."

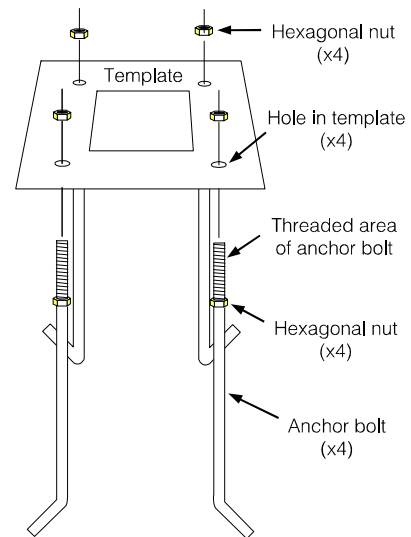

Figure 3.
Assembly of anchor bolts with template

Step 3 Route the conduit (one or more) so it/they will extend through the center of the hole, and upward approximately 6 inches through the center of the template as shown in Figure 4.

NOTE: If a loop-type vehicle detector will be used, a separate conduit must be dedicated for the loop cable.

Step 4 Hold the template steady, and fill the hole with concrete to the bottom of the template. Smooth the concrete, sloping it away from the template toward the form for proper drainage, and allow it to dry.

After the concrete has dried, remove the upper nuts and template from the anchor bolts.

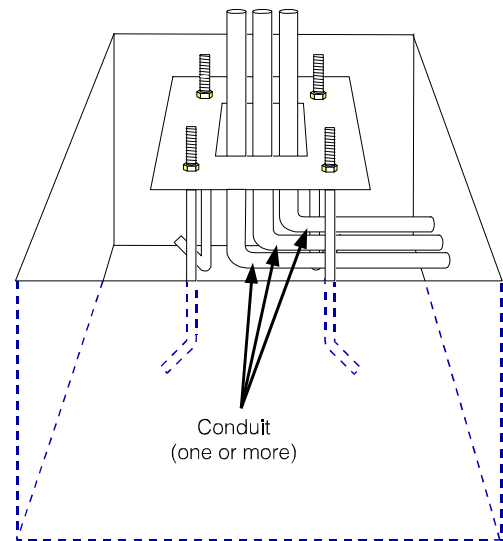

Figure 4.
Template, anchor bolt and conduit positions in hole

In the event of an electrical power outage —

such as from a lightning storm or power generator failure, if you experience problems with your HME equipment after the electricity comes on again, unplug the AC power adapters from their electrical outlets, then plug them back in.