

Pressure Manager



The all-in-one Grundfos Pressure Manager is an intelligent waterworks that controls your pump in accordance with consumption in domestic water supply and booster systems. The Pressure Manager is suitable for toilets, washing machines and outside taps. This state-of-the-art product offers benefits from innovative Grundfos features including functionality, system integration, plug-and-pump convenience and ease of use. The Pressure Manager offers a choice of two excellent models: the PM1 for basic flexibility, and the PM2 for all-round control.



FEATURES

Internal pressure tank

The Pressure Manager incorporates a small internal pressure tank which minimises the number of starts and stops of the pump in case of minor leakages.

Free position installation

The Pressure Manager can freely be installed vertically, horizontally or at an angle, if you struggle with confined spaces. Furthermore, the display can be turned 360 degrees, so it is always readable.

Integrated non-return valve

Non-return valve for backflow prevention.

PM 1 - Basic flexibility

The PM1 is suitable for applications where there is a need to start and stop the pump according to consumption. It is the basic flexibility solution, offering pump start at 1.5 or 2.2 bar. The PM1 will start the pump when the starting pressure is reached and it will keep running as long as there is flow. It provides dry-running protection and a cycling alarm for increased safety. In addition, it is suitable for use on generators.

PM 2 - All-round control

The PM2 is the all-round control solution, offering adjustable pump start at 1.5 to 5 bar. This enables customisation to different types of installation and desired comfort levels. The start pressure is set inside the unit, whereas current pressure is read on the intuitive LED display on the front of the Pressure Manager. The PM2 starts the pump when the starting pressure is reached and keeps running as long as there is flow. It is equipped with an internal pressure tank to minimise starts and stops in the event of leakage in the installation. In addition, the PM2 can be optimised for operation with a large external pressure tank by enabling the 1-bar differential pressure function. This significantly reduces the number of operating hours of the pump in installations with a pressure tank. The PM2 is also suitable for use on generators.



Pressure Manager

PRESSURE LOSS

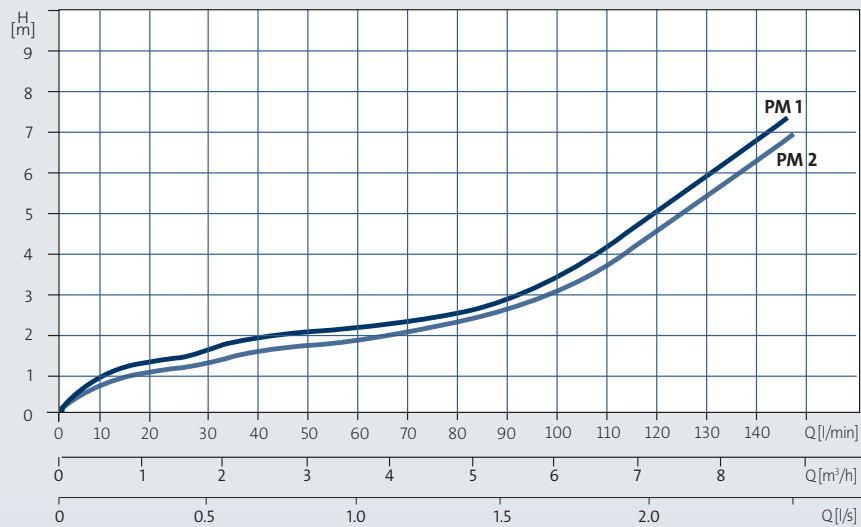

OPERATING CONDITIONS

Max. operating pressure

10 bar

Minimum flow

1.0 L/min

Liquid temperature

Max 60 °C

Ambient temperature

Max. 45 °C

Maximum humidity

95 % RH

DIMENSIONS

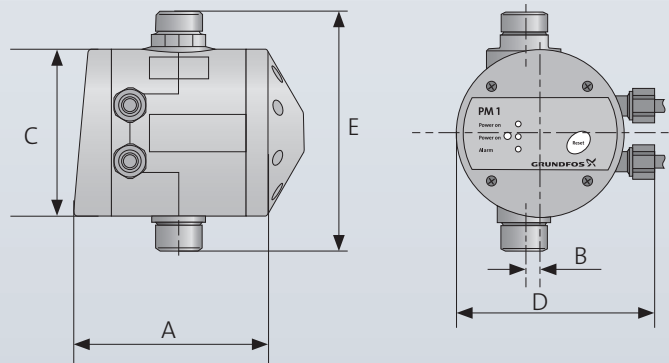

TECHNICAL DATA

Mains voltage

1 x 240 VAC, 50 Hz

Enclosure class

IP65

Sound pressure level

at 0-4 m³/h 26 dB

Volume of internal pressure tank

0.1 L

Approvals and markings

VDE, CB, C-tick, CE, GOST, RoHS, WRAS, ACS

Model	Max Current (A)	Connections		Dimensions (mm)					Q/min (Lpm)	P Start (kPa)
		Outlet	Inlet	A	B	C	D	E		
PM 1-15	6	1" M	1" M	165	12	120	143	171	1 Lpm	150
PM 1-22	6	1" M	1" M	165	12	120	143	171	1 Lpm	220
PM2	10	1" M	1" M	175	12	120	143	171	1 Lpm	150-500