

Pedrollo Automatic Peripheral Pump with Controller



The PKm60-EP1 is a high quality, clean water pressure pump suitable for use in domestic applications such as water supply to small homes and gardens.

SPECIFICATION:

- 40 metres max head
- 40 litres per minute max flow rate
- 370 W, 240 volt electric motor
- 25 mm inlet
- 25 mm outlet
- Weight 6.0 kg

The pump should be installed in a well-ventilated, enclosed environment where it is protected from inclement weather.

FEATURES:

- Pump housing in cast iron with an epoxy electro coating treatment
- Brass impeller with peripheral radial vanes
- Ceramic/Graphite/NBR mechanical seal
- 2 tap capacity
- Incorporates electronic controller with built in pressure gauge for automatic pump start/stop and crucial dry-run protection.

PUMP PERFORMANCE:

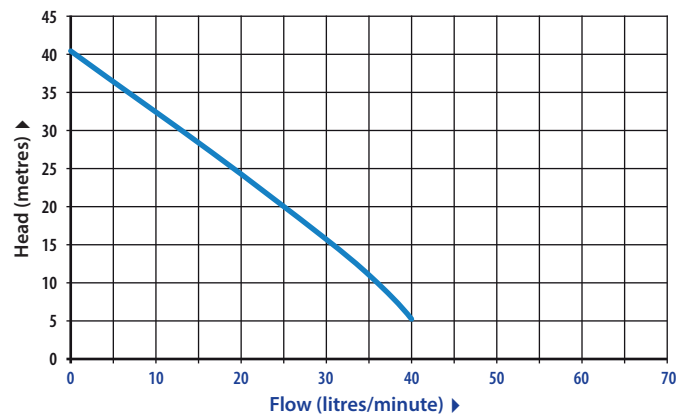

DIMENSIONS:

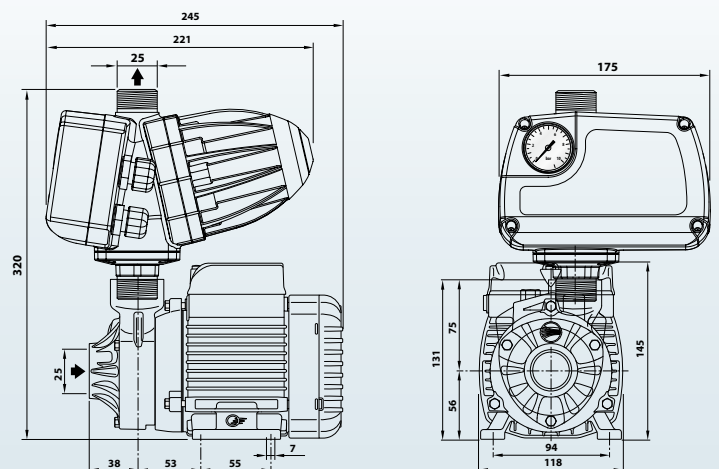

Netco Pumps reserves the right to change product specifications.