

SSS SERIES

STAINLESS STEEL CENTRIFUGAL PUMP

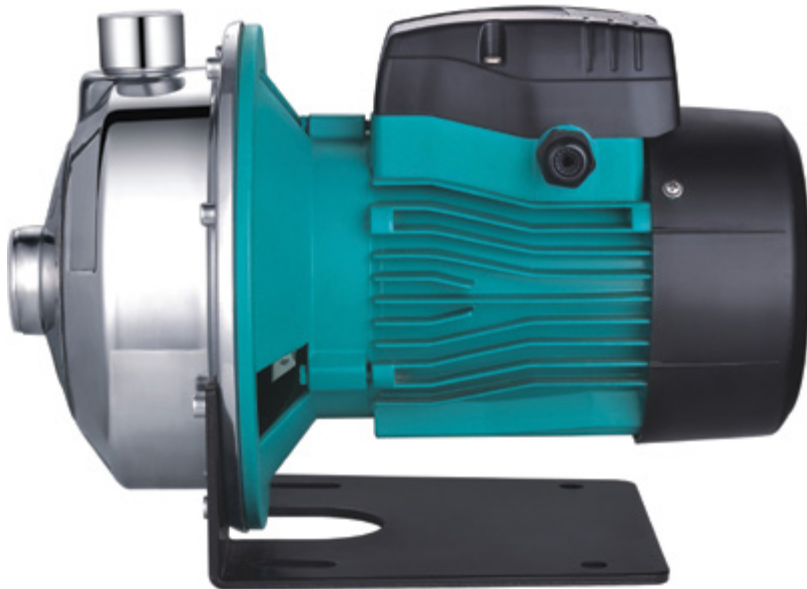

FEATURES

Easy installation and operation

Designed by Pentair with the highest quality, performance and efficiency standards, the SSS range of stainless steel pressure pumps are suitable for a range of Agricultural, Commercial and Industrial applications

Continuously Rated

Built in Thermal Protection
(only for models SSS-702, SSS-2101)

MOTOR

TEFC 2 pole motor

240V 1 Phase

Nominal speed:	2900 rpm
IP rating:	IPX4
Insulation class:	F
Frequency:	50Hz
Bearing type:	NSK

MECHANICAL SEAL

Stationary Face:	Silicon carbide
Rotating Face:	Graphite
Spring:	304 SS

APPLICATIONS

Agricultural
Commercial
Industrial
Irrigation
Water Transfer
Wash Down
Mild Chemical use*

*Viton seal kits are available for mild chemical use.

PUMP CONSTRUCTION MATERIALS

Pump Casing	304SS
Impeller	304SS
Motor Shaft	304SS
O-ring – pump casing	Nitrile

OPERATING CONDITIONS

Suitable for pumping clean, non-aggressive liquids without solids or fibres in suspension

Max. Working Pressure	10 BAR
Liquid Temp. Range	85°C
Max. Ambient Temp.	55°C

PERFORMANCE

Model	Power		l/min m ³ /h	0	30	40	60	80	100	120	140	160	180	200	250	300	350	400	430	480	520		
	kW	HP		0	1.8	2.4	3.6	4.8	6	7.2	8.4	9.6	10.8	12	15	18	21	24	26	29	31		
SSS 0702	0.55	0.75	H(m)	29.5	27.3	26.3	23.4	19.1															
SSS 2102	1.1	1.5		19.7						18.7	18.3	18.0	17.5	17.1	15.6	13.6							
SSS 2103	1.5	2.0		24.2						23.5	23.2	22.8	22.4	21.8	20.2	18.0							
SSS 3703	2.2	3.0		23.1											21.7	20.9	20.0	18.8	17.2	16.2	14.2	12.3	

ELECTRICAL

Model	Amps	Power	
		kW	HP
SSS7702	4	0.55	0.75
SSS2102	6	1.1	1.5
SSS2103	8.5	1.5	2.0
SSS3703	12	2.2	3.0

DIMENSIONS

Model	Ports		L (mm)	W (mm)	H (mm)	L ₁ (mm)	L ₂ (mm)	W ₁ (mm)	H ₁ (mm)
	DN1	DN2							
SSS 0702	1¼	1	332	210	224	119	55	149	110
SSS 2102	1½	1¼	440	210	250	129	55	149	110
SSS 2103	1½	1¼	440	210	250	129	55	149	110
SSS 3703	2	1¼	440	210	250	129	55	149	110

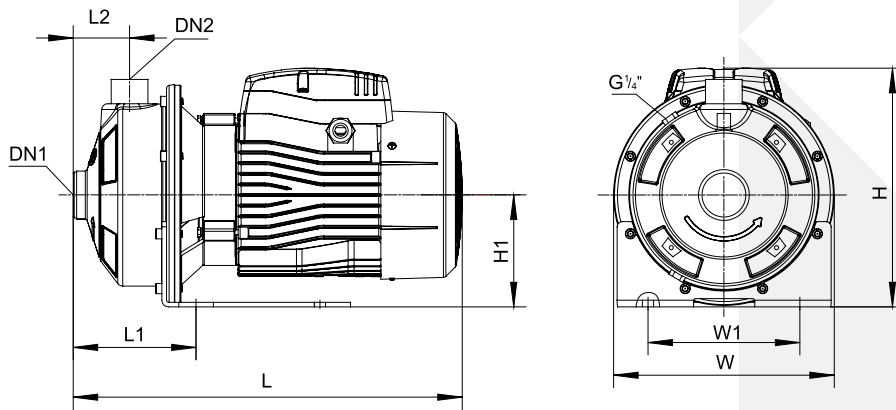

HYDRAULIC PERFORMANCE CURVE

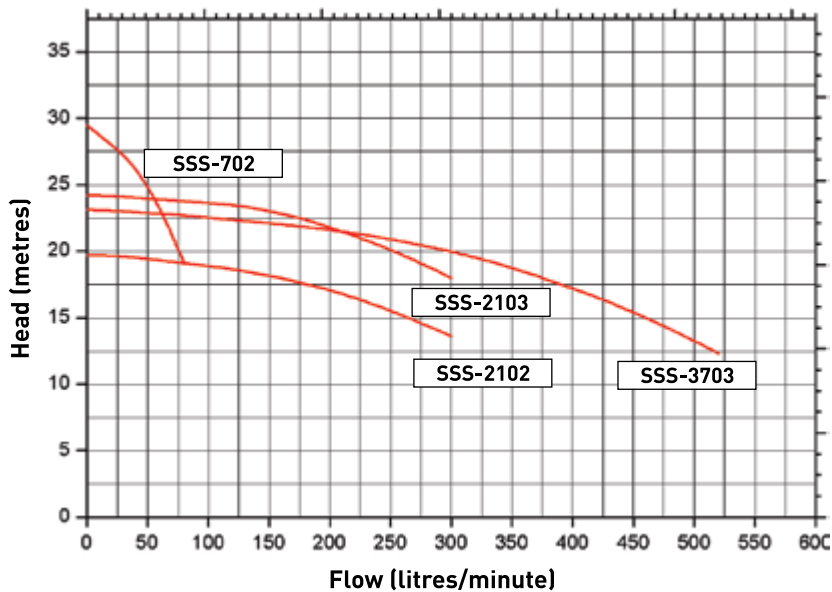

Head Office Pentair AU/NZ: 1-21 Monash Drive, Dandenong South, VIC 3175, Australia. www.pentair.com.au

All Pentair trademarks and logos are owned by Pentair, Ltd. All other brand or product names are trademarks or registered marks of their respective owners. Because we are continuously improving our products and services, Pentair reserves the right to change specifications without prior notice.

Pentair is an equal opportunity employer.

ABN 27 004 856 204 © 2012 Pentair, Ltd. All Rights Reserved.

© 2014 Pentair

L100234A 0414