

FIREFIGHTER® PRO

Model Numbers: 5190BE, 5190HE,
5113BE & 5113HE

DEPEND ON
DAVEY

WATER PRODUCTS



SELF PRIMING PUMPS

PRODUCT DESCRIPTION

Rugged, economical, single impeller, self priming pump. These units are driven by either a 296cc or 391cc Briggs & Stratton "Vanguard" engine or a 270cc or 389cc Honda GX/E engine, fitted with an electric start.

APPLICATIONS

- Firefighting
- Tanker to tanker water transfer
- High head general water transfer
- Sheep jetting
- Irrigation
- Boom spraying
- Travelling irrigators

FEATURES & BENEFITS

Heavy duty wide vane impeller for longer life, improved performance and easier cleaning in the case of blockage.

Single impeller design provides the versatility of high flow rates with strong pressure.

Thrust balanced impeller design to extend engine life.

Pump casing, diffusers and impellers manufactured from quality corrosion resistant marine grade aluminium for long life.

NEW 3 way discharge port for easy installation with a choice of plumbing sizes. The NEW 3 way discharge is easily adapted to the old 3 way outlets.

Polyester coated pump casing, exterior and interior, for added corrosion resistance.

Self priming from up to 6m for more versatile installation options.

Patented floating impeller neckrings front and back. The front neckring helps improve pumping efficiency, the back neckring helps extend seal life and dramatically reduce engine wear.

Huge 1½" priming port for extra quick filling.

Large drain port with bayonet fit plugs. Plugs have safety retention system.

Low-oil protection on all models - engines won't start or run if oil level is inadequate, thus protecting your engine.

All engines feature cast iron cylinder bore for long life.

Electric starter (12Vac 30Amp hour battery and leads required) and recoil starter fitted, ensures a choice of starting methods, even if the battery is flat or removed.

Viton seal and oring kit available for herbicide/insecticide spraying.

OPERATING LIMITS

Flows to	900lpm
Maximum total head	54m
Maximum suction Lift	6m
Maximum water temperature	50°C
Minimum water temperature	1°C
Minimum suction pipe size	2"
Suction pipe strainer	Required
Inlet size	2" BSP(M)*
Outlet sizes	1 x 2" BSP(M)• 2 x 1" BSP(M)•
Priming port	1 x 1½" BSP(M)*

* NPT thread available on request.

- 1x1½" & 2x1" NPT outlet tee available on request.



TECHNICAL SPECIFICATIONS

MATERIALS OF CONSTRUCTION

PART	MATERIAL
Suction cover	Marine grade aluminium (AS605)
Diffuser	Marine grade aluminium (AS605)
Impeller	Marine grade aluminium (AS605)
Casing / yoke	Marine grade aluminium (AS605)
Mechanical seal	Carbon / ceramic
3 way discharge	Marine grade aluminium (AS605)
Casing bolts	Zinc plated steel
Yoke bolts	Stainless steel
Flap valve / seal ring	Zinc body, Hytrel seal
Neck ring, priming & drain plug	Glass filled Nylon
Casing, priming & drain plug oring	Nitrile rubber
Discharge gasket	Hytrel
Paint finish	Baked polyester powder coat

ENGINE SPECIFICATIONS

Engine Brand	Briggs & Stratton	Honda	Briggs & Stratton	Honda
Engine Model	Vanguard	GX270E	Vanguard	GX390E
Single Stage Pump Model	5190BE	5190HE	5113BE	5113HE
"Out of box" governed max engine speed @ no load	4200rpm	3800rpm	4200rpm	3800rpm
Displacement (cc)	296	270	391	389
Fuel Tank (litres)	6.0	6.0	7.9	6.5
Approx. fuel consumption @ full load @ 3600rpm	3.16	3.05	4.68	3.25
Running time per tank @ full load @ 3600rpm	1.9	1.9	1.7	2.0
Oil Capacity (litres)	1.4	1.1	1.5	1.1
Spark arrestor	Yes			
dBa @ 3600rpm @ full load	79 @ 4m	79 @ 7m	81.5 @ 4m	78 @ 7m

INSTALLATION & PRIMING

- Fit strainer to bottom of suction pipe; a foot valve is not required
- To prime, fill pump body with water then allow pump to run until drawing water

This literature is not a complete guide to product usage. Further information is available from your Davey dealer, Davey Customer Service Centre and from the relevant product Installation and Operating Instructions. This data sheet must be read in conjunction with the relevant product Installation and Operating Instructions and all applicable statutory requirements. Product specifications may change without notice.

© Davey and Firefighter are registered trademarks of Davey Water Products Pty Ltd. © Davey Water Products Pty Ltd 2005.

DEPEND ON
DAVEY

WATER PRODUCTS

Davey Water Products Pty Ltd

Member of the GUD Group
ABN 18 066 327 517
Head Office and Manufacturing
 6 Lakeview Drive,
 Scoresby, Australia 3179
 Ph: +61 3 9730 9222
 Fax: +61 3 9753 4100
 Website: davey.com.au
Customer Service Centre
 Ph: 1300 367 866
 Fax: 1300 369 119
 E-mail: sales@davey.com.au
Interstate Offices
 Sydney • Brisbane • Adelaide
 Perth • Townsville

International

6 Lakeview Drive,
 Scoresby, Australia 3179
 Ph: +61 3 9730 9121
 Fax: +61 3 9753 4248
 E-mail: export@davey.com.au

Germany

Kantstrasse 53,
 04275 Leipzig
 Ph: +49 341 301 0412
 Fax: +49 341 301 0413
 E-mail: akrenz@daveyeurope.com

New Zealand

7 Rockridge Avenue,
 Penrose, Auckland 1330
 Ph: +64 9 570 9135
 Fax: +64 9 527 7654
 Website: daveynz.co.nz
 E-mail: sales@daveynz.co.nz

USA - Davey Pumps Inc.

1005 N. Commons Drive
 Aurora, Illinois 60504
 Ph: +1 630 898 6976
 Fax: +1 630 851 7744
 Website: daveyusa.com
 E-mail: sales@daveyusa.com

HYDRAULIC PERFORMANCE

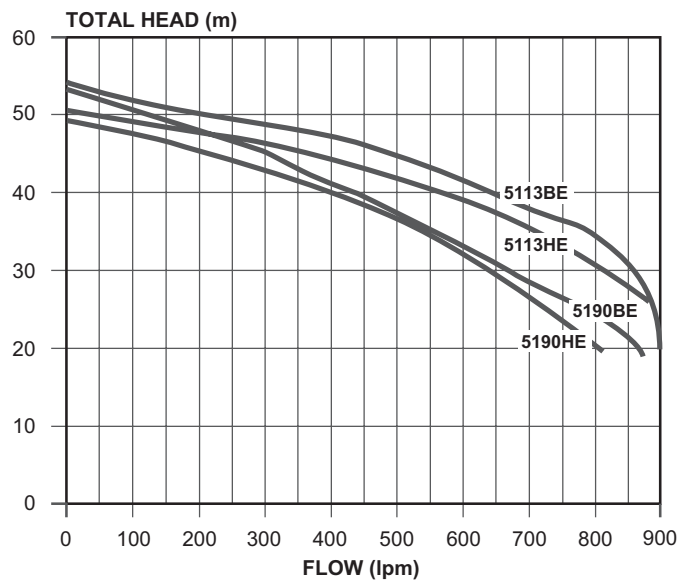

DIMENSIONS

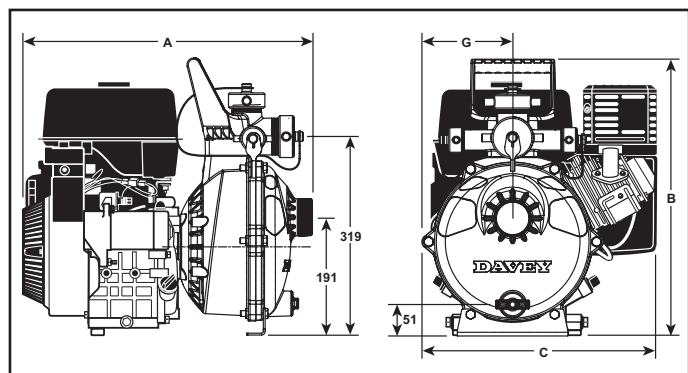

Model	A	B	C	G	* Inlet BSP	• Outlet BSP	* Priming Port BSP	Dry Weight (kg)
5190BE	523	450	427	156	2"	2 x 1" 1 x 2"	1 1/2"	35.6
5190HE	507	450	435	155	2"	2 x 1" 1 x 2"	1 1/2"	27.2
5113BE	547	476	457	171	2"	2 x 1" 1 x 2"	1 1/2"	41.5
5113HE	532	445	455	161	2"	2 x 1" 1 x 2"	1 1/2"	33.5

*NPT thread available on request.

•1 1/2"x1" & 1"x2" NPT outlet tee available on request.

All dimensions in mm unless otherwise stated.



Visit Davey on-line for further information
davey.com.au