



Depend on Davey

**DAVEY**

## APPLICATIONS

- Dirty water pumping
- Sump emptying
- Septic effluent water disposal
- Pumping of waste water with small soft solids in suspensions
- Pumping in partially submerged application



## Davey Sump Pump

Model Numbers: DCS40A, DCS40M, DCS55A, DCS55M, DCS75A, DCS75M & DCS150

Stainless steel shell, double cased submersible dewatering sump pump.

## WHY CHOOSE THE Davey Submersible Dewatering Pump Systems?

Davey Sump Pumps are used to remove water that has accumulated in a sump or pit, as well as emptying swimming pools and removing flood water from buildings etc.

Davey Sump Pumps are used where there is flooding and to solve water entry in basements where the water table is above the foundation.

Open impeller, semi-vortex, centrifugal design

- Able to pump small soft solids in suspension
- Less susceptible to blockage

Double mechanical shaft seal in oil bath with hard faced silicon carbide/ceramic seal on pump side

- Added motor protection
- Long service life

Sand slinger lip seal

- Added protection
- Long service life

Corrosive resistant 304 stainless steel outer case and strainer

- Long service life
- Attractive, lasting appearance

Double case with full discharge flow past internal motor shell

- Able to operate in partially submerged installations
- Better motor cooling for longer life

Automatic resetting thermal overload

- Protects against overloading

In-built automatic thermal overload

- Protects the motor in the event of blockage or voltage supply problems

HO7RNF oil resistant leads, 10 metres long with 3 pin power plug

- Easy to connect to power supply
- Longer life in dirty water

**MATERIALS OF CONSTRUCTION**

Part	Material
Impeller	Cast iron
Suction interest	304 stainless steel
Outer casing	304 stainless steel
Pump casing	Cast iron
Shaft seal – pump side – motor side	Silicon carbide/ceramic Carbon/ceramic - mechanical seal in captive oil bath with oil seal
Shaft seal elastomer	Nitrile rubber
Pump shaft	304 stainless steel
Orings	Nitrile rubber
Motor shell	304 stainless steel
Handle	304 stainless steel
Fasteners	304 stainless steel
Float and power supply leads	HO7RN-F oil resistant

**ELECTRICAL DATA**

Electrical Lead	HO7RNF x 10m length
Speed	2 pole, 2850rpm
Insulation class	Class F
IP rating	X8
Starting	CSIR

**Suitable Fluids:**

Sewage or "grey water" of neutral pH containing up to 10% of small soft organic solids (<10mm OD). Some accelerated wear should be expected while pumping hard solids in suspension.

**OPERATING LIMITS**

Model	DCS40A DCS40M	DCS55A DCS55M	DCS75A DCS75M	DCS150
Supply voltage (V)	220-240V			
50Hz – Phase	Single			
Output power (kW)	0.4kW	0.55kW	0.75kW	1.50kW
Full Load Current (A)	2.70A	4.00A	7.50A	13.00A
Locked rotor current (A)	8.5A	13A	22.50A	48.00A

**INSTALLATION & PRIMING**

Use a rope to position and retrieve the pump. Do not lower or retrieve the pump using the power lead as this may damage the cable entry seals, causing water leaks and unsafe operation.

Don't use this product for recirculating or filtering swimming pools, spas, etc. While these pumps are built to high safety standards, they are not approved for installations where people will be in the water while they are operating.

Don't pump abrasive materials. Sand and grit in the water being pumped will accelerate wear, causing shortened pump life.

Keep your pump clean, particularly in situations where lint, hair or fibrous materials may get bound around the pump shaft. Regular inspection and cleaning will extend pump life.

Make room for the float switch to operate. Automatic models have a float switch to turn them on when the water level rises and turn them off again when it has been pumped down to the safe operating level of the pump. If the float switch is not free to rise and fall, correct pump operation may not be possible.

Don't run your pump dry. Non-automatic models must be switched off manually or by way of an external float/level switch when the water level is reduced to the top of the pump housing.

**DIMENSIONS (mm)**

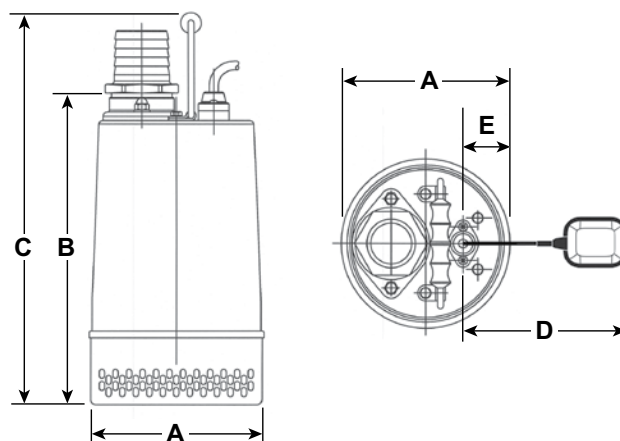

Model	A (mm)	B (mm)	C (mm)	D* (mm)	E* (mm)	Outlet B.S.P.	Net Weight (kg)
DCS40A DCS40M	167	280	370	320	45	2" F	14
DCS55A DCS55M	192	340	430	580	53	2" F	25
DCS75A DCS75M	192	340	430	580	57	2" F	25
DCS150	182	441	531	-	-	2" F	26

\*Applicable for A models only.

**HYDRAULIC PERFORMANCE**

