

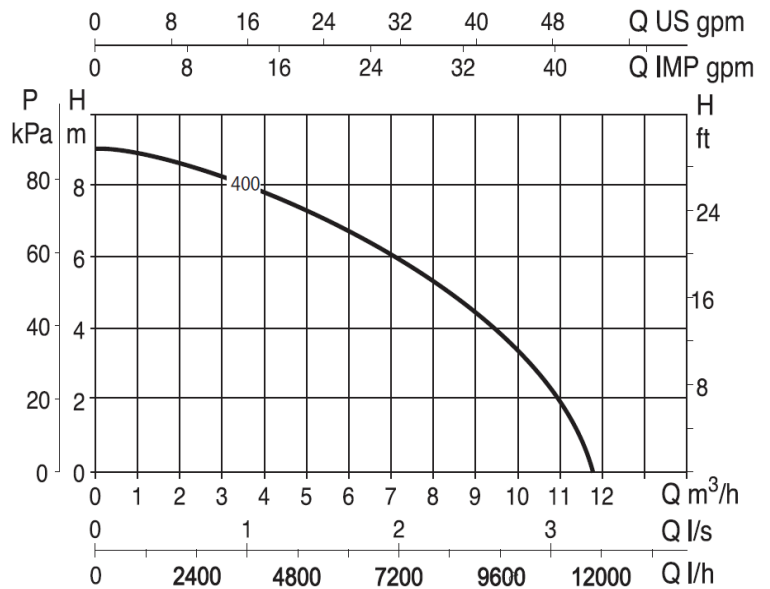

- Submersible pumps specifically designed for use in narrow pits with dimensions down to 20cm x 20cm.
- Suitable to pump clear water containing particles with maximum diameter up to 5mm.
- Pump with built-in float switch, 10m power cable. Anti-corrosive and rust-proof materials. Low suction capability: 2-3mm (manual mode).
- A pump priming limit: 10-15mm (manual mode).
- Lever for manual or automatic operation. Easy access through sliding cover to float switch for cleaning.
- Excellent cooling of the motor than enables the pump to operate even when it is partially submersible.
- Supplied with power cable with plug, non return valve and 4-step fitting.

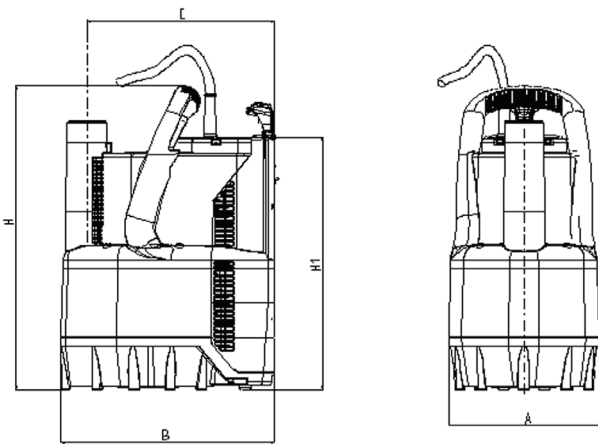

Model	A	B	C	H	HI	DNM GAS	PACKING DIMENSIONS		
							L/A	L/B	H
VERTY NOVA 400 M	158	225	200	354	301	1 1/4"	222	193	340

Liquid:		Electrical Data:	
Liquid Type:	Clear Water	Rated Voltage:	240V
Solid Handling:	5mm Ø	Rated Output:	0.4kW
Liquid Temperature Range:	0 - 35 °C	Power:	0.55 HP
		Mains Frequency:	50 Hz
Materials:		Current:	2.6 A
Pump Body:	Technopolymer	Capacitor:	10 µF
Impeller:	Noryl	Motor Duty:	Continuous
Elastomers:	Nitrile	Motor Type:	Asynchronous
Rotor/Shaft:	416 Stainless Steel	Motor Protection:	Built-in Thermal Overload
		Ingress Protection:	IP 68
Installation:		Insulation Class:	Class F
Max Ambient Temperature:	40 °C	Power cable length:	10m
Discharge Size/Pipe Connection:	1 1/4" M BSP	Hydraulic Data:	
Net weight:	5.1 kg	Max Flow (l/min):	180
Dimensions (mm):	H 354 X W 225 X 158	Max Head (m):	9

