

Aquaplus

**SDB Series
Heavy Duty Submersible
Dewatering Pumps
240V**



Dewatering Pumps

**3 Year
Warranty!**

Heavy Duty Submersible Dewatering Pumps 240V

Aquaplug SDB 240V pumps are small robust dewatering pumps ideal for professional use in applications such as construction sites and site drainage. SDB pumps are designed for continuous unattended operation. Manual and automatic (with float) versions are available.

Features

- Single phase 240V pump
- Small robust pump
- Abrasion resistant pump casing
- Automatic motor protection
- Double mechanical seal in oil bath
- Stainless steel frame
- Bottomer version available, pumps down to 2mm

Applications

- Construction site dewatering
- Cellar or basement drainage
- Storm water drainage
- Decorative water features and fountains
- Tank, swimming pool, pond pump out

Specifications

Model Number	Discharge (mm)	Power (kW)	Voltage (V)	Cable (m)	Max Flow (L/s)	Shut-off Head (m)	Pump Weight (kg)	Max Solid (mm)	Rated current A (240 V)
Manual									
SDB-50-56-.4S2-10MP-V	50	0.4	240	10	3.6	12	12	7	2.6
SDB-50-56-.75S2-10MP-V	50/80	0.75	240	10	5	14	14	7	4.6
SDB-50-56-.4S2-10MP-VB	50	0.4	240	10	2	12	12	3	2.6
Automatic									
SDB-50-56-.4S2-10AP-V	50	0.4	240	10	3.6	12	12	7	2.6
SDB-50-56-.75S2-10AP-V	50/80	0.75	240	10	5	14	14	7	4.6

Dimensions

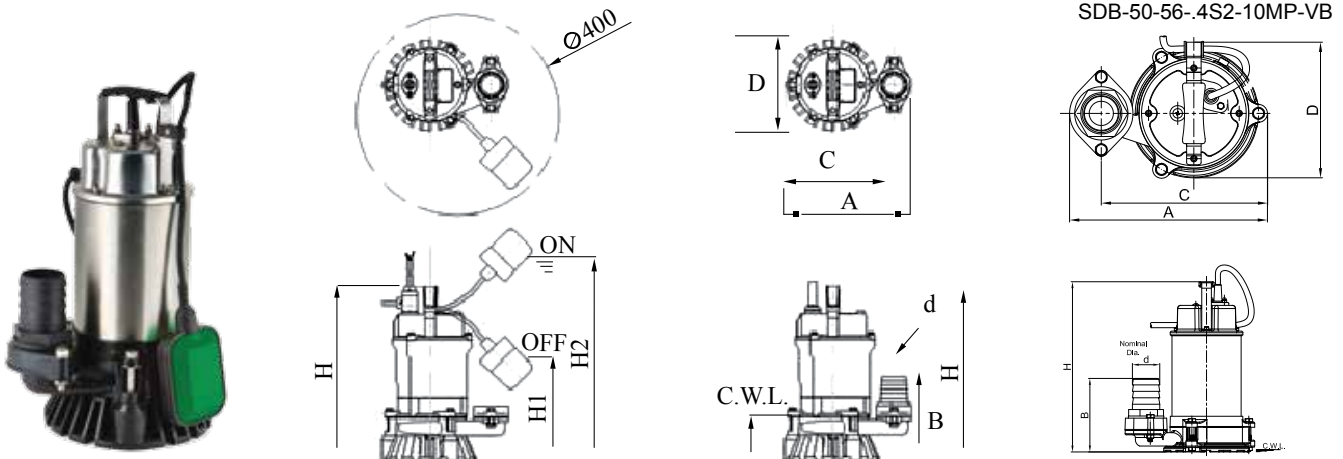

Model	Dimensions (mm)								
	D	H	A	B	C	H1	H2	d	C.W.L
Manual									
SDB-50-56-.4S2-10MP-V	185	400	241	170	207	n/a	n/a	50	90
SDB-50-56-.75S2-10MP-V	184	410	285	217	233	n/a	n/a	80	90
SDB-50-56-.4S2-10MP-VB	182	317	245	137	205.5	n/a	n/a	n/a	5
Automatic									
SDB-50-56-.4S2-10AP-V	185	400	241	170	207	170	400	50	90
SDB-50-56-.75S2-10AP-V	184	410	285	217	233	170	400	80	90

All content is subject to change without notice.

Performance Curves

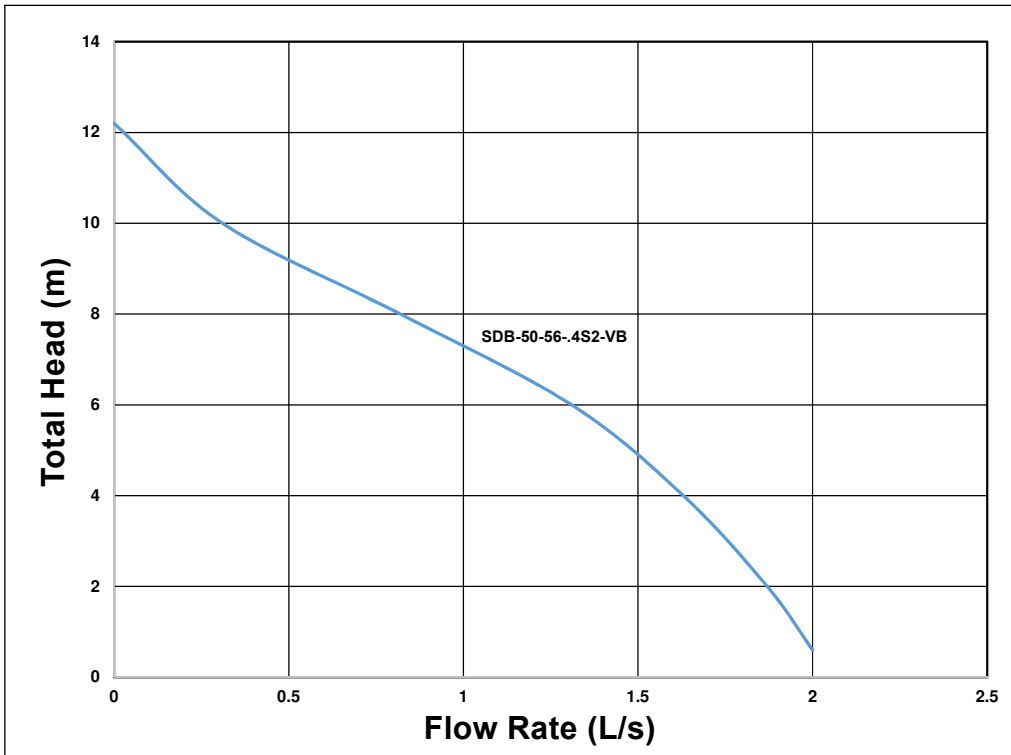
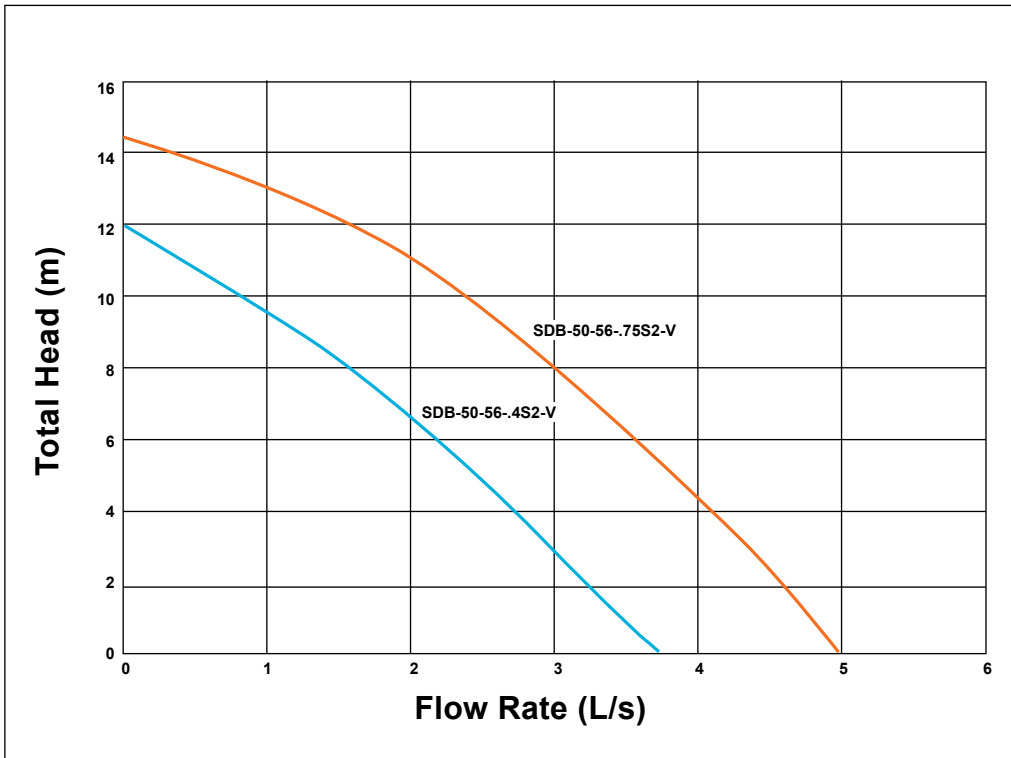

All content is subject to change without notice.

Aquaplus Product Range

ESD Series – End Suction DIN (24255) Pumps

ESI Series – End Suction ISO (2585) Pumps

SP Series – Self Priming Pumps

SD Series – Submersible Dewatering Pumps

AD Series – Air Diaphragm Pumps

MD Series – Magnetic Drive Pumps

FRM Series – Flexible Rising Main (Borehole Pump Hose)

MS Series – Mechanical Seals (Single Spring & Cartridge)

We are also able to provide Progressive Cavity, Peristaltic Pumps, Split Case Pumps and Magnetic Drive Pumps.

The logo for Aquaplus, featuring the word "aquaplus" in a stylized, blue, lowercase font with a wave-like graphic element above the 'a'.

AVAILABLE FROM

For information on these products or for any specialised requirements please contact your local Aquaplus distributor or visit our website at www.aquapluspumps.com.au