

APG.50.65.3 50 Hz

General description

APG pumps are submersible pumps with horizontal discharge port, specifically designed for the pressurized pumping of:

- sewage,
 - wastewater containing destructible solids.
- APG pumps are equipped with a cutter system which cuts destructible solids into small pieces so that they can be led away through pipes of a relatively small diameter.

The compact design makes APG pumps suitable for both temporary and permanent installation.

Furthermore, APG pumps are suitable for free-standing installation as well as installation by means of an auto-coupling guide rail system.

APG pumps are supplied with 10 metres of cable.

APG pumps are available with or without control box and level switch.

Pumps without control box must be connected to a separate pump controller with motor starter.

Technical data

	Voltage [V]	I_n [A]	I_{start} [A]	$\cos \varphi$	Product number
Standard	3 x 400	13.4	71	0.81	96835728

- P1: 7.5 kW
- P2: 6.5 kW
- Mains: 50 Hz, 3-phase
- Enclosure class: IP 68
- Insulation class: F (155 °C)
- Speed: 2900 min⁻¹
- Solids passage: Cutter system
- Discharge diameter: DN 50
- Overall efficiency: 34 %
- Hydraulic efficiency: 39 %
- pH-range: 4-10
- Temperature range: 0-40 °C
- Maximum installation depth: 10 m
- Starts per hour: Max. 20
- Maximum density of liquid: 1100 kg/m³
- Weight including cable: 104 kg

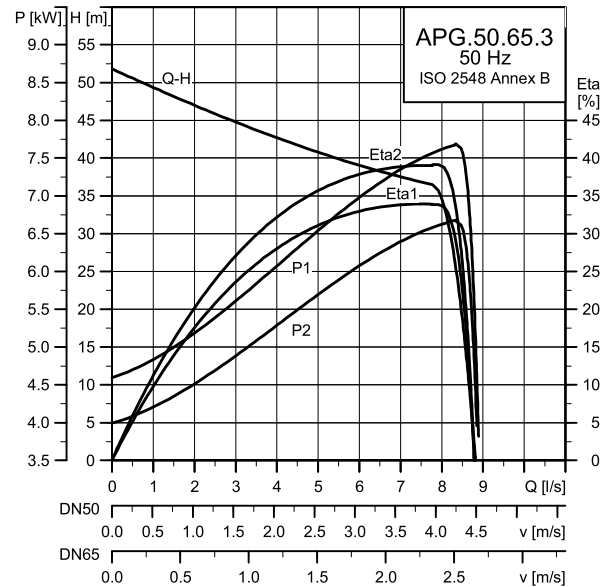

Material specification

Component	Material	DIN W.-Nr.	AISI/ASTM
Stator housing	Cast iron GG 25	0.6025	ASTM 35.B
Motor cable	Standard version: H07RNF		
Pump housing	Cast iron GG 25	0.6025	ASTM 35.B
Impeller	Cast iron GG 25	0.6025	ASTM 35.B
Shaft	Chromium steel	1.4104	AISI 430 F
Cutter system	Hardened steel		
Wear plate	Cast iron GG 25	0.6025	ASTM 35.B
Bearings	Heavy-duty prelubricated ball bearings		
Screws	Stainless steel	1.4301	AISI 304
Shaft seals	Two mechanical bellows seals: Silicon carbide/silicon carbide		
Oil	Shell Ondina 15, non-toxic Oil chamber: 1.7 litres		

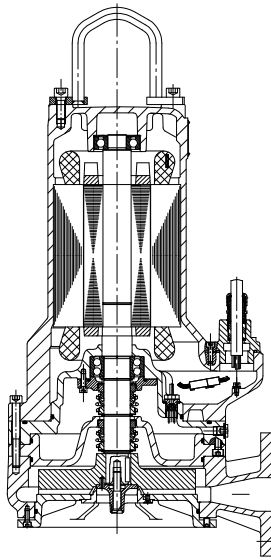

TM05 1633 3311

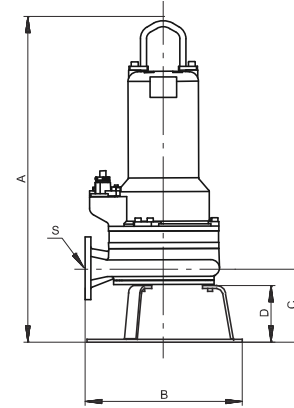

TM05 1634 3311

Dimensions [mm]

A	B	C	D	S
792	415	193	150	DN 50

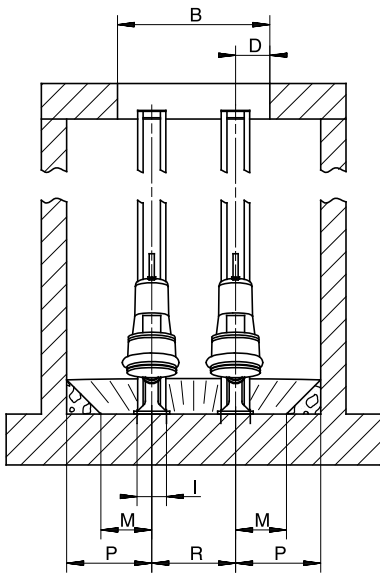

TM01 2607 2098

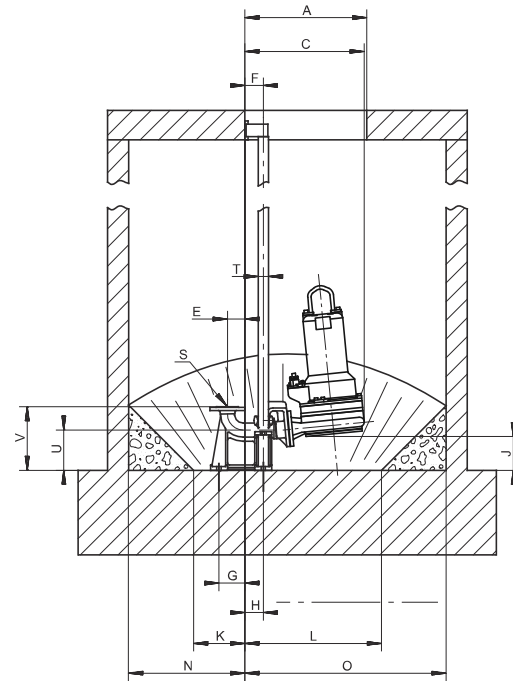

TM05 1635 3311

Two-pump installation on auto-coupling

A	B	C	D	E	F	G	I	J	K	L	M	N	O	P	R	S	T	U	V
600	1300	563	340	83	87	123	270	159	243	645	200	800	1200	690	620	DN 50	1½"	190	300

One-pump installation on auto-coupling

A	B	C	D	E	F	G	I	J	K	L	M	N	O	P	S	T	U	V
600	600	563	300	83	87	123	270	159	243	645	200	550	950	750	DN 50	1½"	190	300

99784981 1119
ECM: 1272164