



Depend on Davey

DAVEY

APPLICATIONS

- Seawater
- Brackish water
- Light brines
- Water supply
- Water transfer
- Hosing down – dairies, factory floors, etc.
- Tank filling
- Sprinkler supply
- Garden reticulation



Dynaflo 6000 Series

6220SS & 6230SS

Single Stage Pump

Model Numbers:

62201SS, 62203SS & 62303SS

Rugged single stage centrifugal pumps with cast 316SS pump casing and silicon carbide hard faced mechanical seal are specifically designed to pump seawater, brackish water and light brines.

WHY CHOOSE THE Davey Dynaflo Single Stage Pump?

Every pump is performance and pressure tested in our factory to ensure quality and reliability.

Cast 316SS pump casing with silicon carbide hard faced mechanical seal for long life.

O-ring sealed hand tightened priming plugs for easy operation.

Proven, robust pump design for long life.

316 stainless steel pump shaft for longer life in aggressive water.

Davey manufactured motor with IP56-TEFC, 2 pole motor is corrosion resistant for long term protection against vermin, dust and water.

Motor and pump are designed for frequent starts providing a long and reliable working life.

In-built thermal overload protection with automatic reset in all single phase models for long term motor protection.

Double contact seal, C3, high temperature greased bearings for long life and smooth running.

2m power lead with 15amp Australian three pin plug fitted to all single phase models.

Single phase 62201SS model is suitable for both 220-240 Volt and 440-480 Volt single phase supply.

Corrosion resistant motor mounting feet for long life.

OPERATING LIMITS		
Type	6220SS	6230SS
Capacities to	350 lpm	440 lpm
Maximum total head	38m	40m
Maximum suction head	7.0m	
Maximum water temperature	50°C	
Minimum water temperature	1°C	
Inlet size	2" BSP(F)	
Outlet size	1½" BSP(F)	
Maximum casing pressure	105m	

MATERIALS OF CONSTRUCTION	
Part	Material
Impellers	Glass filled polycarbonate
Impeller locknut	ZF brass
Pump casing	Cast 316SS
Seal ring (stationary)	Silicon carbide
Seal ring (rotating)	Silicon carbide
Shaft	316SS
Seal elastomer	Nitrile rubber
Pump orings	Nitrile rubber
Motor shell	Aluminium
Pump casing/shell finish	Baked enamel
Motor mounting feet	Xenoy plastic
Motor through bolts	304 s/s with brass nuts
Motor fan	Polypropylene

INSTALLATION & PRIMING
<ul style="list-style-type: none"> Installation with suction lift require a good quality foot valve to avoid loss of prime. To prime, fill pump body and suction line through priming plug hole located above suction inlet and replace plug.

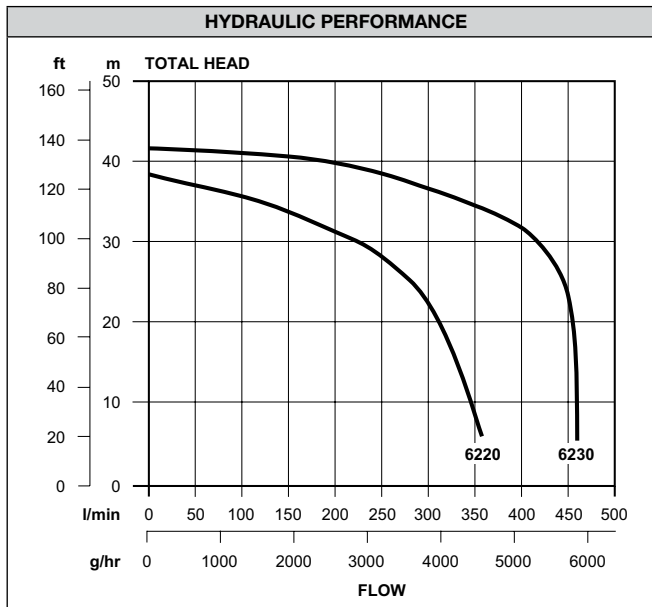

ELECTRICAL DATA				
	6220SS			6230SS
Supply voltage	220-240	440-480	380-415	380-415
Supply frequency	50Hz			
Phase	Single		Three	
Full load current	14A	7A	4.7A	6.3A
Locked rotor current	54A	27A	24A	47A
Input power	3.2kW	3.2kW	2.8kW	3.9kW
Output power	2.4kW	2.4kW	2.4kW	3.0kW
Insulation	Class F			
Starting	P.S.C.		N/A	
IP rating	IP56			

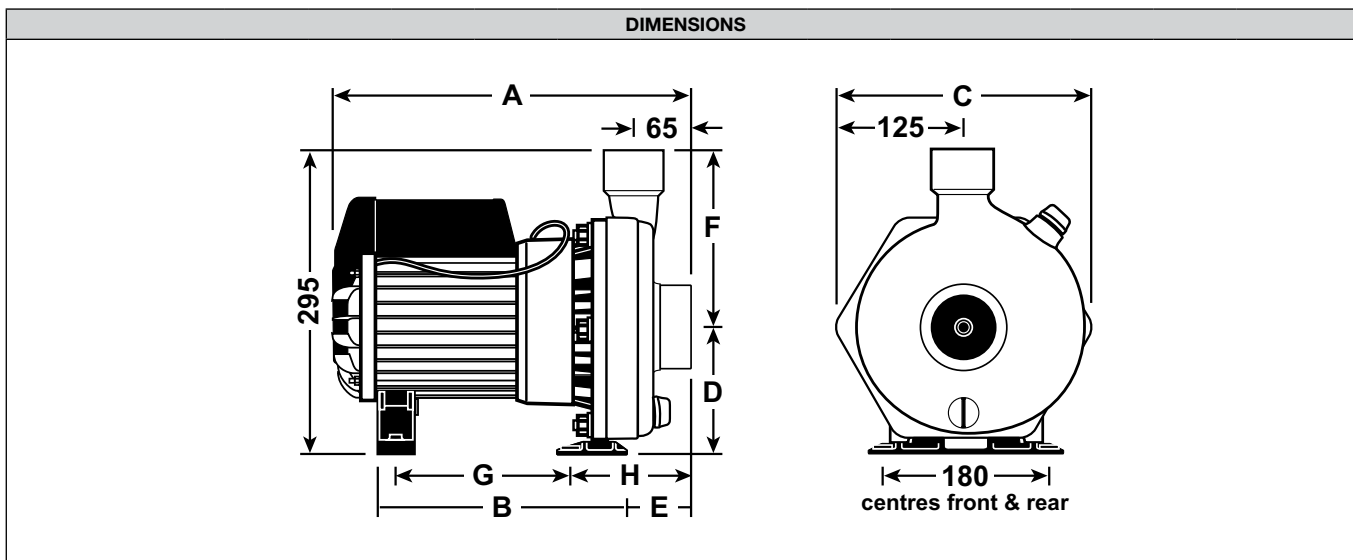

Type	A	B	C	D	E	F	G	H	Mounting holes diameter (mm)	Inlet B.S.P.	Outlet B.S.P.	Net Weight (kg)
62201SS	415	280	250	125	70	175	223	130	10	2" F	1 1/2" F	32
62203SS	385	250	250	125	70	175	223	130	10	2" F	1 1/2" F	28.5
62303SS	455	320	250	125	70	175	233	130	10	2" F	1 1/2" F	33

All dimensions in mm unless otherwise stated.



davey.com.au | daveynz.co.nz

This literature is not a complete guide to product usage. Further information is available from your Davey Dealer, Davey Support Centre and from the relevant product Installation and Operating Instructions. Must be read in conjunction with the relevant product Installation and Operating Instructions and all applicable statutory requirements. Product specifications may change without notice.
 © Davey is a registered trademark of Davey Water Products Pty Ltd. © Davey Water Products Pty Ltd 2016.