

FRAME DIMENSIONS AND FOOT PRINT

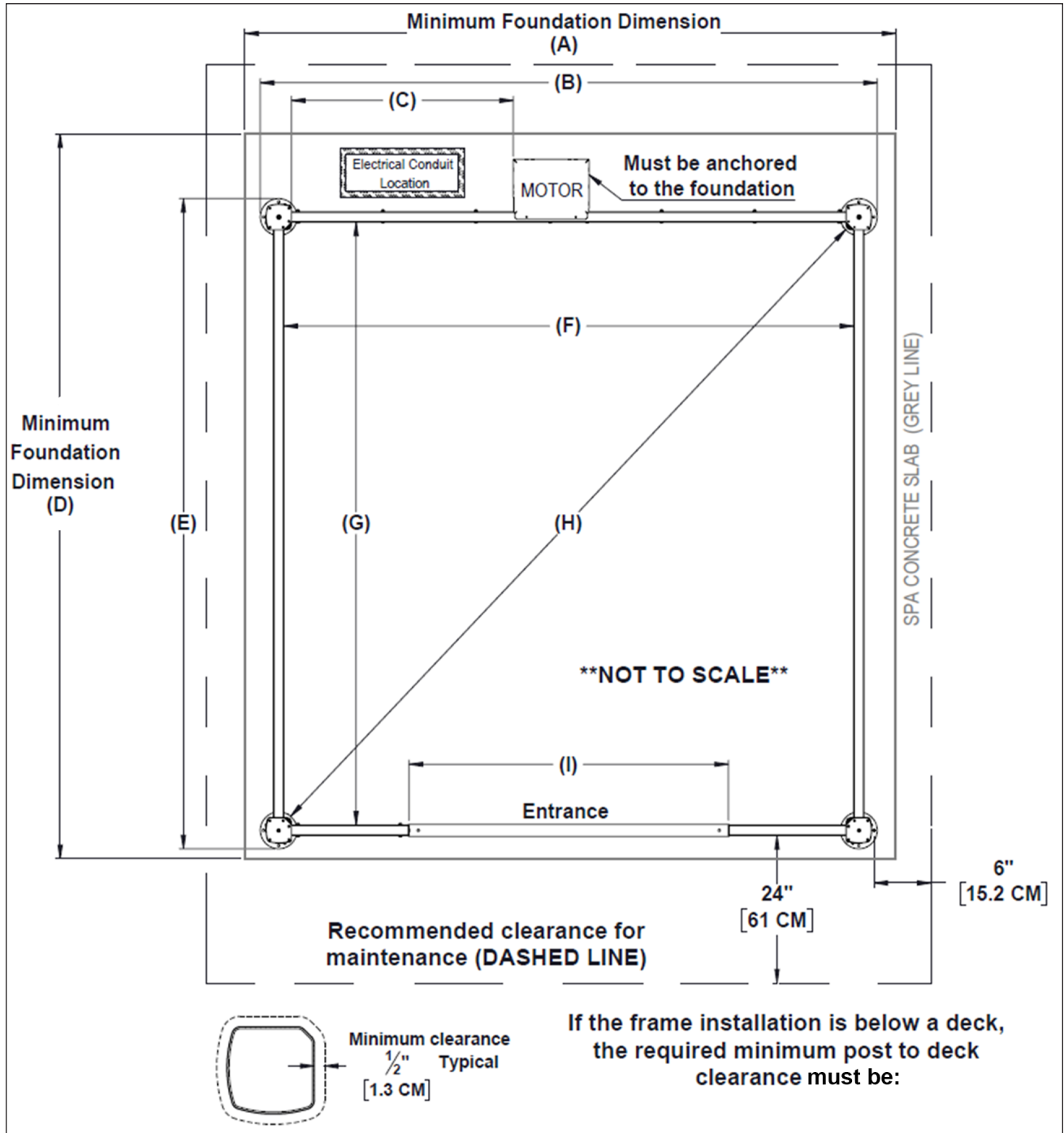

INCH (mm)	A	B	C	D	E	F	G	H	I
STANDARD MODEL	106 (2692)	100.5 (2553)	35 (889)	118 (2297)	105.75 (2685)	92.75 (2356)	98 (2489)	130.75 (3321)	52 (1321)
LONG SIDE MODEL	112 (2845)	105.75 (2685)	39 (991)	113 (2870)	100.5 (2553)	98 (2489)	92.75 (2356)	130.75 (3321)	57 (1448)

CONCRETE SLAB LAYOUT OPTION

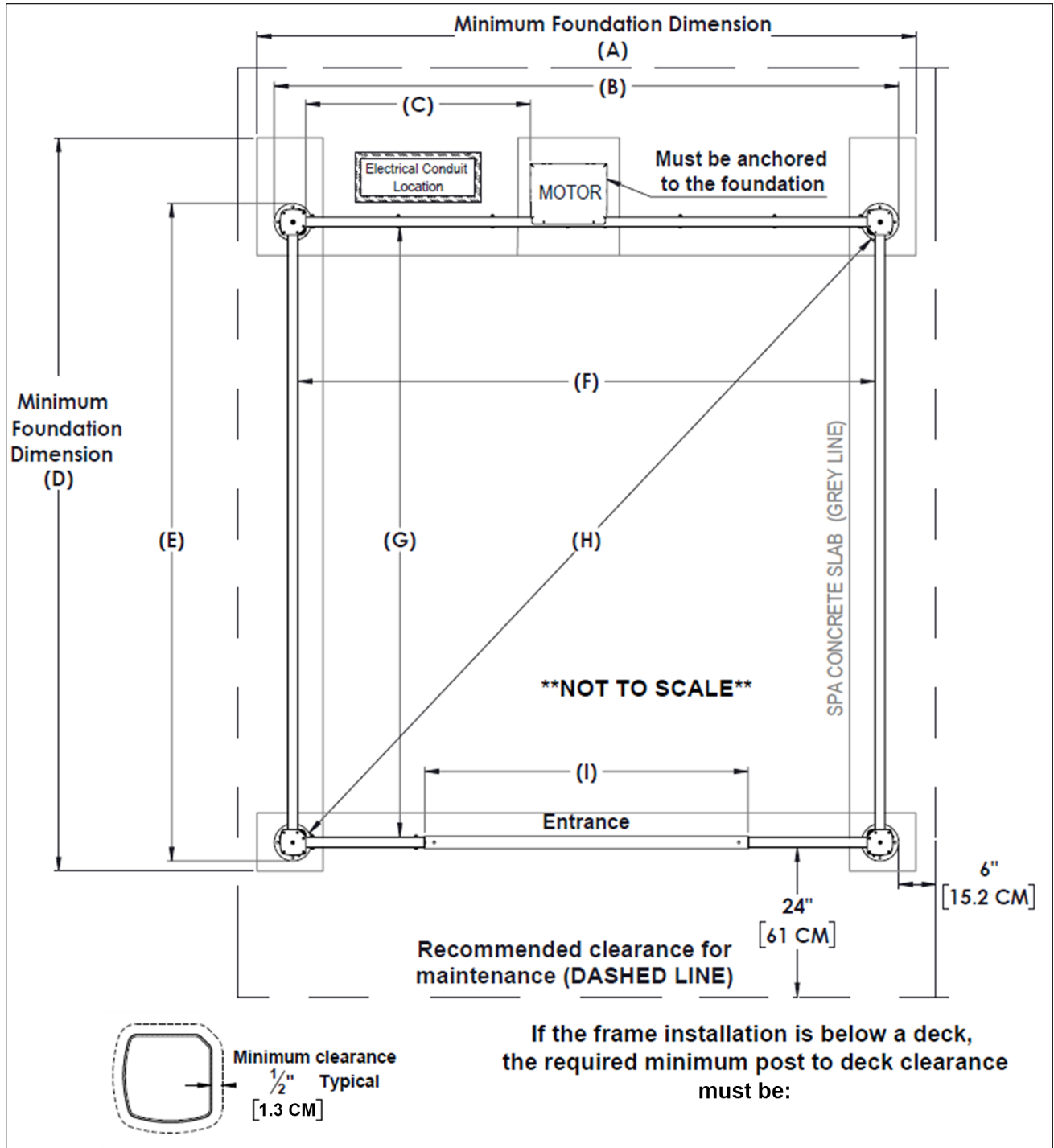

INCH (mm)	A	B	C	D	E	F	G	H	I
STANDARD MODEL	106 (2692)	100.5 (2553)	35 (889)	118 (2297)	105.75 (2685)	92.75 (2356)	98 (2489)	130.75 (3321)	52 (1321)