

THE CEILING FAN  
**SHOPPE**<sup>®</sup>  
 EST. 2005

# THE TRISTAR

BY TROPOSAIR

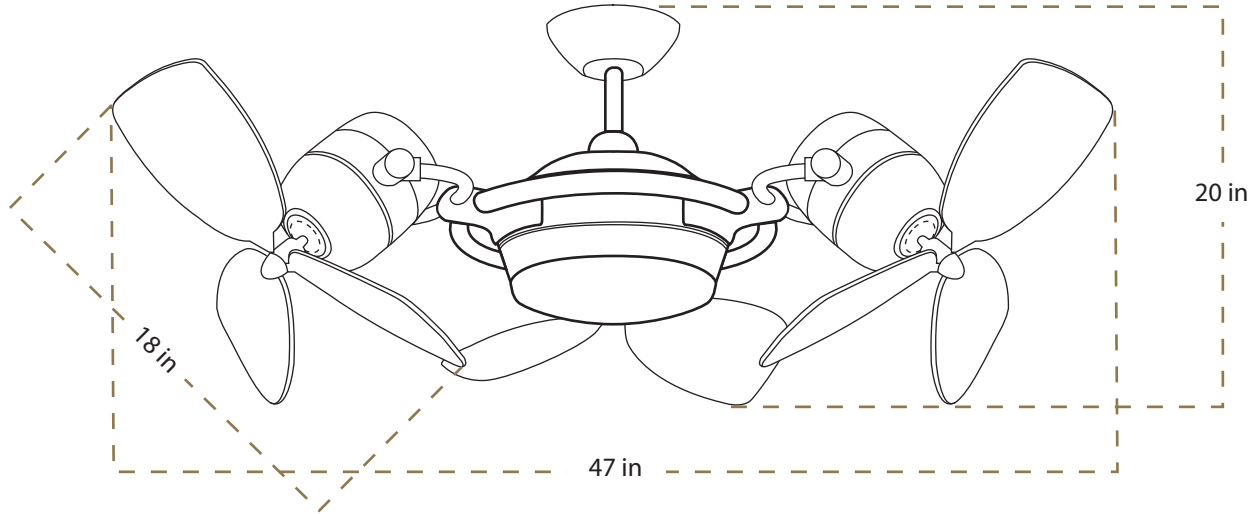

- FEATURES**
- 15-YEAR LIMITED INDOOR WARRANTY
  - 3-HIGH EFFICIENCY MOTORS WITH THREE BLADE DESIGN
  - PERMANENTLY LUBRICATED AND SEALED DUAL BEARINGS
  - UNIVERSAL HANGING SYSTEM FOR BEAUTY AND SAFETY. SPECIAL BALL HANGING MOUNT FOR VAULTED OR FLAT CEILINGS.
  - UNPARALLELED PLATING ON PLATED MOTOR FINISHES
  - THREE SPEEDS.
  - INTEGRATED LIGHT KIT INCLUDED
  - REMOTE CONTROL INCLUDED

**FINISHES**

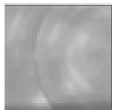

SATIN STEEL

| ENERGY INFORMATION<br>AT HIGH SPEED |                            |                                   |
|-------------------------------------|----------------------------|-----------------------------------|
| AIRFLOW                             | ELECTRICITY USE            | AIRFLOW EFFICIENCY                |
| 5218                                | 129.6                      | 40                                |
| CUBIC FEET PER<br>MINUTE            | WATTS<br>(EXCLUDES LIGHTS) | CUBIC FEET PER<br>MINUTE PER WATT |

\*DISCLAIMER: CEILING FAN MOTOR HAS BEEN TESTED WITH THE CORRESPONDENT SIZE BLADES.