

THE CEILING FAN
SHOPPE[®]

EST. 2005

60" ST. AUGUSTINE

BY TROPOSAIR

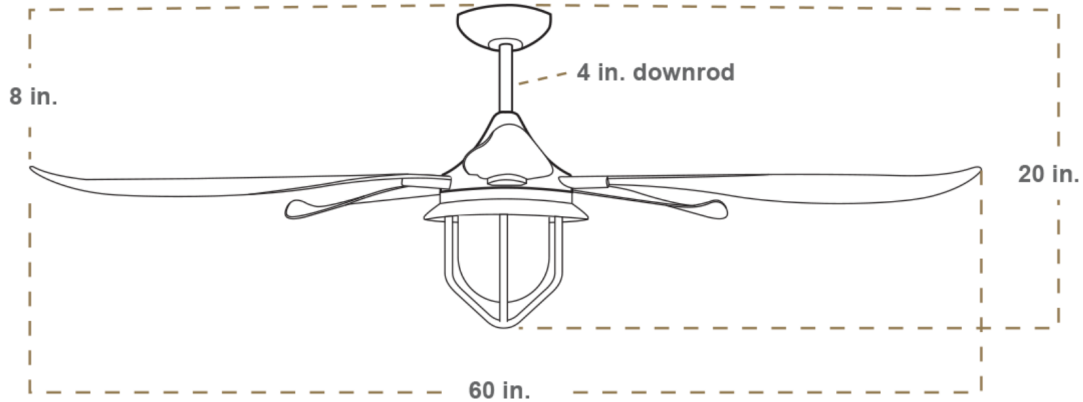

FEATURES

- INCLUDES 5 WEIGHT MATCHED CONTOURED ABS PLASTIC NON-WARP BLADES
- 6 SPEED HIGH PERFORMANCE DC MOTOR
- MAINTENANCE-FREE SEALED BEARINGS
- REVERSIBLE MOTOR FOR YEAR-ROUND EFFECTIVENESS (REVERSE VIA THE HANDHELD REMOTE)
- CEILING MOUNT FOR FLAT OR VAULTED CEILINGS UP TO APPROX. 8/12 PITCH
- INCLUDES 4" DOWNROD-EXTENSION.
- EXTENSIONS AVAILABLE SEPARATELY IN 12", 18", 24", 36", 48" 60" AND 72" IN THE MATCHING OIL RUBBED BRONZE COLOR
- EXTENSION ROD COUPLERS ARE AVAILABLE WHEN LONGER THAN 72" EXTENSION IS NEEDED.
- SUITABLE FOR RESIDENTIAL AND COMMERCIAL INSTALLATIONS.
- INTEGRATED LIGHT ASSEMBLY ACCEPTS ALL STANDARD BASED LIGHT BULBS WITH MAX WATTAGE RATING OF 60 WATTS
- LIFETIME TECH SUPPORT
- 5 YEAR LIMITED OUTDOOR WARRANTY
- LIFETIME LIMITED INDOOR WARRANTY

FINISHES

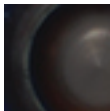

OIL RUBBED BRONZE

ENERGY INFORMATION AT HIGH SPEED

AIRFLOW	ELECTRICITY USE	AIRFLOW EFFICIENCY
7140	71.1	72.3
CUBIC FEET PER MINUTE	WATTS (EXCLUDES LIGHTS)	CUBIC FEET PER MINUTE PER WATT