

52" QUANTUM

BY TROPOSAIR

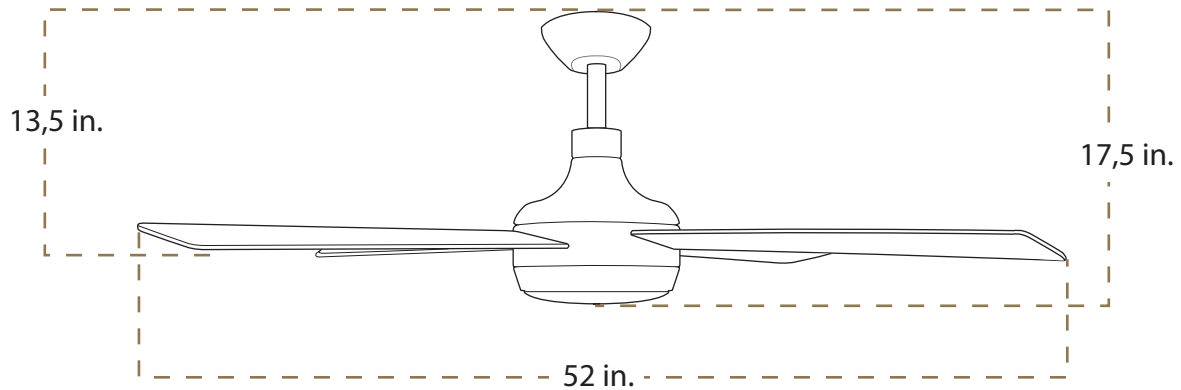

FEATURES

- LIFETIME INDOOR WARRANTY
- OPTIONAL INTEGRATED LIGHT
- FOUR REVERSIBLE MATCHING BLADES
- HIGH PERFORMANCE MOTOR
- PERMANENTLY LUBRICATED AND SEALED DUAL BEARINGS
- UNIVERSAL HANGING SYSTEM FOR BEAUTY AND SAFETY
- SPECIAL BALL HANGING MOUNT FOR VAULTED OR FLAT CEILINGS
- SPECIAL INTEGRATED BLADE IRONS WITH HIDDEN BLADE SCREWS
- ELECTRICALLY REVERSIBLE
- HAND HELD REMOTE CONTROL INCLUDED
- INTEGRATED LIGHT KIT AND COVER INCLUDED

AVAILABLE MOTOR FINISHES

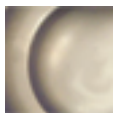

SATIN STEEL

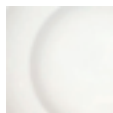

PURE WHITE

ENERGY INFORMATION AT HIGH SPEED

AIRFLOW	ELECTRICITY USE	AIRFLOW EFFICIENCY
5136	65.2	79
CUBIC FEET PER MINUTE	WATTS (EXCLUDES LIGHTS)	CUBIC FEET PER MINUTE PER WATT

*DISCLAIMER: CEILING FAN MOTOR HAS BEEN TESTED WITH THE CORRESPONDENT SIZE BLADES.