

DOUBLE WALL SHELF

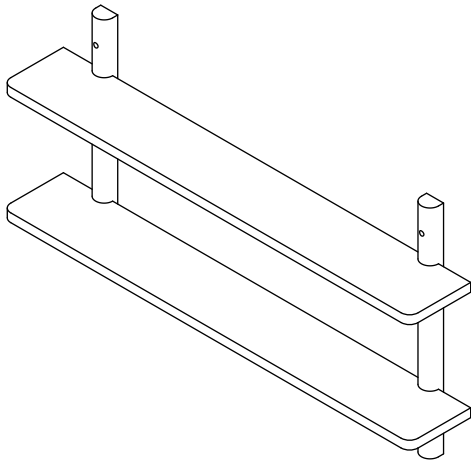

**KROFT**

# 30" SHELF

10 LB  
CAPACITY  
PER SHELF

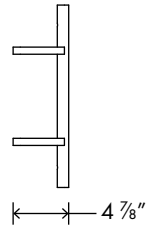
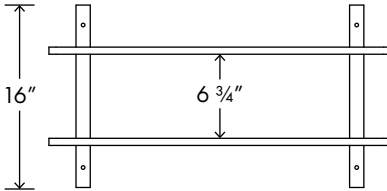
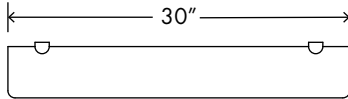

# 45" SHELF

15 LB  
CAPACITY  
PER SHELF

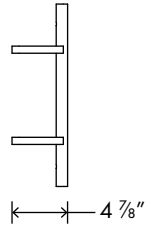
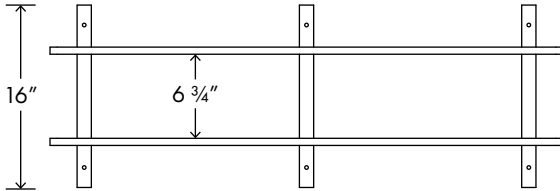
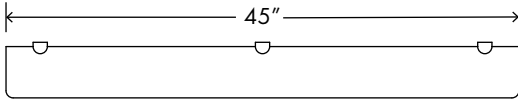

INCLUDED HARDWARE:

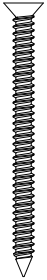

#10 Screw  
x 4



Drywall Anchor  
x 4



#8 Screw  
x 4



Screw Cap  
x 4

RECOMMENDED TOOLS:

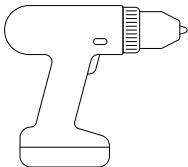

Drill

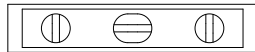

Level

1. Align shelf with centre holes on rails.

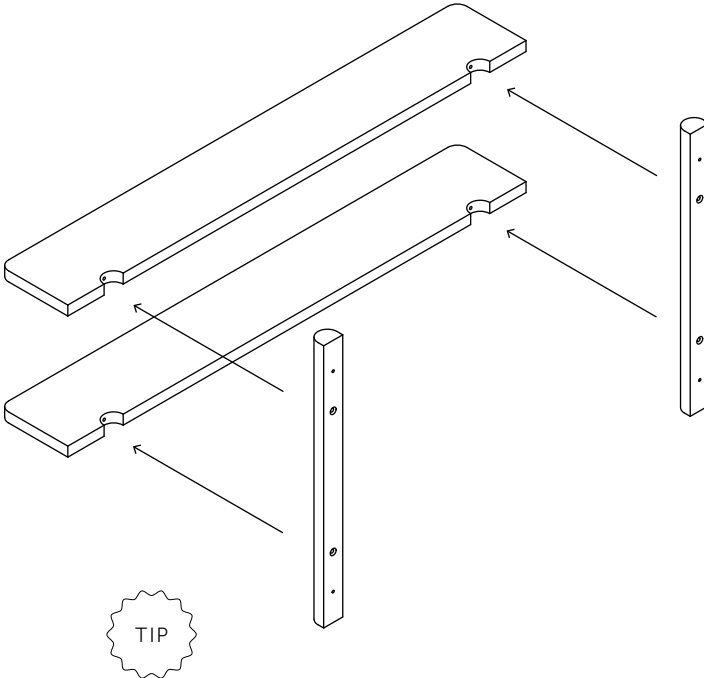

For ease of installation, we recommend having two people install the Double Wall Shelf.

2. Insert #10 x 2-½" screws through back of rails and into shelf.  
Using a power drill and a Phillips bit (an impact driver is ideal), fasten screws into place to secure rails to shelves.

To avoid heating screw, drive screw in about  $\frac{3}{4}$  of the way through the rails and shelves on first attempt and back out before fully fastening.

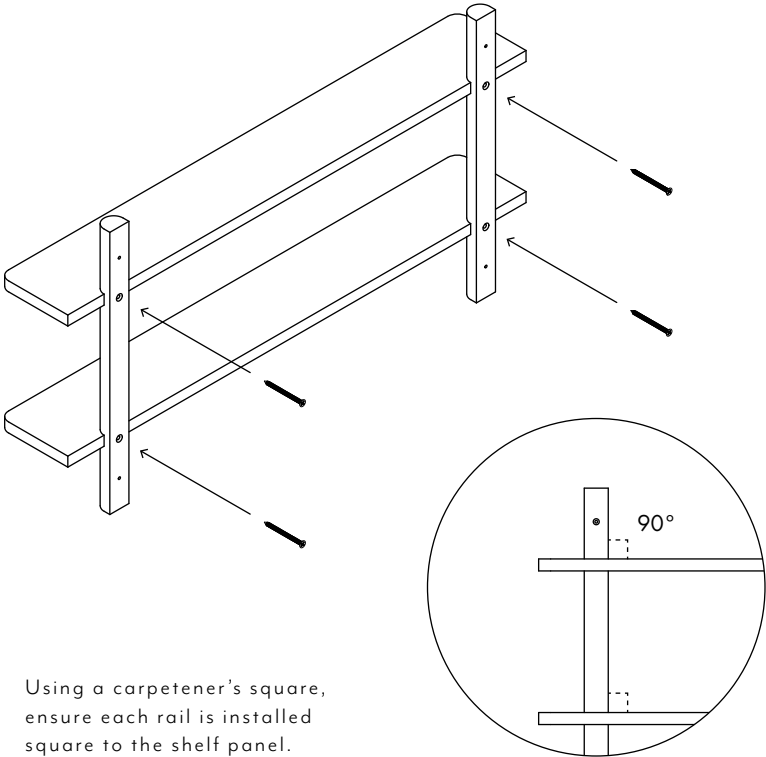

Using a carpenter's square, ensure each rail is installed square to the shelf panel.



For assembling Double Wall Shelf 45, begin by attaching the middle rail to the shelf panels first. Ensure the middle rail is square to the shelf panels before attaching the remaining two rails.

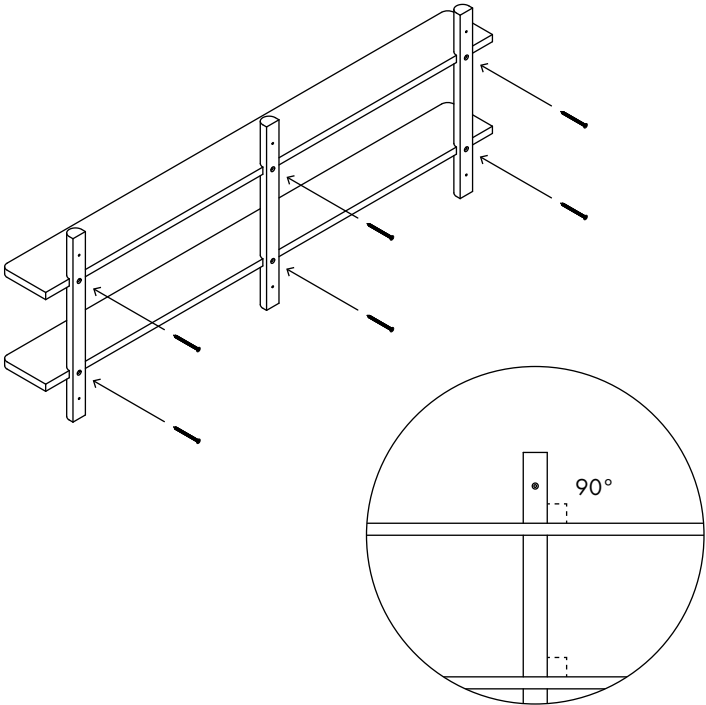

3. Paired with a level, place assembled shelf against the wall at desired height. Using screw provided, make a marking through each open hole onto the wall.

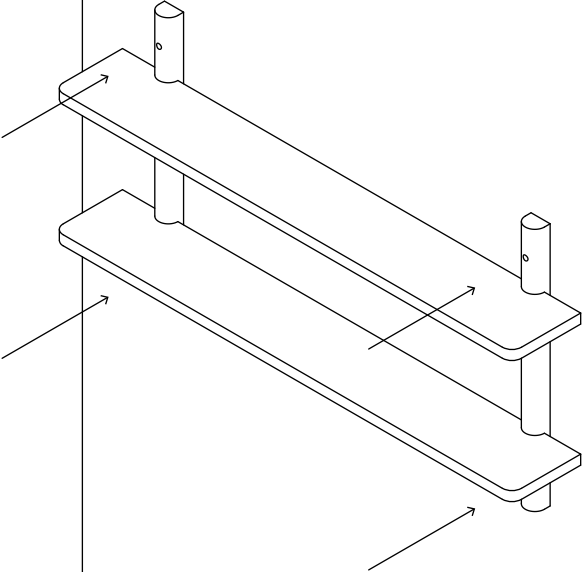



4. For drywall installation, use a 1/4" drill bit to create four holes through wall at marked points.



When drilling the hole, be sure to keep the drill bit level. This will ensure the rail is mounted flush to the wall.

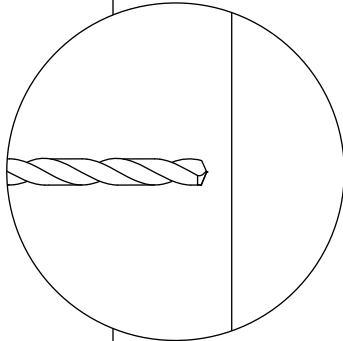
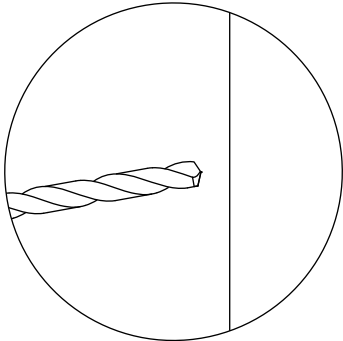

5. Insert drywall anchors into the drilled holes.

A hammer may be used to gently tap the anchor until it is flush with the wall, taking care not to drive the collar of the anchor beneath the surface of the wall.

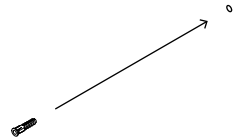
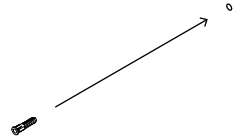
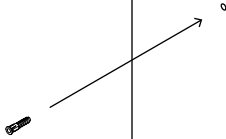
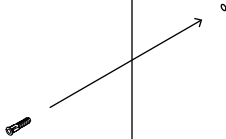

6. Insert #8 x 1-1/2" screws through the shelf rails and into the drywall anchors. Using a screwdriver or drill, drive screws into place to secure shelf to the wall.

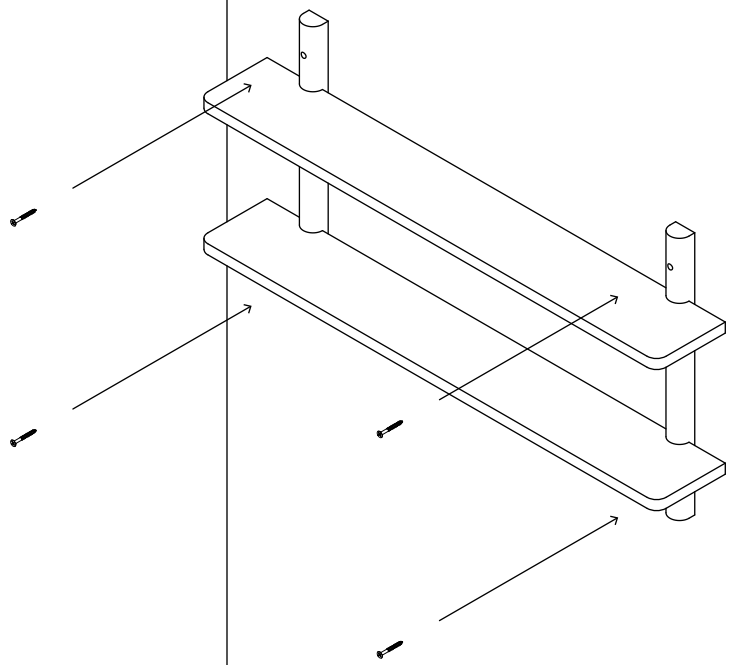

7. Insert screw caps into holes in rails to conceal the hardware beneath.

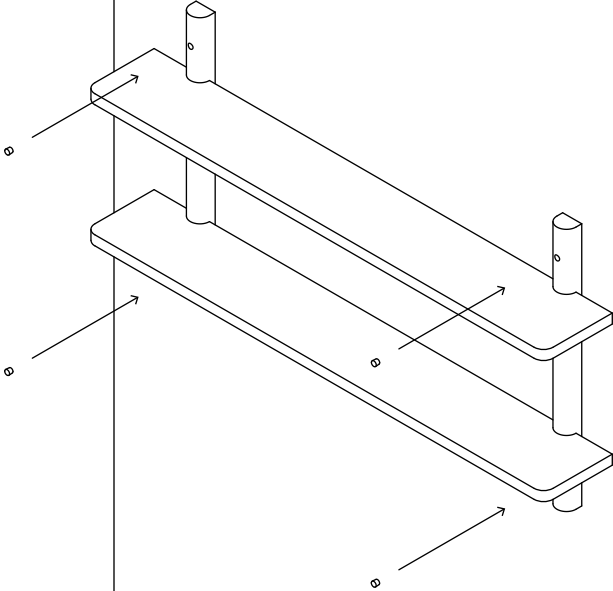

Done!

