

LEATHER STRAP SHELF

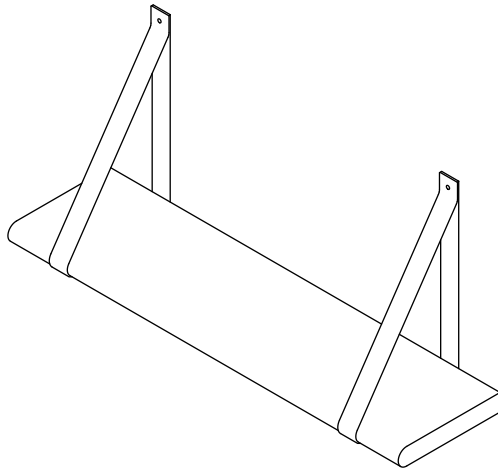

KROFT

23" SHELF

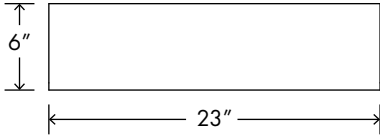
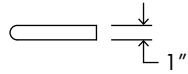

35" SHELF

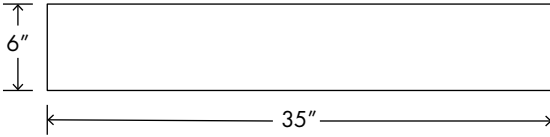
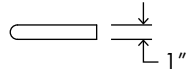

INCLUDED HARDWARE:



Washer
x 2

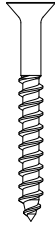

Screw
x 2

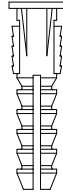

Drywall Anchor
x 2

RECOMMENDED TOOLS:

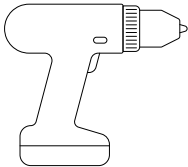

Drill

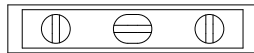

Level

HOLE DISTANCE RECOMMENDATIONS

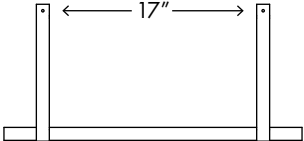

23" Shelf

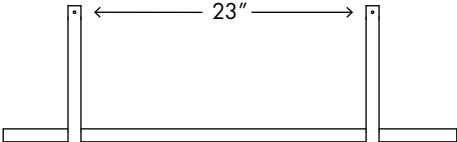

35" Shelf

1. Using a level, measure and mark two points on wall approximately 10" above desired height of shelf.

We recommend the following spacing for each shelf:

17" apart for 23" shelf

23" apart for 35" shelf

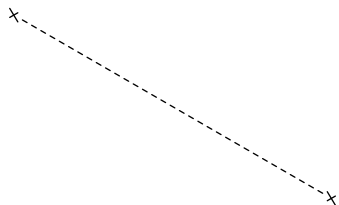

2. Using a 1/4" drill bit, drill two holes through wall at marked points.



TIP

When drilling the hole, be sure to keep the drill bit level. This will ensure the straps are mounted flush to the wall.

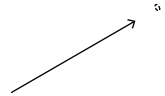
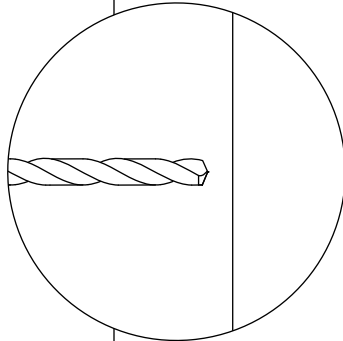
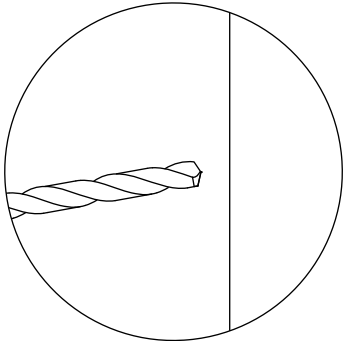

3. Insert drywall anchors into the drilled holes.

A hammer may be used to gently tap the anchor until it is flush with the wall, taking care not to drive the collar of the anchor beneath the surface of the wall

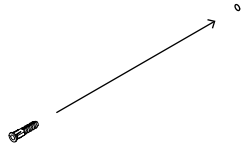
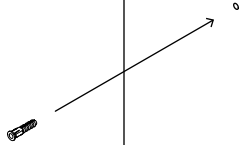

4. Fold leather strap in half aligning the two holes. Using a screwdriver or drill, secure to wall by inserting the screw over the washer then through the leather strap holes. Repeat with second leather strap.

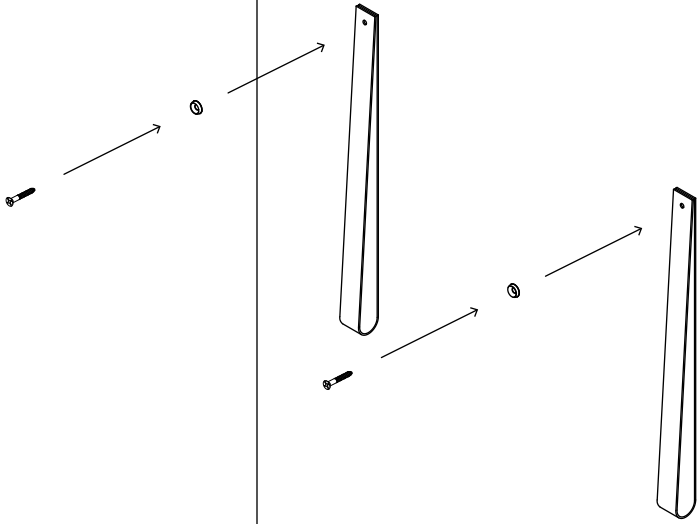

5. Insert shelf between the leather straps and adjust to level.

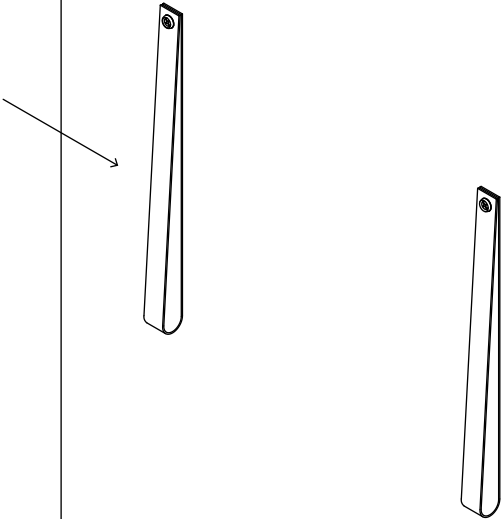

Done!

