

HANGING CLOTHES RACK

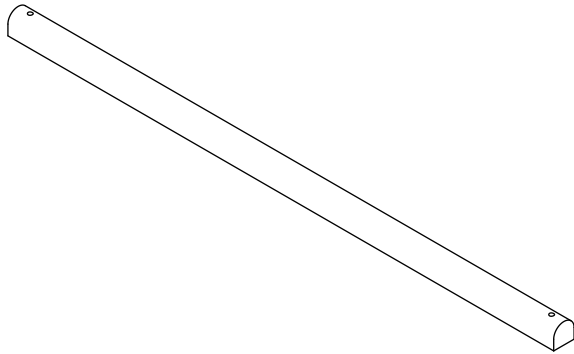

**KROFT**

HOLDS  
UP TO  
40LBS

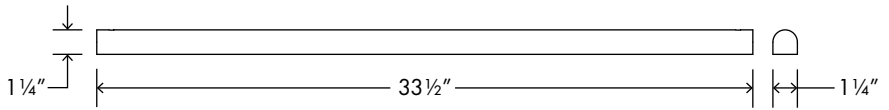
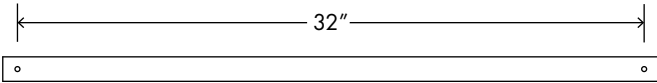

INCLUDED HARDWARE:

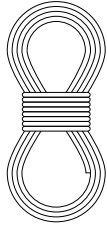

Cord  
16 ft



Screw  
x 2

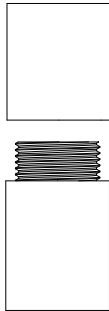

Stand Offs  
x2



Cord Grip  
x 2

RECOMMENDED TOOLS:

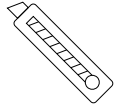

Utility Knife



Lighter

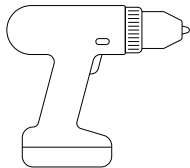

Drill

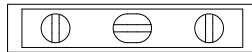

Level

For a video tutorial on how to install our hanging clothes rack, visit our product page or scan the code below.



The following are additional tips and tricks for an effortless installation.

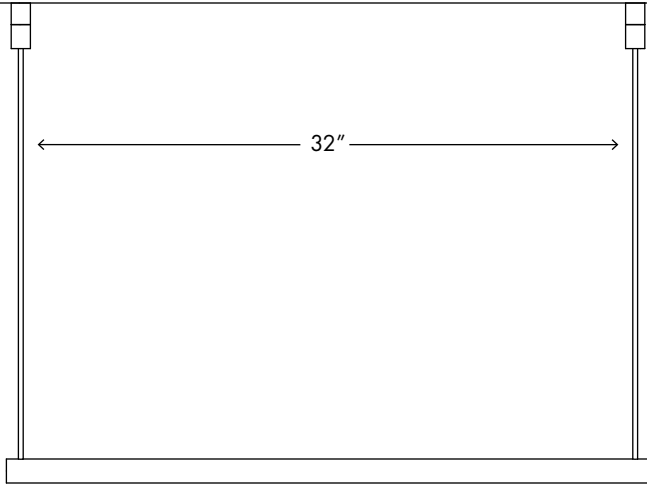

The hanging clothes rack is designed to align with ceiling studs for a secure installation. Holes must be drilled at precisely 32" apart and installed into studs behind drywall. They may also be installed directly into wood or concrete.

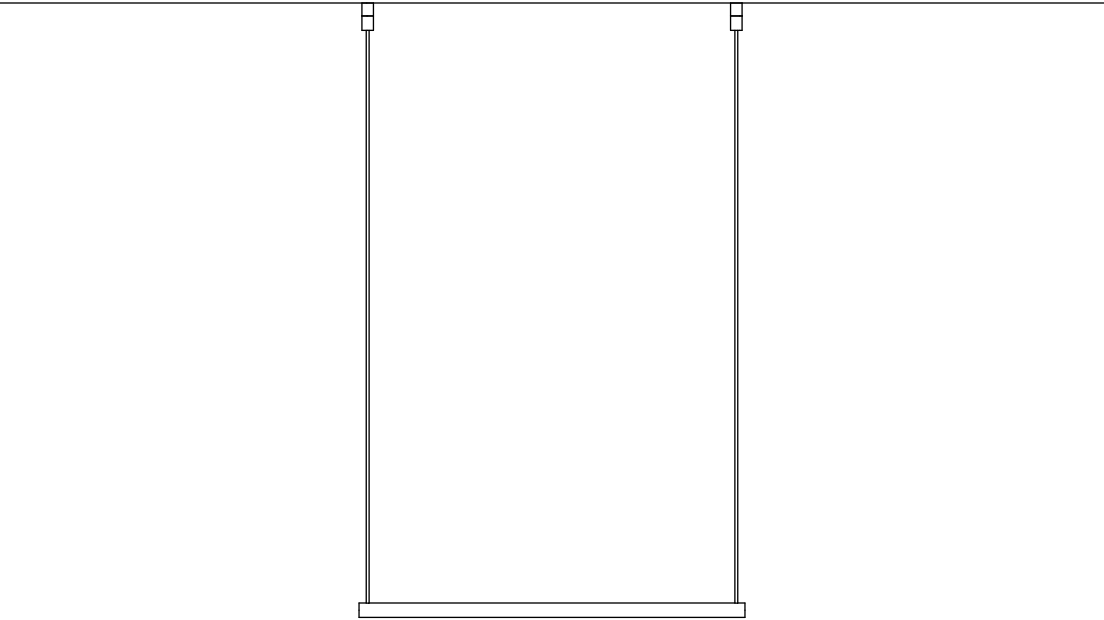

Install hanging clothes rack at full length first. The rack will hang approximately 6½ feet from the ceiling. The cord can be trimmed to adjust hanging height once installed.

Trim cord with a sharp knife for a clean cut.

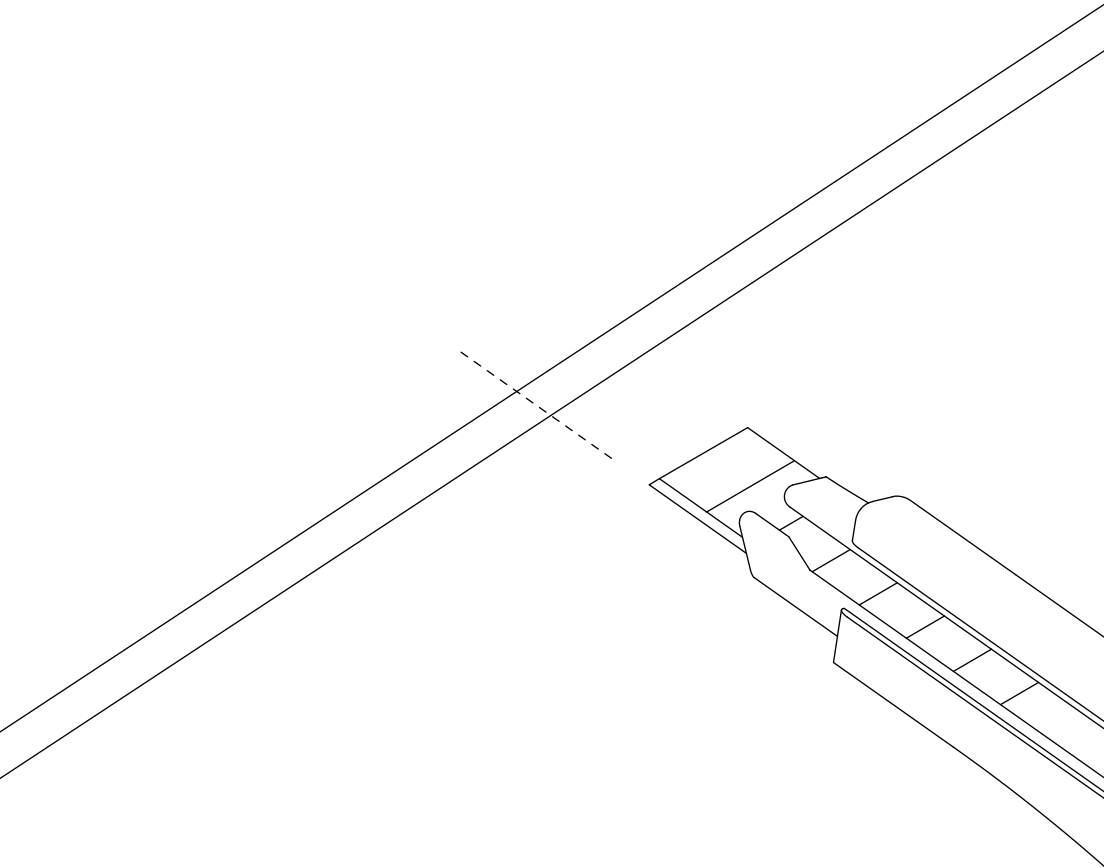



After trimming cord, apply lighter to end taking care not to burn the sides. Let cool before threading through cord grips.

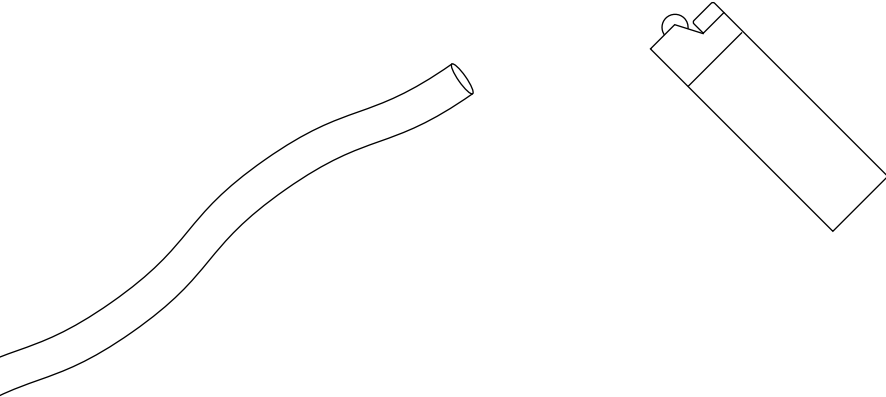

Be sure to leave at least  $\frac{1}{4}$ " excess of cord through the cord grip.

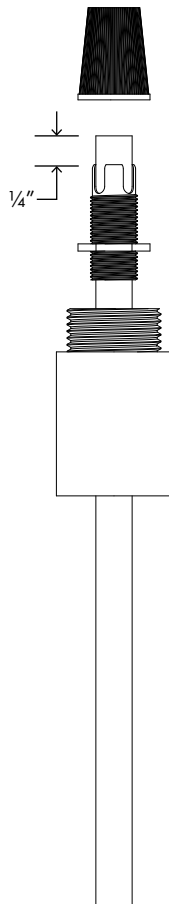

Ensure cord grip is tightened securely.

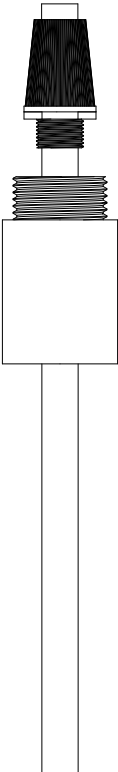

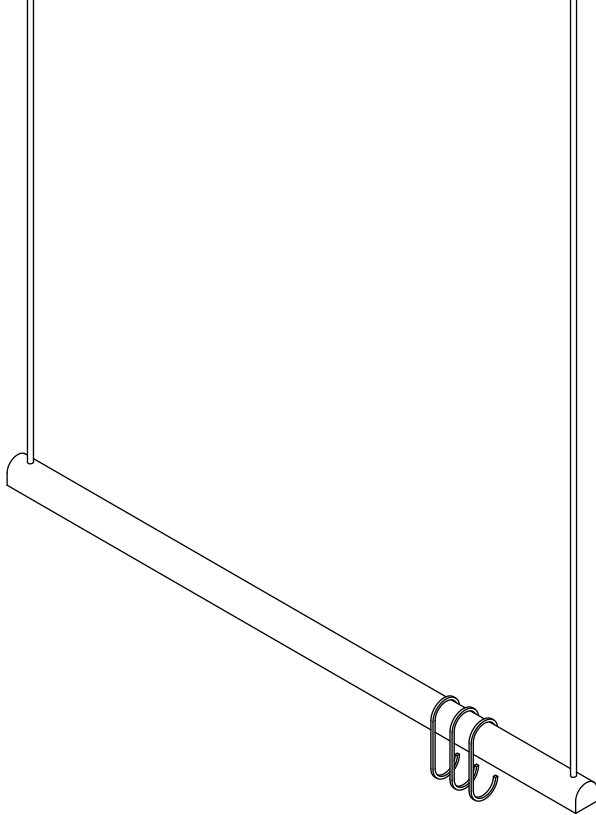

Pair with our C Hooks to make the most of the Hanging Clothes Rack