

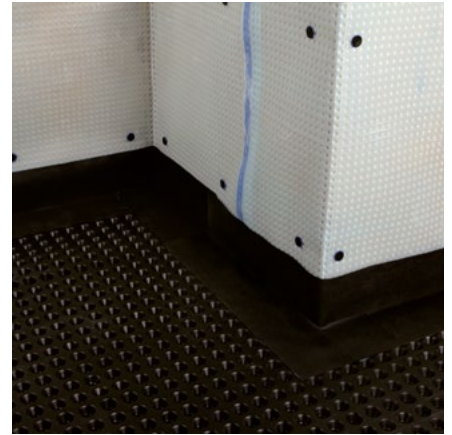

Platon Cavity Drain Membrane

INSTALLATION MANUAL



www.tritonsystems.co.uk

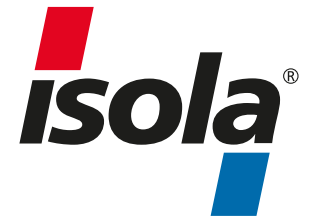

Contents

	Page
Isola and Triton – history and background	5
System Platon – an introduction	5
1. General Guidance Notes on Specification and Installation	6
2. Membrane Installation (internal basement application – P5, P8, P20)	9
3. Membrane Installation (internal basement application – Plasterbase)	14
4. Membrane Installation (external basement application Double Drain)	16
5. Triton Sump and Pump Installation	17
6. Installation Guidelines	18
7. Technical Specifications	18
8. Dimensions	26
9. Parts List	26
10. Accessories	26
11. Wiring Diagrams	27
12. Transport	27
13. Maintenance	27
14. Health & Safety	27
15. Triton Aqua Channel	27
16. Photographic Illustrations	32
17. Sumps & Pumps Guidance Notes	43
18. Pump Service Schedule	49
19. Pre and Post Installation Checklist	51
20. Pipe Service Seal Detail	53
21. Product Specifications	55

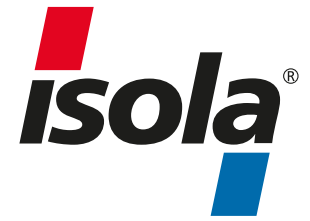

Isola Platon Membrane

Triton Systems

Background/History

Isola is the original inventor of studded membrane and was founded in 1940. The Isola Group has since grown to become one of the world leaders in the field of waterproofing membranes for the construction industry. Isola has also produced many millions of square metres of membrane products worldwide and through their research and development, continues to be at the cutting edge of innovation and technology in this field.

Triton Systems has been historically linked with Isola Platon since 1995 and in 1998 took over the U.K and Ireland operations to become the sole distributor and promoter of Isola Platon membranes and components.

Platon membranes, together with Triton's own extensive range of water proofing and damp proofing products and water drainage systems give the specifier and installation contractor the complete basement and above ground waterproofing system that is unique within our construction industry.

Isola Platon Cavity Drain Membranes

Platon Cavity Drain membranes "System Platon" are made of high-density studded polyethylene sheets (HDPE) and Polypropylene (PP), which are impervious to water and are vapour proof. When placed against structures the studs form permanent cavities between the structure and the internal shell. They can be used internally or externally to drain and control water and damp ingress.

"System Platon" is not a tanking system. The term "tanking" originates from the industrial process of lining structures with a waterproof material, which were applied either externally (on the positive side) or internally (on the negative side). Tanking materials such as multi-coat renders, cementitious waterproofing slurries, asphalts and liquid applied bitumen coatings, rely on either a mechanical or chemical bond directly on to the substrate and work by holding water back. The majority of these are vapour permeable.

Walls in the majority of circumstances are not engineered to withstand the bending stresses applied when a negative pressure barrier tanking system is used to hold back water pressure. Brick is very strong in compression but weak in tension.

Traditionally in the United Kingdom cementitious tanking systems are applied to below ground structures, but if the structure is subjected to hydrostatic water pressure, the resulting bending stresses are often far too great for the barrier system to cope with and therefore de-bonding or cracking, resulting in failure, will occur. The installation of Platon membrane doesn't change the status quo and therefore Platon Cavity membranes are ideally the most suitable and economical method of providing an effective and long lasting waterproofing system that is also sympathetic towards building structures. For those seeking maximum assurance 'System Platon' is considered to be the most trouble free.

1.0 GENERAL GUIDANCE NOTES

Properties and structures vary in design and form of construction. Any specification is therefore unique to individual properties and to any special or particular circumstances encountered that may relate to the structure. The guidance notes set out below have been put together as a 'guide only' in order to help the specifier and membrane installer. Therefore the information given in this text and that which is provided in any product data sheet issued by Triton Systems, is made without prior guarantee, as conditions of use and labour involved are beyond our control.

1.1 Site Survey and Design Consideration

1.11 Membrane Suitability

Platon cavity membrane can be applied to almost all sound building structures below ground, which are affected by dampness or water ingress. However, they are not recommended for installation in the following situations.

- Where the cavity membrane system cannot be drained, otherwise the system will fail. (See drainage facilities and guidance notes)
- Fixed onto internal flat soffits unless the soffit has an existing fall or a fall can be formed at the design stage (in the case of new build construction) or created using sand & cement renders, otherwise water would pond behind the membrane and build up like a balloon. The weight of water would inevitably burst the membrane seals, which are not designed to hold water under pressure. An alternative for flat soffits is shown in drawing no. IPO24.1.
- Under or on top of concrete/stone staircase treads and risers, because of the many convoluting junctions and angle details. In such circumstances, we recommend they be treated independently using an epoxy vapour barrier.

1.12 Ingressing Water

Platon cavity membranes are capable of dealing with (quite) large volumes of water, so ingressing water will not usually require remedial action. But if the flow rate is such that it will be able to carry silts/dissolved lime with it, then this inflow should be stemmed/controlled prior to fitting the membrane. This can be achieved as follows.

- If ingressing water is localised then the application of Triton Quick Set plugging compound (TQS) will often be sufficient. (See TQS data sheet)
- If ingressing water is more general and cannot be dealt with by localised plugging, consideration should be given to applying a general coat of 3:1 render incorporating an accelerator in the mix.

When water is flowing through concrete or mortar (particularly when it is new) there is a tendency for dissolved lime to be brought into the cavity. This lime can then come out of solution and block up cavities and drains. If this is a risk, then the source of water ingress needs to be treated in the same way as silt bearing water, as described above.

NB: Regardless of conditions at the time of inspection, BS 8102 says it must be assumed hydrostatic pressure is going to occur at some time during the lifetime of the basement. This means that some form of water removal system must always be fitted with the Platon cavity membrane in below ground structures.

1.2 Drainage Types

There are two principle forms of drainage, these are natural (gravity) and mechanical (sump & pump) and can be used in conjunction with falls or drainage channels. However, when assessing the type of drainage facility to be used and because the drainage is the key to the success of the cavity membrane system, it is important to take into consideration the following points.

1.21 Natural – (combined foul chambers & integral gullies)

Where drainage with gravity is feasible within the bounds of the property or at a point of exit from the property, it is most important to establish that the 'internal drainage' is in good working order and to question whether the local drains are connected to public drains or a soakaway. Drains can and do block up or back up causing flooding, including escape of foul waste and pungent smells. Soakaways can also fill up during periods of heavy rain, which would lead to

flooding and failure of the cavity membrane system. In situations where the Platon membrane installer finds that the only possibility of draining the cavity membrane is into a foul/soakaway system or his client so instructs, liability for the waterproofing system should therefore be excluded in the event of blockage of the foul pipes or the soakaways filling up. Isola and Triton always recommend the inclusion of sump and pumps.

1.22 Mechanical – (sump & pump)

Triton Systems produces an off-the-shelf sump and pump drainage system, 'The Aqua Pump Range' and 'Aqua Pump Pro Range' which has been specifically designed for the purpose of controlling ground water ingress. The simple to fit sump pump kit comprises a polyethylene pre-formed sump chamber with a structural lid. The submersible Aqua Pump is controlled by an automatic integral float switch and comes with a non-return valve and a high level water alarm that warns of mechanical or power failure. However, it would be prudent to install a double pump system 'The Aqua Pump Plus Kit' which consists of two pumps in the sump chamber. This secondary pump would provide a back up in case of mechanical failure of the principal pump. Consideration should also be given to installing a battery back-up pump in case of a power failure and is also available from Triton. (See technical data sheet).

1.23 Drainage Channel – (Triton Pre-formed peripheral conduit)

Triton also produces Aqua Channel, which is a P.V.C drainage conduit specifically designed for the control of water ingress in below ground situations. It is fitted around the perimeter of the floor at the vulnerable wall/floor junction and can be used in most waterproofing situations, and is particularly suited for use in conjunction with Isola Platon Cavity Drain Membrane systems. Water entering the building through the walls is controlled behind the Platon Membrane and diverted to the Aqua Channel at the base of the wall. The water enters the Aqua Channel through pre-drilled drainage holes and must then be diverted to a suitable drainage point, either natural or a sump and mechanical pump. Jetting eyes (cleaning ports) can also be incorporated into the Aqua Channel.

1.24 Falls – (Floors)

It is essential that there are no undulating surfaces or depressions in the floor. In new build or whenever floors are being replaced, the floor slabs can be designed and constructed to falls 2° or 3° towards the water collection facility i.e. sump chamber. Where an existing solid floor is to be retained a sand/cement screed can be laid over the entire floor gently sloping towards the sump. In all cases the floor should always be tested by spraying with a hose, to ensure that all water finds its way to the water collection point before laying the cavity membrane.

NOTE: Wherever possible (head height permitting) we recommend that Platon P20 be used on floors. This is because the P20 membrane has a far greater drainage capacity and significantly reduces the risk of hydrostatic pressure building up within the cavity.

1.3 Undermining Structures

1.31 Sump Chambers

Consideration must be given to the implications of fitting sumps in the ground, e.g. where unstable elements are present, such as chalk or sand. The installation of a perforated sump chamber could cause washing away and potential undermining. Therefore, in such cases, only sealed sumps should be installed and structurally held in place by concrete etc, with the water collection limited to that entering from the drainage channels. The final decision on the sump type in cases where ground conditions are unknown should be delayed until excavation is undertaken.

IMPORTANT NOTE: If there is any concern as to whether there is a risk of de-watering the ground to a condition whereby the structure as a whole could or may be undermined, then advice should be sought from a chartered engineer.

(see also sump installation guidance notes in the appendix).

1.32 Drainage Channel

If the Triton Aqua Channel cannot be formed/inserted into the floor at the wall/floor junction, because there are in-situ reinforcing bars in the slab. Then either a fall must be created in the floor (as previously described under the heading falls) or a series of small surface channels (cut into the floor like chevrons) must be formed with a fall towards the direction of the sump/water collection chamber.

1.33 Existing Plasters

Plaster that may be affected by being closed in behind the Platon cavity membrane, such as gypsum or lightweight plaster, or where the existing plaster is loose or de-bonding, should be removed from walls/soffits prior to membrane application. Only where dense and well adhered sand and cement renders are present and where removal may cause unwanted structural damage to substrates can they be left in place.

1.4 Substrate Preparation

One of the benefits of using cavity drain membrane is that in general, very little preparation to the substrates is required and although the cavity membrane is flexible and does not need a perfect surface for application, the following points need to be considered.

- Unsound materials on the surface like renders or plasters need to be removed. (See also Existing Plasters above.) Any organic materials such as wallpaper, timber skirtings, fixing grounds etc need to be removed.
- A specialist timber treatment contractor should investigate any fungal decay/infestations in timbers. Also timber that is in contact with damp masonry should be removed or physically isolated.
- Excessively uneven wall and floor surfaces should be dubbed out/levelled especially if timber battens are to be fixed to support dry lining board. Where a wooden floor finish is required such as T&G flooring grade chipboard, it must also be borne in mind that the membrane will follow the contours of the floor. Therefore to achieve a flat surface, any depressions or undulations must be ironed out to avoid undue movement in the floor finishes.
- Substrates must be free of sharp protruding objects and debris etc that can damage the membrane. We would also recommend that where mould, mosses, lichens and algae has affected substrates, a surface sterilisation with Triton Trisol 23 should be used.
- Loose, friable or defective masonry should be repaired to ensure a solid fixing.

See additional notes on preparation and installation checks further on in this manual.

2.0 MEMBRANE INSTALLATION – (internal applications in below ground structures)

2.1 Internal Basement Structures

Set out below is a generic method of installation, which can be used to apply Platon P5, P8 or P20 cavity drain membranes continuously between wall and floor. NB it is assumed by this stage, that the site and design considerations mentioned earlier in this document, have been assessed and the type of drainage facility chosen has been tested. The installation of Platon Plasterbase and Double Drain are covered under a separate heading further in this document.

2.2 Walls and Floors

2.21 Wall application using Platon P5, P8 or P20

The installation of Platon P5, P8 or P20 membranes can be fixed to walls either vertically or horizontally, but when choosing the method of application, consideration should be given to the height of walls in relation to the size of the roll of membrane. There are fewer joints in horizontal applications but it can be awkward and difficult to manoeuvre the weight of a full roll of membrane. Particularly in situations where the membrane has to be taken in and out of numerous recesses, also around convoluting junctions or where walls are not square. Vertical application may have more joints, but this method is more manageable and much easier to fix.

Platon P5 and P8 membranes are fixed to walls with the Platon Brick Plug. The brick plugs should be prepared for use before fixing by wrapping Platon Sealing Rope around the neck of plug just under the head. This will form a seal with the membrane when the plug is driven home into the substrate. (See fig 1)

If the ceiling height is constant, measure and cut drops of the membrane to completely cover the wall areas to be treated. Place the membrane against the wall as level as possible by eye sight and in the top right or left hand corner (depending on which way around the room the membrane is being taken) drill a hole through the centre of the membrane stud using a 10mm drill bit. Insert the brick plug and hammer home the plug till it finishes flush with the membrane. (See fig 2)

Using a spirit level, level out the membrane and then drill and fix another brick plug in the same manner approximately 1.5m along the top of the sheet and along the same line of stud as the first fixing. Offer up the next length of membrane and position the flange over the studs of the first sheet and fix with two Brick Plugs at high level as previously described. Continue on in this manner, ensuring the membrane stays as level as possible until all the walls are covered. These independent membrane drops will relax after a while and hang flatter to the wall. The drops are now ready for the next step.

Thoroughly clean the flange and the studs where the seal is to be made, (the best cleaning material is a standard kitchen roll). Any dust or dirt will compromise the integrity of the sealed joint. If the membrane is covered in plaster or brick dust, wash off with clean fresh water only and allow to dry. DO NOT use soap or detergents, as these will leave traces on the membrane, which may affect the seal at a later date or make sealing more difficult.

The separate membrane drops should now be sealed together using Platon Sealing Tape. Apply the tape to the stud area below, which the flange will cover and press home onto the area between the studs. Flick over the flange section to cover the tape line, and check for uniformity of cover on tape line. Remove the tape backing paper, starting from the middle section of the wall drop, forming two backing paper tags, one going up and the other down. On the exposed section of tape apply hand pressure only to the flange to form an initial seal. Carry on to form the seal from the centre section of membrane working up to the top, then go back to the centre and repeat the operation going downwards. Sealing in this manner will prevent any buckling between the membrane or stress concentration at the joint. In very cold or humid conditions a hot air gun can be used to obtain a good sealed joint. (See fig 3, 4, 5, 6)

Now that the membrane is sealed to form one continuous sheet, Platon Brick Plugs can now be fixed through the membrane in position to accommodate the chosen dry lining system.

NOTE: Although a 10mm drill bit is the correct size to use, in very soft brickwork this can result in loose

fixing. In these circumstances, it is useful to have on hand drill sizes down to 8mm and experiment with different sizes for the best results.

2.22 Floor application using Platon P20

Once the membrane has been fitted to the walls and before the dry lining system is installed, the floor membrane needs to be laid. As mentioned earlier in this document Platon P20 membrane is recommended on floors unless there is a head height restriction, in which case Platon P5 or P8 can be used, but the installation of Platon P5 or P8 on floors differs slightly from that of P20 and is explained below.

Begin at one side of the room and unroll the Platon P20 floor membrane against the wall membrane with the studs facing down onto the floor and cut the membrane to the desired length or width of the floor, just like laying a carpet. Repeat this exercise till all the lengths/widths required to cover the floor area have been cut allowing for a two-stud membrane overlap. (See fig 7)

The individual sheets of membrane that have now been cut, are joined together with Platon Sealing Rope. The sealing rope is positioned between the two stud formations along the edge of the membrane to be overlapped and remove the release paper. Lift the next sheet of P20 membrane over the two interlocking studs and press the overlapping membrane down onto the sealing rope. (See fig 7, 8, 9, 10)

Foot pressure can be applied by sliding the sole of the foot over the membrane joint, to ensure that the membranes are fully bonded. The next stage of the operation is to link the P20 floor membrane to the wall membrane, which can be achieved, using Platon Wall/Floor Junction or Corner Strip. Using Platon Wall/Floor Junction, work out how many linear metres there are around the walls, the Platon Wall/Floor junction is produced in manageable 2LM lengths with a crease formed in the centre. Fold the material in half down the centre crease and then apply Platon Sealing Tape along the edges of the wall/floor junction material and leave the backing paper on. (See fig 11)

If the one-sided adhesive corner strip is chosen to link the floor and wall membrane, the corner strip is folded in half along the length of the piece to be used and positioned with the crease into the angle as described for the wall/floor junction. Once correctly aligned, carefully pull off the backing paper and press firmly out with the palm of the hand onto the floor and wall membranes. Internal and external angles can be formed in the same manor as the Platon Wall/Floor Junction, but because it is a one-sided self-adhesive material and will stick to itself, no additional sealing tape is required. (See fig 12, 13, 14, 15, 16, 17)

2.23 Floor application using Platon P5 or P8

As with the P20, begin at one side of the room and unroll the floor membrane against the wall membrane with the studs facing down onto the floor. Allow for the membrane flange overlap, cut the membrane to the desired length or width of the floor. Repeat this exercise until all the lengths/widths required to cover the floor area have been cut.

Roll out the next length/sheet of membrane and position the flange over the studs of the first sheet laid and thoroughly clean the flange and the studs where the seal is to be made as previously described for wall application. Apply Platon Sealing Tape to the stud area below which the flange will cover and press home onto the area between the studs.

Flick over the flange section to cover the tape line, and check for uniformity of cover on tape line. Remove the tape backing paper, starting from the middle section of the membrane sheet, and peel off backing paper in opposite directions along the flange. On the exposed section of tape apply hand pressure only to the flange to form an initial seal. Carry on forming the seal working away from the centre of the membrane. Foot pressure can be applied by sliding the sole of the foot over the membrane joint, to ensure that the membranes are fully bonded. Sealing in this manner will prevent any buckling between the membrane or stress concentration at the joint. In very cold or humid conditions a hot air gun can be used to obtain a good sealed joint.

The next stage of the operation is to link the floor membrane to the wall membrane, which can be achieved, using Platon Wall/Floor Junction or Corner strip. Using Platon Wall/Floor Junction, work out how many linear metres there are around the walls, the Platon Wall/Floor Junction is produced in manageable 2Lm lengths with a crease formed in the centre. Fold the material in half down the centre crease and then apply Platon Sealing Tape along the edges of the wall/floor junction material and leave the backing paper on.

Ensure that the floor and wall membrane is clean and free from debris, dust and moisture and then position the Platon Wall/Floor Junction with the crease into the angle. Working from the centre, carefully peel back the backing paper in each

direction and use hand pressure along the taped edges to form a seal. To form internal and external angles using Platon Wall/Floor Junction, the wall/floor Junction is cut to the centre line and bent either inwards or outwards depending on the angle. The edges are then sealed with tape to the membrane in the same manner as described above.

If the one-sided adhesive corner strip is chosen to link the floor and wall membrane, the corner strip is folded in half along the length of the piece to be used and positioned with the crease into the angle as described for the wall/floor junction. Once correctly aligned, carefully pull off the backing paper and press firmly out with the palm of the hand onto the floor and wall membranes. Internal and external angles can be formed in the same manner as the Platon Wall/Floor Junction but because it is a one-sided self-adhesive material and will stick to itself, no additional sealing tape is required. (See fig 12, 13, 14, 15, 16, 17)

2.24 Flat Soffit Application using Platon P5 or P8

As previously mentioned earlier in this document, Platon cavity drain membrane should not be fixed to the under side of a flat soffit unless a fall exists or a fall can be created in the soffit itself. The soffit should first be measured to establish the desired lengths or widths of membrane required to cover the area and then a further 200mm of membrane should be added to the measurements, to allow for the membrane to be lapped down all the peripheral walls.

Apply sealing rope to the Platon Brick Plugs as previously described. Then around the perimeter edges of the membrane, fold the membrane inward 200mm to form a positive creased and create a down lap. Offer the membrane up to the soffit and position the down lap creases into the junction between the soffit and wall.

Drill and fix enough Platon Brick Plugs through the membrane and into the soffit to hold the membrane in place with the studs against the soffit. NB: Wherever the soffit membrane meets the wall, a 200mm down lap must be allowed and formed as above.

Offer the next length/sheet of membrane up to the soffit and position the flange over the studs of the first sheet, fix and secure the membrane as described above. Repeat this operation until all the membrane sheets are held in place. Thoroughly clean the flange and the studs where the seal is to be made as previously described for wall application. Apply Platon Sealing Tape to the stud area, which the flange will cover and press home onto the area between the studs. The membrane should now be sealed to form one continuous sheet, Platon Brick Plugs can now be fixed through the membrane, in positions to accommodate the chosen dry lining system.

NOTE: It is important to ensure that the membrane is taut against the soffit and doesn't sag, otherwise water ponding will occur and the membrane/seals could fail.

Internal and external corners are formed in exactly the same way as that which has been previously described in 'Floor application using Platon P5 or P8 with membrane upstand' except in this case, they will be formed in reverse and be upside down.

NOTE: An alternative method for dealing with flat soffits using a combination of Platon membrane to walls and Triton TT55 slurry to soffit can be seen in drawing IP025.1 on the technical drawing page at tritonsystems.co.uk

2.25 Service Entry Seals

Where there are services such as pipes, ducting or steel stanchion that protrude through walls or floors, the membrane should be carefully cut and trimmed around the obstacle and sealed using a combination of Platon Sealing Rope or flexible mastic and corner strip material. Cloaks can also be formed using the wall/floor junction. (See fig 18 and drawing IP027.1)

2.26 Doors and Windows

Door and window frames and timber surrounds should always be removed to enable Platon membrane to be extended around or into door and window reveals to maintain the continuity of the waterproofing system and to also provide a physical barrier between the frames and damp masonry. In situations where the Platon membrane would restrict or limit the profile of replaced frames, then Platon Wall/Floor Junction or Platon DPC Plain can be used to line and protect the reveals instead. See drawing no. IP026.1.

2.27 Ventilation – Part F of Building Regs

There is no requirement to ventilate the membrane cavity in a fully sealed system such as in under pavement vault application. In a semi sealed system, the cavity between membrane and substrate can be vented into the room space with passive vents or if this is not possible, it can be vented through the external wall using a 150 x 225 air brick inserted every 1.5m to 2.0m along the wall. It is important that the cavity between the membrane and internal finish i.e. dry lining is not vented so as to avoid possible interstitial condensation. However, consideration should be given to the risk of condensation forming within the room itself and the introduction of a humidistat controlled extract fan should therefore be recommended. Refer to BS8102 (2009) Table 2 for further reference. Part F of Building Regulations concerning ventilation in basements. Please refer to Triton's Anti Condensation Products brochure for suitable products such as Positive Pressure units.

2.28 Wall Finishing

If timber battens are to be used, the traditional method is to fix a vertical batten 25mm x 50mm. The brick plugs in this instance should be fixed at 400mm centres horizontally and 600mm centres vertically. The timber batten is screw fixed into to the self-tapping hole, which has been formed in the Platon brick plug using a size (10) x 2" screw. NB: We would however, recommend that foil back plasterboard be used to prevent interstitial condensation forming in the cavity.

For a metal fast track dry lining system such as Gypliner or Lafarge, the brick plugs should be fixed at 600mm centres horizontally and 800mm centres vertically. If an independent timber or metal frame system is to be used, the wall membrane can be 'curtain hung'. The membrane is simply dressed down the walls just like hanging a curtain or sheet. This method of installation requires less fixings.

NOTE: We would however, recommend that foil back plasterboard be used to prevent interstitial condensation forming in the cavity.

On fair faced walls the Platon Plaster Dab Collar System can be used. The collars, which incorporate a built in fixing plug going through the centre of the collar, are sealed as before with rope on the collar face rather than under the fixing plug head. The fixing collars are set out according to the width of the plasterboard to be used. (See fig 20, 21)

Generally, eight collars per sheet of plasterboard are required. The dab collars on the edge will also take the next sheet of plasterboard. When the collars have been fixed, insert 25mm size 10 screws into the pre-formed hole of the brick plug and adjust the screws in or out as the case may be to a constant final fix level for the final board finish.

Mix the plasterboard adhesive in accordance with manufacturer's instructions, and apply dabs of adhesive to the collars, ensuring that it goes through the collar gridding, and generously covers the levelling screw heads. Place some batten off cuts on the ground under the bottom of the plasterboard to support it until the adhesive has set. Stand the plasterboard on these support battens; position and press home onto the adhesive until the levelling screws stop any further movement.

The plasterboard must now be left for the adhesive to set, after which the support battens can be removed.

NB: Unfortunately, this form of dry lining system cannot be used with foil back plasterboard because the adhesive won't adhere to the foil back material.

If an independent brick/block wall needs to be built in front of the Platon wall membrane and requires lateral restraints, then Isola Bluebird Fixings can be used or a similar suitable product. Isola Bluebird Fixings are screwed into the self-tapping hole of the Platon Brick Plug and anchored into the mortar bed joint as the wall is built. (See fig 26) Independent free standing walls can also be built directly off Platon floor membranes, but we would recommend advice is sought from our technical department before proceeding.

2.29 Floor Finishes

There is a wide choice of floor coverings that can be laid on top of Platon floor membranes:

Platon P5 or P8 (Wood based flooring)	Flooring grade T & G chipboard, parquet, laminate, wood strip
Platon P5 or P8 (Sand/cement screeds)	Domestic: Minimum 50mm screed or 20mm reinforced polymer modified self-levelling screed. Industrial: Minimum 75mm reinforced screed or 35mm reinforced polymer modified self-levelling screed.
Platon P20 (Wood Based Flooring)	Flooring grade T & G chipboard, parquet, laminate and wood strip can also be applied, but a T & G chipboard base should be laid first.
Platon P20 (Sand/cement screeds)	Domestic: Minimum 75mm reinforced screed. Industrial: Minimum 100mm reinforced concrete.

2.30 Insulation

For Platon membrane applied to walls at or above ground level, the maximum insulation thickness should be 50mm. When Platon membrane is applied to earth retaining walls full height of a basement, there is no upper limit to insulation thickness. However, if Platon membrane is applied to part earth retaining walls, then the maximum insulation thickness should be 50mm. There is no upper limit to insulation thickness for Platon membrane applied to solid floors at ground or below ground level.

2.31 Curved Soffits and Vaulted Rooms

When working in a conventional vault with rounded ceilings the water can run off freely and the following method should be adopted:

When lining vaults always work from the front to the back, starting on the centre line of the vault. Measure the length of the vault and add 400mm to this measurement, then cut the membrane to the length. Form a 900 downturn crease 200mm in from either end of the membrane and prepare the Platon Brick Plugs by wrapping with Platon Sealing Rope as previously described.

Offer the membrane up to the vault ceiling along the centre line of the vault, and drill and hammer home the fixing plugs in a straight line at 600 centres from front to rear. These will provide fixing points for the dry lining system. The creased downturn at either end of the vault will start to deform going into the curvature of the vault ceiling. Where this occurs, carefully slit/cut the deformed sections towards the crease but stop short of the crease by one stud.

The membrane can now be overlaid and will flatten out and follow the curvature. Several slits may be required to achieve this depending on the radius of the vault. Continue to work out from the first sheet, ensuring a weathered joint of not less than eight studs. The flange should be used to make both of these weathered joints either side of the initial membrane fixed off the central line of the vault. The weathered joints are sealed flange over stud using Platon Sealing Tape in the manner previously described.

All the sheets running from front to back of the vault are cut overall length of vaulted soffit. This should give coverage to the vault, past the springing line down to the floor slab line, together with a 200mm return to either end of the vault.

The end walls are now ready to be lined with the membrane. The end wall sections are cut to the true width of the vault so that the membrane overlaps the membrane returns already formed. These sections of membrane are fixed and sealed in exactly the same way as described for wall application. The end wall membrane stud to stud joint should be sealed around the radius with Platon Sealing Rope and if necessary Corner Strip. The floor membrane is now ready to be laid over the completed drainage system. The wall/floor junction, corner strip or creased upstand is always in front of the wall membrane and sealed on the perimeter with Platon Sealing Tape or Rope.

3.0 PLATON PLASTER BASE MEMBRANE AND PLATON MESH APPLICATION – (internal applications in below ground structures)

Platon Plaster Base can be applied onto existing solid wall finishes. All surfaces must be of a sound, firm nature and any loose areas should be removed prior to application. Any voids or hollow areas should be filled or dubbed out prior to application. Where necessary a fungicide wash should be applied to the wall surface. Platon Plaster Base is for internal use only on walls and curved soffits and is compatible with other Platon membranes. Platon Plaster Base is not recommended for external application and should not be used on floors.

Platon Plaster Base membrane is fixed to walls with the Platon Plaster Plug. The Plaster Plugs should be prepared for use before fixing by wrapping Platon Sealing Rope around the neck of plug just under the head. This will form a seal with the membrane when the plug is driven home into the substrate.

If the ceiling height is constant, measure and cut drops of the membrane to completely cover the wall areas to be treated. Place the membrane against the wall as level as possible by eyesight. In the top right or left hand corner (depending on which way around the room the membrane is being taken) drill a hole, 3 studs in from the edge through the centre spacing between 4 studs, not through the stud itself. Use an 8mm drill bit and insert the Plaster Plug and hammer home until it finishes flush with the membrane. (See fig 22)

Using a spirit level, level out the membrane and pull taut, then drill and fix another Plaster Plug in the same manner at the other top edge of the sheet. Offer up the next length of membrane and position the membrane so that this sheet overlaps by a minimum of (2) studs over the first sheet and fix with two Plaster Plugs at high level as previously described. Continue on in this manner, ensuring the membrane stays as level as possible until all the walls are covered. These independent membrane drops will relax after a while and hang flatter to the wall. The drops are now ready for the next step.

Down the overlap joint, fix Platon Plaster Plugs through the studs as close as possible to the edge of the overlapping membrane. Fixings should be made at 150mm centres along this joint. Continue fixing the Plaster Plugs in a diamond pattern through the centre spacing between the 4 studs until sufficient fixings have been installed, 'minimum 13/m²'.

The membrane must fit tight against the structure with no voids or hollow areas left between the wall and the membrane, as this could cause bonding problems between the membrane and the plaster/render. Care should also be taken at corners to ensure the membrane is fitted tightly into the corner so to avoid snagging or tearing with a trowel.

Once all fixings are in place, clean the membrane surface thoroughly along the overlap joint and ensure it is dry and free from dust. Apply Platon Fleece-back Overtape along the joint with equal overlaps onto each sheet of membrane and press firmly into place. Platon floor membrane can now be laid over the completed drainage system. Wall/Floor Junction, Corner Strip or a creased upstand is always placed in front of the Plaster Base membrane and sealed on the perimeter with Platon Sealing Tape or Rope. If the plaster finish is required to extend down to the finished floor and therefore over the wall/floor junction or corner strip or upstand, Platon Fleece-back Overtape will need to be applied to provide a key for plastering.

3.1 Finishes

Most common lightweight and renovating plasters (Triton Renovating Plaster) or sand/cement renders can be applied to Platon Plaster Base. (The use of British Gypsum Hardwall or Tuff Coat is not recommended).

When using sand/cement render, mixes of 1 part cement to 6 parts washed plastering sand, incorporating either Triton SBR or hydrated lime should be used. NB Grade 'M'; medium sharp sand should be used. Do not use soft or building sand.

All render/plasters should be applied in a minimum of two coats, allowing the first coat of 7mm – 10mm to be trowelled firmly into the membrane studs and then scratched to provide a key for subsequent coats to be applied. The first scratch coat should be left to cure and harden. Ideally this should be 7 – 10 days depending on site and atmospheric conditions. The minimum plaster thickness should be 15mm and the maximum thickness (sand/cement 30mm) (lightweight plasters 40mm). Plasterboard can also be dot and dabbed onto the plasterbase as a fast track system, using board adhesive.

3.2 Fixing through Plaster Base after Plastering or Rendering

On occasions where a fixing is required through the membrane, any one of the three fixing methods set out below can be used to achieve this.

3.21 By using a Platon brick plug with Platon rope seal.

First mark out on the plaster surface where the fixing is required and then place the head of the brick plug over the mark and draw a pencil line around the circumference of the head. Drill a 10mm hole through the centre and carefully scrape/scratch out the plaster within the pencil line back to expose the membrane. Blow out the debris, insert the brick plug and hammer the plug home so that the head of the plug sits flush with the membrane surface.

3.22 By using a rawl plug.

Simply drill a hole through the plaster and membrane and clean debris from the hole. Fill the hole with Triton epoxy resin, allowing the resin to ooze out slightly onto the plaster surface and insert the rawl plug and allow to harden.

3.23 By using contact adhesive and timber batten.

As before, mark out where fixing is required and remove any setting coat plaster. Apply triton epoxy resin to the surface area and to the timber batten and press the batten into position. Some temporary support may be required until the timber has fully bonded.

4.0 PLATON DOUBLE DRAIN MEMBRANE APPLICATION – (For external applications only)

The material can be fitted either vertically or horizontally and therefore would depend on the size of the job as to which option is chosen. It is considered far more economical to fit the product horizontally.

4.1 Wall Preparation

The wall surfaces must be clean and free from cavities and protruding sharp objects. Where protruding ribs or foundation toes occur, a concrete/sand and cement filler piece should be cast/formed to prevent water gathering or laying against the foundation slab.

Apply a bitumen primary membrane to the walls and foundation toe, with a minimum of two coats and allowing 24 hours drying time between each coat.

4.2 Membrane Installation

Starting at the base of the walls, roll out the Platon double drain horizontally against the wall with the filter fabric outwards and fix the Fixing Cramps along the top edge only at 250mm centres. The membrane is hung down the walls like a curtain.

NOTE: If a foundation toe protrudes out from the wall, then the membrane should be extended over the horizontal section of the toe and down the vertical edge.

Continue fitting the membrane horizontally as described above around all walls. Where the next roll/sheet of membrane is to be joined at the vertical edge, carefully peel back the filter fabric from the membrane to be overlapped by approximately 120mm. Platon Sealing Rope is then laid in a vertical line within the channel between the first and second stud and the overlapping section of membrane is then pressed stud to stud to form a seal down the vertical joint.

Once the bottom run of membrane has been fitted horizontally around the walls, the next roll of membrane is also run horizontally in the same manner as above. However, the top membrane overlaps the bottom membrane at the horizontal joint by 120mm. Again the filter fabric is carefully peeled back from the bottom membrane at the joining edge to allow a stud to stud overlap. No sealing rope at this horizontal joint is necessary, but fixing cramps are required at 250mm centres along the joint.

The membrane should be terminated 150mm above external ground level and at this point the Platon Top Edge Mould is fixed using masonry nails. At the base of the wall a graded drainage material should be laid incorporating a geo-textile perforated land drainage pipe. The size of this pipe will need to be determined by the project engineer. Once the drainage pipe is in place, it should be water tested before being concealed with graded backfill/drainage material. We recommend that the external ground be finished with a 1 in 50 gradient away from the walls.

Finally, compaction of back-fill should be conducted with care to avoid damaging the membrane, and direct tipping from lorries should be avoided.

5.0 TRITON SUMP AND PUMP INSTALLATION – AQUA PUMP PRO RANGE

5.1 Aqua Pump Pro™

The Aqua Pump Pro™ is specially designed for the removal of groundwater from basement cavity drainage membrane systems. The system comprises of a polyethylene tank, locking access cover (pedestrian duty, not suitable for roadways) and powerful submersible pump. The system is very versatile, enabling the installer to locate inlets to their specifications.

5.2 Aqua Pump Pro Plus™

The Aqua Pump Pro Plus™ is specially designed for the removal of groundwater from basement cavity drainage membrane systems. The system comprises of a polyethylene tank, locking access cover (pedestrian duty, not suitable for roadways) and two powerful submersible pumps. The system is very versatile, enabling the installer to locate inlets to their specifications.

5.3 Aqua Pump Pro BBPS™

The Aqua Pump Pro BBPS™ is specially designed for the removal of groundwater from basement cavity drainage membrane systems. The system comprises of a polyethylene tank, locking access cover (pedestrian duty, not suitable for roadways), powerful submersible pump and 24V backup pump. The system is very versatile, enabling the installer to locate inlets to their specifications.

The system comes complete with a battery back-up pump system, which is designed especially for where the possibility of primary pump failure through either a pump fault or loss of mains power would be catastrophic. The system acts as a back-up that will alert the end user if the water rises above the normal operating level within the tank and will activate a 24V back-up pump. The system is designed to activate via three separate float switches. The panel contains two batteries that are trickle charged that will keep the back-up system operational in situations of mains power failure and/or pump fault (please refer to section 3.2 'Battery Back-Up Pump System' for details of battery life).

6.0 INSTALLATION GUIDELINES

It is important to note that these instructions are for guidance only and it is the contractor's responsibility to satisfy themselves that the installation procedure is in accordance with the site conditions and good building practice, to eliminate any potential damage to the system either during or after installation. The installer should also satisfy themselves that the system can be installed in conjunction with these guidelines, prior to work commencing.

The tank is manufactured from polyethylene and as such is extremely robust. However, as with any preformed tank they are susceptible to floatation and hydrostatic pressures exerted in high water table conditions.

Please read these instructions in full prior to commencement of the installation. If you are unsure on any point then please ask for advice before proceeding.

Our technical helpdesk is available on 01442 211554 from 8.30 am – 5.30 pm Monday to Friday.

1. Connection of the internal discharge pipe work within the tank is as follows:

Aqua Pump Pro™ **(Single Pump Configuration, supplied as standard)**

Fittings kit comes with the following as standard:

No.	Qty	Description
1	1	PVC 1¼" Tank Connector
2	1	PVC 1¼" Socket Union
3	1	PVC 1¼" Male Threaded Adaptor
4	1	PVC 1¼" Elbow
5	1	PVC 1¼" Class E Pressure Pipe 0.5 metres
6	1	32mm Female Threaded Adaptor

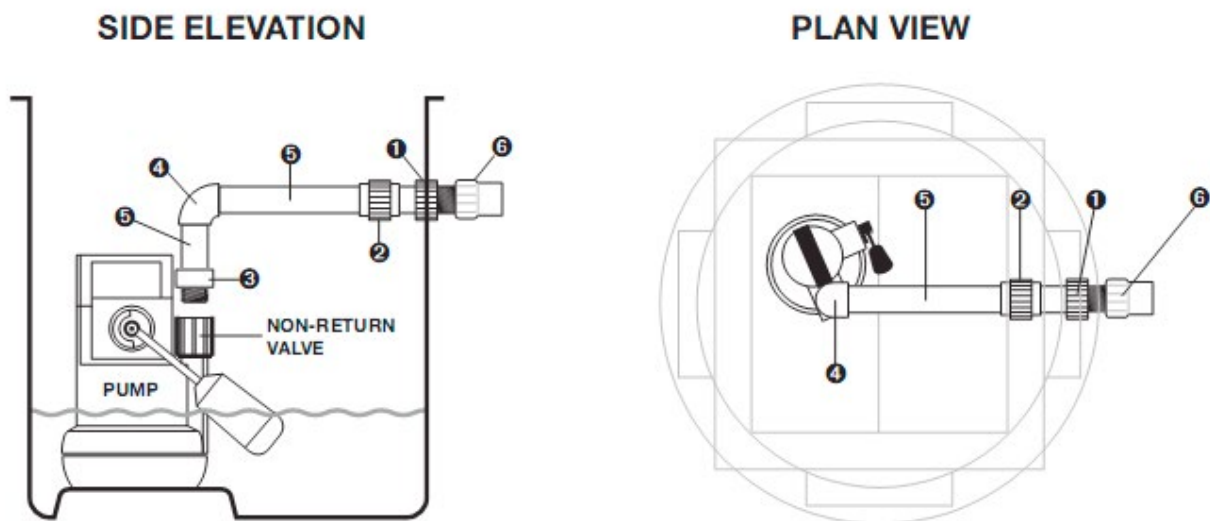

First select a suitable location for the pump ensuring that the float arm is not obstructed by for example the tank wall, inlets etc, at its optimum reach. Remove the nut located in the pump switch and push the float arm into place ensuring that the nut is securely replaced. Prior to installing the internal pipe work please check the Non-Return Valve is securely fixed to the pump outlet and ensure that the flap opens in the direction of the flow.

- Screw the Male Threaded Adaptor (3) into the Non-Return Valve located on the pump outlet.
- Cut a short length of 1¼" PVC pipe (5) and place into the Male Threaded Adaptor (3) (do not glue into place yet).

- c) Place the Elbow (4) onto the short length of pipe (5) and check the height at which the pipe work will leave the tank and mark it where the Tank Connector (1) is to be connected (do not glue the Elbow (4) into place yet). Please note that the pump is to be located on the step.
- d) Drill a 1¼" (44mm) hole where you have marked the tank and fix the Tank Connector (1) in place with the threaded part external to the tank.
- e) Place the Socket Union (2) over the plain end of the Tank Connector (1) (internal within the tank) and position the pump so that there is room for the float switch to activate.
- f) Now measure the length of PVC pipe (5) required between the Elbow (4) and the Socket Union (2) and cut to size.
- g) Check all the pipe work is in place correctly and glue together with plenty of PVC Solvent Cement.

For connection of the external pipe work you will be left with a 1¼" male thread on the outside of the tank, we recommend that you use 1¼" Class E PVC Pressure Pipe but should the installer wish to use 32mm Solvent Weld Waste Pipe (white) then a 32mm Female Threaded Adaptor (6) is supplied within the fittings kit which should be threaded onto the male thread on the outside of the tank.

Aqua Pump Pro Plus™

(Twin Pump Configuration 'Twin Discharge', not supplied as standard need to purchase additional pipe work kit).

Fittings kit comes with the following as standard:

No.	Qty	Description
1	2	PVC 1¼" Tank Connector (*x1)
2	2	PVC 1¼" Socket Union (*x1)
3	2	PVC 1¼" Male Threaded Adaptor (*x1)
4	2	PVC 1¼" Elbow (*x1)
5	2	PVC 1¼" Class E Pressure Pipe 0.5 metres (*x1)
6	2	32mm Female Threaded Adaptor (*x1)

* Items listed to be supplied within 'Twin Pump Fittings Kit – Twin Discharge'

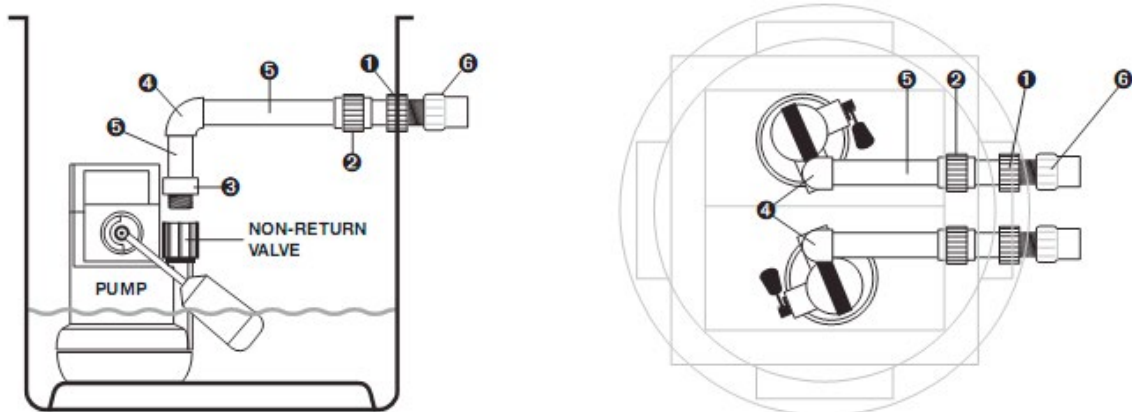

First select a suitable location for the pumps ensuring that 1no. pump is positioned on the base of the tank and 1no. pump is positioned on the raised section. It is also essential to position the pumps so the float arms are not obstructed by for example the tank wall, inlets etc, at their optimum reach (see diagram above). Remove the nut located in the pump switch and push the float arm into place ensuring that the nut is securely replaced. Prior to installing the internal pipe work please check the Non-Return Valves are securely fixed to the pump outlets and ensure that the flap opens in the direction of the flow.

- a) Screw the Male Threaded Adaptors (3) into the Non-Return Valves located on the pump outlets.
- b) With the pumps roughly in position cut a short length of 1½" PVC pipe (5) and place into the Male Threaded Adaptor (3) of the pump on the raised section. Check the height is approximately at the level of the discharge (do not glue into place yet). With the other pump on the base of the tank, measure from the inner lip of the Male Threaded Adaptor (3) to the top of the 1 ½" PVC pipe in position on the raised section. Cut a length of 1 ½" PVC pipe to size and place in to the Male Threaded Adaptor (3) of the pump on the base of the tank ensuring that both lengths of 1 ½" PVC Pipe (5) are the same height.
- c) Place the Elbows (4) onto the short lengths of pipe (5) and check the height at which the pipe work will leave the tank and mark it where the Tank Connectors (1) are to be connected (do not glue the Elbows (4) into place yet). For ease of installation please ensure to leave enough space between the Tank Connectors and they are positioned at a level height.
- d) Drill 2no. 1½" (44mm) holes where you have marked the tank and fix the Tank Connectors (1) in place with the threaded part external to the tank.
- e) Place the Socket Unions (2) over the plain end of the Tank Connectors (1) (internal within the tank) and position the pumps so that there is room for the float switches to activate.
- f) Now measure the lengths of PVC pipe (5) required between the Elbows (4) and the Socket Unions (2) and cut to size.
- g) Check all the pipe work is in place correctly and glue together with plenty of PVC Solvent Cement.

For connection of the external pipe work you will be left with a 1½" male thread on the outside of the tank, we recommend that you use 1½" Class E PVC Pressure Pipe but should the installer wish to use 32mm Solvent Weld Waste Pipe (white) then a 32mm Female Threaded Adaptor (6) is supplied within the fittings kit which should be threaded onto the male thread on the outside of the tank.

Aqua Pump Pro BBPS™

(BBPS Pump Configuration 'BBPS Discharge', not supplied as standard need to purchase additional pipe work kit).

Fittings kit comes with the following as standard:

No.	Qty	Description
1	2	PVC 1¼" Tank Connector (*x1)
2	2	PVC 1¼" Socket Union (*x1)
3	2	PVC 1¼" Male Threaded Adaptor (*x1)
4	3	PVC 1¼" Elbow (*x2)
5	2	PVC 1¼" Class E Pressure Pipe 0.5 metres (*x1)
6	2	32mm Female Threaded Adaptor (*x1)
7	3	PVC 1¼" PI/Th Barrel Nipple (*x2)

* Items listed to be supplied within 'BBPS Pump Fittings Kit – Twin Discharge'

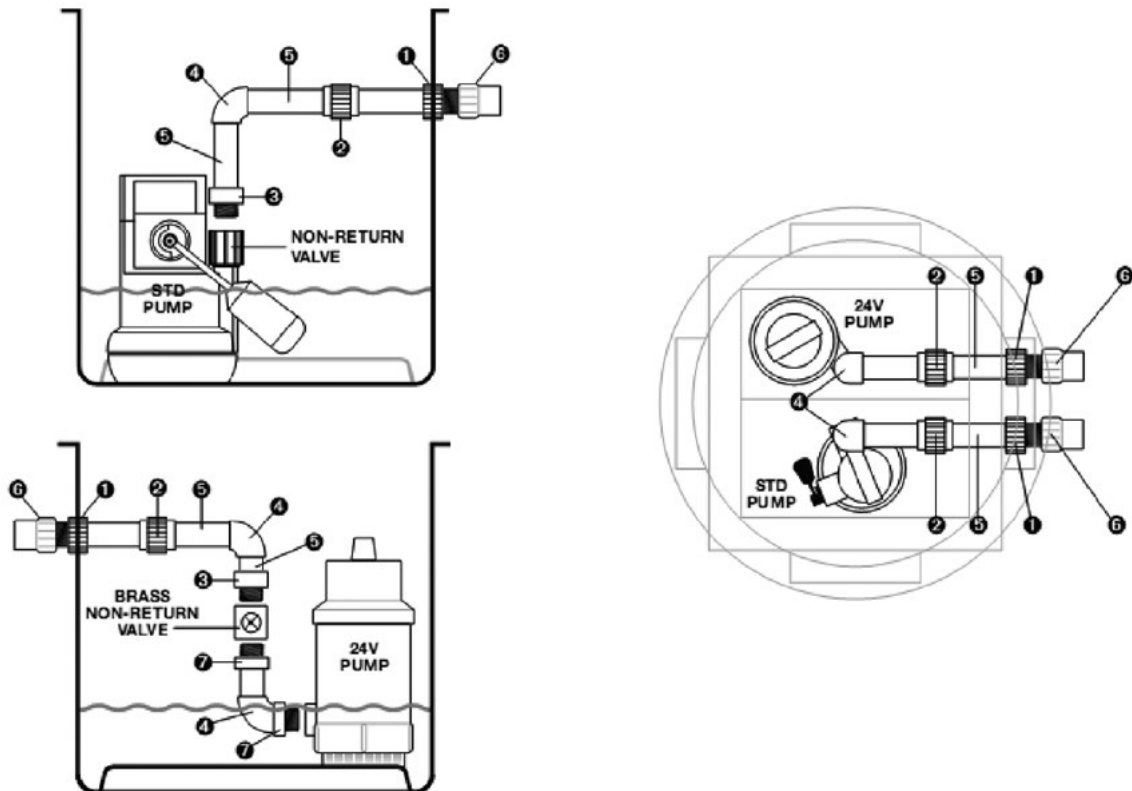

Primary pump pipe work guidelines

First position the Primary pump on the base of the tank ensuring that the float arm is not obstructed by for example the tank wall, inlets etc, at its optimum reach. Remove the nut located in the pump switch and push the float arm into place ensuring that the nut is securely replaced. Prior to installing the internal pipe work please check the Non-Return Valve is securely fixed to the pump outlet and ensure that the flap opens in the direction of the flow.

- Screw the Male Threaded Adaptor (3) into the Non-Return Valve located on the pump outlet.
- Cut a short length of 1¼" PVC pipe (5) and place into the Male Threaded Adaptor (3) (do not glue into place yet).

- c) Place the Elbow (4) onto the short length of pipe (5) and check the height at which the pipe work will leave the tank and mark it where the Tank Connector (1) is to be connected (do not glue the Elbow (4) into place yet). Please note that the pump is to be located on the step.
- d) Drill a 1 $\frac{1}{4}$ " (44mm) hole where you have marked the tank and fix the Tank Connector (1) in place with the threaded part external to the tank.
- e) Place the Socket Union (2) over the plain end of the Tank Connector (1) (internal within the tank) and position the pump so that there is room for the float switch to activate.
- f) Now measure the length of PVC pipe (5) required between the Elbow (4) and the Socket Union (2) and cut to size.
- g) Check all the pipe work is in place correctly and glue together with plenty of PVC Solvent Cement.

BBPS Pipe work Guidelines

- a) Screw 1no. 1 $\frac{1}{4}$ " PI/Th Barrel Nipple (7) into the 24v Pump and then place the 1 $\frac{1}{4}$ " PVC Elbow (4) over the Barrel Nipple with the Elbow pointing directly upwards.
- b) Now take the 1 $\frac{1}{4}$ " Brass Non-return Valve and note the arrow on the side pointing in the direction of the flow. Screw a 1 $\frac{1}{4}$ " PVC PI/Th Barrel Nipple (7) into the bottom of the Valve and 1no. 1 $\frac{1}{4}$ " PVC Male Th. Adaptor (3) into the top of the Valve.
- c) Place the Valve into the 1 $\frac{1}{4}$ " PVC Elbow positioned on the pump and position the 24v Pump on the base of the tank. Measure from the inner lip of the Male Threaded Adaptor (3) to the top of the 1 $\frac{1}{4}$ " PVC pipe on the Primary pump. Cut a length of 1 $\frac{1}{4}$ " PVC pipe to size and place in to the Male Threaded Adaptor (3) of the pump on the base of the tank ensuring that both lengths of 1 $\frac{1}{4}$ " PVC Pipe (5) are the same height.

Place the Elbow (4) onto the short length of pipe (5) and check the height at which the pipe work will leave the tank and mark it where the Tank Connector (1) is to be connected (do not glue the Elbow (4) into place yet). Please note that the pump is to be located on the step.

- d) Drill a 1 $\frac{1}{4}$ " (44mm) hole where you have marked the tank and fix the Tank Connector (1) in place with the threaded part external to the tank.
- e) Place the Socket Union (2) over the plain end of the Tank Connector (1) (internal within the tank) and position the pump so that there is room for the float switch to activate.
- f) Now measure the length of PVC pipe (5) required between the Elbow (4) and the Socket Union (2) and cut to size.
- g) Check all the pipe work is in place correctly and glue together with plenty of PVC Solvent Cement.

For connection of the external pipe work you will be left with a 1 $\frac{1}{4}$ " male thread on the outside of the tank, we recommend that you use 1 $\frac{1}{4}$ " Class E PVC Pressure Pipe but should the installer wish to use 32mm Solvent Weld Waste Pipe (white) then a 32mm Female Threaded Adaptor (6) is supplied within the fittings kit which should be threaded onto the male thread on the outside of the tank.

2. Select a suitable location for the pumping station. It is extremely important to site the system with permanent access in mind for routine maintenance of the system.
3. Prepare the tank for all connection, incoming pipe/s (inlets and cable duct). To do this you must select the location and drill the appropriate sized inlet suitable for your incoming pipe/s (fitting not supplied as standard, see section '6.0 Accessories' for inlet rubber seals).

4. In all instances the tank MUST be positioned on a flat, level, concrete base of dimensions sufficient to fully support the base of the tank. Simply lay clean hardcore to the base of the excavation ensuring that it is consolidated to a thickness of 100mm, then lay a mass concrete to a thickness adequate for the ground conditions and of minimum 150mm thickness, on top of the hardcore.

Carefully position the tank onto the WET concrete base ensuring that no loose debris is inadvertently knocked onto the base, under the tank during this procedure. Push the tank into the wet concrete by 50mm ensuring that the concrete is fully imbedded into the bottom of the tank. Position it such that the inlet, outlet and cable duct pipe work is correctly aligned.

5. Once the tank is positioned connect the incoming pipe/s (inlets and cable duct) to the tank.
6. It is recommended that an external 1¼" gate valve (see section '6.0 Accessories') be installed on the discharge line should the vertical lift exceed 3 meters and/or the discharge line be connected to a foul water outlet.
7. The electrical cables should be now drawn through a cable duct back to the electrical source via a 50mm rubber fitting (fitting not supplied as standard, see section 6.0 Accessories).
8. In all applications the tank must be backfilled with a mass concrete mix of a minimum 150mm thickness and used in accordance with the ground conditions ensuring that it is as dry as practical to prevent additional floatation pressures being exerted on the tank.

The tank MUST be ballasted with water at the same rate as backfilling such that the level difference between the water and the backfill does not exceed 150mm at any time.

Please ensure that when pouring the concrete backfill, suitable steps are taken to prevent the concrete entering the tank and any incoming/discharge pipe work.

9. Where groundwater is present in the excavation, local de-watering of the ground must be undertaken throughout the installation procedure until the backfill has cured. Please note that the ballast water inside the tank should not be removed until the backfill has fully cured.
10. It is extremely important that once the tank has been installed and all the inlet connections made, before the pump/s are installed, the system is flushed through and all sand, silt, rubble and general debris removed from the tank. FAILURE TO DO THIS WILL INVALIDATE THE WARRANTY ON THE PUMP/S.

6.1 Electrical Connection

A qualified person in accordance with the Institute of Electrical Engineers Regulations should connect the Pump/s to the mains supply taking into account all the electrical information provided.

1. Each 240V pump should be connected to a 230V 5A fused spur.
2. Please ensure that there is suitable slack on the cable to allow for the pump/s to be removed for maintenance.

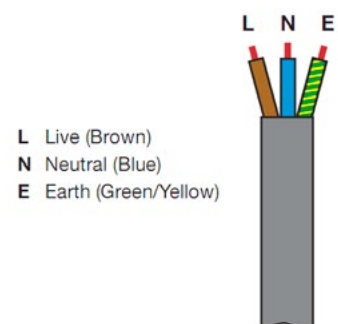

6.2 Battery Back-Up Pump System

6.2.1 Electrical Connections

A qualified person in accordance with the Institute of Electrical Engineers Regulations should connect the unit to the mains supply taking into account all the electrical information provided.

1. Select a suitable location for the control panel, taking into account that the panel must be located within 5m of the pump. It is important to bear in mind access to the control panel for maintenance purposes, ensuring it is located in a dry area and the audio alarm is audible to the end user.

2. Mount the panel to a wall or backboard using the mounting points at the back of the panel and appropriate screws and wall plugs (not supplied).
3. The three float switches need to be fixed to the metal bracket using the fittings provided (plastic washer and nut). Place the float switches into position ensuring that the activation arm is down and fixed into position using the plastic washer and nut.

The float switches should be located within the tank ensuring that the following configuration is adhered to:

'Run' Float	Top of bracket
'High Level Alarm'	Float Middle of bracket (float is to be higher than the primary pump float switch).
'Off' Float	Bottom of bracket

4. The electrical/float cables should be drawn through the cable duct back to the control panel.
5. The panel should be connected to a 230V 13A fused spur.
6. For connection to the mains supply it is imperative that the panel is connected to a separate fused spur to that of the primary pump. This is because should a fault occur with the pump and blow its fuse, then the back-up system can still operate.
7. Please ensure that there is suitable slack on the cable to allow for the pump to be removed for maintenance.
8. To commission the control panel you must connect both the batteries using the connectors provided, a red indicator on the battery charger will inform you that the batteries are now charging, once fully charged the red indicator will turn green. To test the system, disconnect power from the primary pump and fill the tank with water until the back-up pump activates. Please note that prior to the back-up pump activating the high level alarm should sound.

6.2.2 Control Panel Operation

The most important element of the battery back-up system is the control panel as it controls and monitors and status of the complete system.

The panel consists of both visual and audio indicators that are imperative for both the installer and end user to fully understand.

Visual Indicators

White Indicator (Supply On)	This indicates whether there is a mains supply connected to the unit. Should the mains supply be removed (i.e. Power failure, blown fuse) the light will go out.
Red Indicator (Fault)	This indicates whether there is a fault with the back-up pump, such as a blockage, blown fuse or that the batteries have run dry.
Green Indicator (Running)	This indicates that the back-up pump is in operation.

Audio Indicators

The battery back-up system comes complete with an audio alarm to alert the user when there is a high level situation within the tank. Also located on the front of the panel is an alarm mute button to silence the alarm in a high level situation.

7.0 TECHNICAL SPECIFICATIONS

7.1 Aqua Pump Pro, Aqua Pump Pro Plus and Aqua Pump Pro BBPS

Model	Aqua Pump Pro, Aqua Pump Pro BBPS	Aqua Pump Pro Plus
Power Supply	230V AC	230V AC
Rated Current	1.5A	1.5A per pump
Motor Rating	340W	340W per pump
Frequency	50Hz	50Hz per pump
Revolutions Per Min.	2800rpm	2800rpm per pump
Max Vertical Output	7m	7m
Max Horizontal Output	50m	50m
Max Flow Rate	132l/m	132l/m
Max Liquid Temp.	<40°C	<40°C
Discharge Size	1¼" / 32mm	2 x 1¼" / 32mm
Cable Length	5m	5m
Weight	9kg	9kg
Colour	Red	Red

7.2 Battery Back-Up Pump System

Power Supply to Panel	230V AC
Power Supply to Pump (via panel)	24V
Frequency	50Hz
Motor Rating	Intermittent
Max. Vertical Output	6.5m
Max. Horizontal Output	45m
Max Flow Rate	180l/m
Max. Liquid Temp.	<40°C
Rated Current	13A
Discharge Size	1¼"
Cable Length	4m
Battery Life	45min

8.0 DIMENSIONS

8.1 Aqua Pump Pro, Aqua Pump Pro Plus and Aqua Pump Pro BBPS

Diameter	550mm
Height	600mm

8.2 Battery Back-Up Panel

Height	380mm
Width	300mm
Depth	180mm

9.0 PARTS LIST

9.1 Aqua Pump Pro, Aqua Pump Pro Plus & Aqua Pump Pro BBPS

Product Name	Aqua Pump Pro & Aqua Pump Pro BBPS (Qty)	Aqua Pump Pro Plus (Qty)
Tank	1	1
Access Cover, Locking, Solid Top 350 x 350mm (Pedestrian Duty)	1	1
Pump	1	2
Float Arm for Pump	1	2
Fittings Kit (Pipe work/Fittings)	1	1
Non-return Valve (integral)	1	2

9.2 Battery Back-Up Pump System

Qty	Product Name
3	Mini Float Switch
1	Control Panel
1	Non-return valve (Brass)
1	24V Back-Up Pump

10.0 ACCESSORIES

Product Name	Product Code
High Level alarm (Mains Operated)	22050
High Level alarm (Mains/Battery Operated)	22051
1½" Brass Gate Valve	10003
110mm Rubber Seal (Drainage Inlet)	17010
50mm Rubber Seal (Inlet/Cable Duct)	17012
12V, 7Ah Battery	14003
Access Cover, Recessed 350 x 350mm	18014

11.0 WIRING DIAGRAMS

Wiring Diagrams can be found within the panel control/s. Should you require further assistance please contact our technical helpdesk on 01442 211554 from 8.30 am to 5.30 pm Monday to Friday.

12.0 TRANSPORT

The pump/s are shipped disconnected from the pipe work and fittings to avoid damaged in transit. Carefully unpack the system from its packaging and inspect for any signs of damage. Should there be any damage present it must be reported immediately (no claim will be considered after 24 hours from time of delivery).

13.0 MAINTENANCE

The system requires minimal maintenance; however it is strongly recommended that the unit is serviced quarterly during the first year. It is essential that the unit is serviced at least annually thereafter.

To clean out the unit you must first turn off the power supply and ensure that it cannot be inadvertently turned back on. (i.e. remove the fuse/s). Now remove the access cover to gain access to the pump/s. Next you must remove the pump/s from the tank by disconnecting the pipe work and lifting the pump/s out. It is advisable to check the underside of the pump/s to ensure there is no build up of debris around the pump/s and the float switch/es as this can often lead to poor pump performance or damage to the pump/s.

You must also clean out the tank ensuring that there is no debris in the bottom of the tank. Now that the tank is clean you must reconnect the pump/s to the pipe work and check the function of the pump/s prior to replacing the access cover.

It is advised that the operation of the battery back-up system is checked every 6 months; this can be done by removing the power supply to the primary pump/s and allowing the tank to fill with water until the back-up pump activates. It is also advised that every 6 months the system is allowed to operate using only the back-up pump, this is to allow the batteries to run down and fully recharge which in turn will help to extend the life of the batteries.

Please note that we recommend that the batteries be replaced every 2 years.

In addition we strongly recommend that a service agreement be taken out, please refer to section 11 for further information.

14.0 HEALTH AND SAFETY

Please pay attention to the following regulations when installing the pump system or ask your qualified electrician/distributor.

Safety Precautions

In order to minimise the risk of accidents in connection with the service and installation work, the following rules should be followed.

- Do not ignore health hazards. Observe strict cleanliness.
- Bear in mind the risk of electrical accidents
- Use a safety helmet, safety goggles and protective shoes.
- All personnel who work with sewage systems must be vaccinated against diseases to which they may be exposed.
- A first aid kit must be close to hand.
- Note that special rules apply to installations in an explosive atmosphere.

Electrical Connections

- The following works should only be done by qualified and authorised electricians.
- Edincare and Triton Chemical Manufacturing Co Ltd disclaim all responsibility for work done by untrained and/or unauthorized personnel.
- Heed operating voltage (see name plate and additional labels).
- Take out the main fuses to isolate the mains supply from the control unit before repairs or any other works and ensure it cannot be energized again.
- As the pump is equipped with an automatic level control, there is a risk of sudden restart.
- Before starting check the efficiency of the protective arrangements of the pump and the monitoring equipment. Failure to heed this warning may cause a lethal accident.
- Do not put the lead ends into water! Irruption of water may cause malfunctions.
- If persons are likely to come into physical contact with the pump or pumped media, the earthed (grounded) socket must have an additional connection to an earth (ground) fault protection device (GFI).
- Use the pump only in accordance to the date stated on the pump's plate.
- Connection only to mains supply installed in accordance to the local regulations. For fusing of D.O.L. starting pumps use only appropriate slow fuses or automatic circuit breakers with D characteristics.

This is because the motor's nominal voltage is measured at the terminal board of the pump; please consider the voltage drop of long supply cables.

- Replace the cable if the cable jacket is damaged. Do not pinch the cable or pull it around sharp bends.
- Always install the control unit in a dry and well ventilated room. Never install the control unit within the tank.

Earthing

For safety reasons, the earth conductor should be approximately 50mm (2") longer than the phase conductors. If the motor cable is jerked loose by mistake, the earth conductor should be the last conductor to come loose from the first terminal. This applies to both ends of the cable. Ensure the correct earthing of the pump and control unit.

15.0 TRITON AQUA CHANNEL

The internal peripheral drainage channel known as Aqua Channel is a P.V.C drainage conduit that has been specifically designed for the control of water ingress in below ground situations. The channel which is pre-formed in a pentagonal shape with pre-drilled 19mm drainage holes set 70mm apart along its length, is fitted around the periphery of an internal floor at the vulnerable wall/floor junction and can be used in most waterproofing situations.

Water enters the channel through the pre-drilled holes and is then diverted to a suitable drainage point, either natural (gravity fed) or mechanical (sump & pump). The channel is particularly suited for use in conjunction with cavity drain membrane. Water entering a building through walls or curved soffits is controlled behind the Cavity Drain Membrane and diverted to the 'Aqua Channel' fitted at the base of the wall.

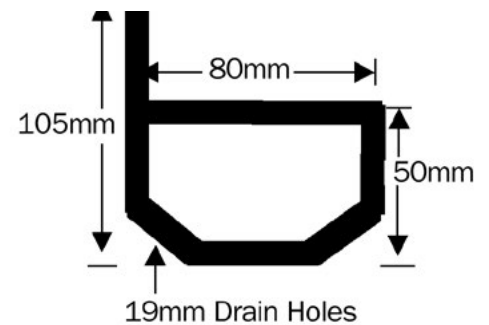

AQUA CHANNEL ACCESSORIES

Channel Outlet

The channel outlet consists of a 90° PVC bend and a PVC male coupling which is fitted to the base of the 'Aqua Channel' to allow water to be taken from the channel to the water collection point i.e. sump and pump. A 40mm diameter hole is cut into the base of the channel and the 90° bend and male coupling is inserted and solvent welded together to form a swivel joint. A 1½" PVC pipe can then be fitted into the channel outlet to link it to the sump and pump or water collection point. The swivel action ability of channel outlet also means flexibility, which is sometimes needed, when one is taking into consideration the positioning of the sump and pump.



Channel End Outlet

Where gravity fed drainage is to be used, the Channel End Outlet has been designed to convert the pentagonal shape of the Aqua Channel into a round aperture. This enables water to be discharged from the Aqua Channel into a 'P' trapped gully or to a soakaway and is fitted to the end of a section of Aqua Channel. A blanking plate made from PVC with a 40mm diameter hole cut through, together with a PVC male coupling and straight connector is solvent welded to the open end of the channel. This then allows for a 1½" PVC pipe to be connected and then extended to the 'P' trapped gully or soakaway. NB the Channel End Outlet should not be used to drain water from the Aqua Channel directly into foul drainage or into a stack pipe. This is because there is a risk of pungent smells emanating into the Aqua Channel peripheral drainage system.

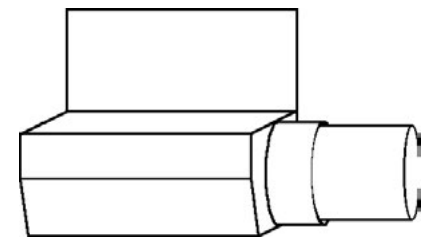

It is not possible to insert a non-return valve, as this cannot operate properly in the horizontal position.

Cleaning Ports

Cleaning Ports (jetting eyes) should be incorporated into the 'Aqua Channel' and can be inserted at any point along its length, to allow for periodic cleaning of the drainage system. A 40mm diameter hole is cut into the top the channel to enable a PVC straight connector with a removable cap and rubber seal to be solvent welded to a male coupling. It is recommended that 1 Jetting Eye (cleaning port) be fitted for every 12 linear metre run of channel installed.

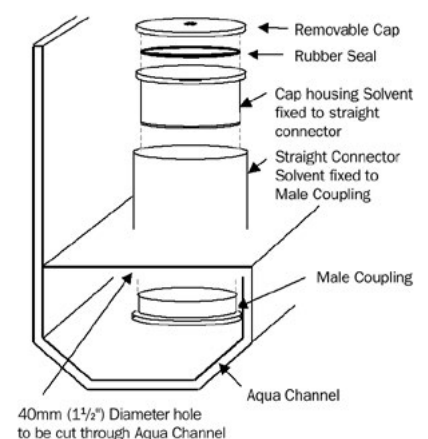

Installation

15.1 Form a trough 130mm deep x 130mm wide in the floor at the wall/floor junction. (See also fig 25)

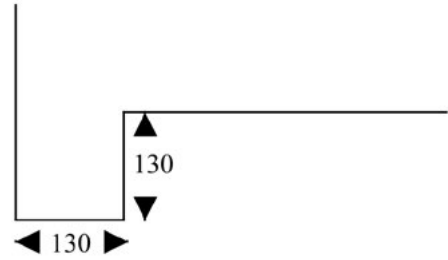

15.2 Apply the waterproof coating or Platon Cavity Drain Membrane to the wall and finish 100mm minimum below existing floor level. (See also fig 26)

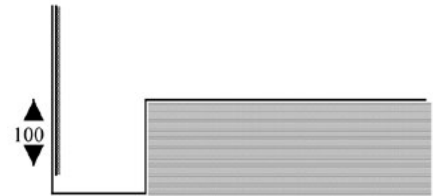

15.3 Lay a shallow bed of 20mm stone into the trough. Place the Triton Aqua Channel onto the stone with the upstand to the top and flat against the waterproofing/cavity drain membrane to the wall. Lengths of Aqua Channel are butt jointed on straight runs and can be mitred in corners. Joints should be sealed with a suitable tape, Platon Over Tape or builders' duck tape, to avoid debris from falling into the channel. (See also fig 27)

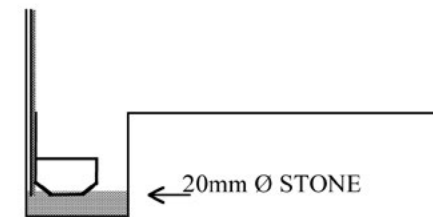

15.4 Fit the Aqua Channel outlet into the Aqua Channel at the appropriate location. The Aqua Channel outlet requires a 40mm hole in the underside of the Aqua Channel. The Aqua Channel outlet is solvent welded to the channel using the internal male coupling. A chase should be formed into the floor to accommodate the outlet pipe from the Aqua Channel to the sump or drain.

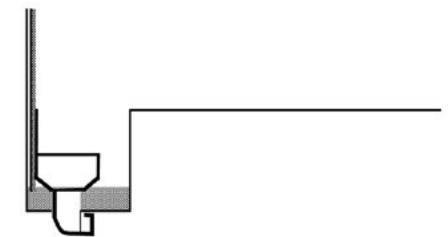

15.5 Infill the remaining gap between the Aqua Channel and the side of the trough with 20mm stone and finish flush with the flat surface of the Aqua Channel. (See also fig 28)

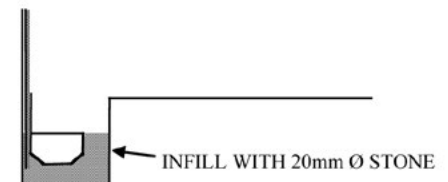

15.6 When installing Platon membrane over the floor, make good the remaining area with 20mm stone. Lay the membrane over the floor area and seal to the wall membrane using Platon Wall/Floor Junction or Platon Sealing Rope.



15.7 When Platon membrane is not going to be installed over the floor, make good the remaining area with approximately 50mm screed.



Maintenance

It is recommended that the Triton Aqua Channel be jet washed via the jetting ports, which should be incorporated in the channel system, at least once every six months. This should be carried out by the installing contractor (under a maintenance contract) or by the property owner. During this cleaning process the pump/s (if installed) should also be run with water out of the sump chamber to ensure they are fully operational and that the sump chamber be cleaned of any sludge/silt that may have accumulated. In addition to this, the high water level battery alarm box and alarm sensor should also be checked for working order.

INSERTING PLATON BRICK PLUG THROUGH MEMBRANE STUD



FIG. 1



FIG. 2

FLANGE TO STUD SEALING TAPE JOINT



FIG. 3

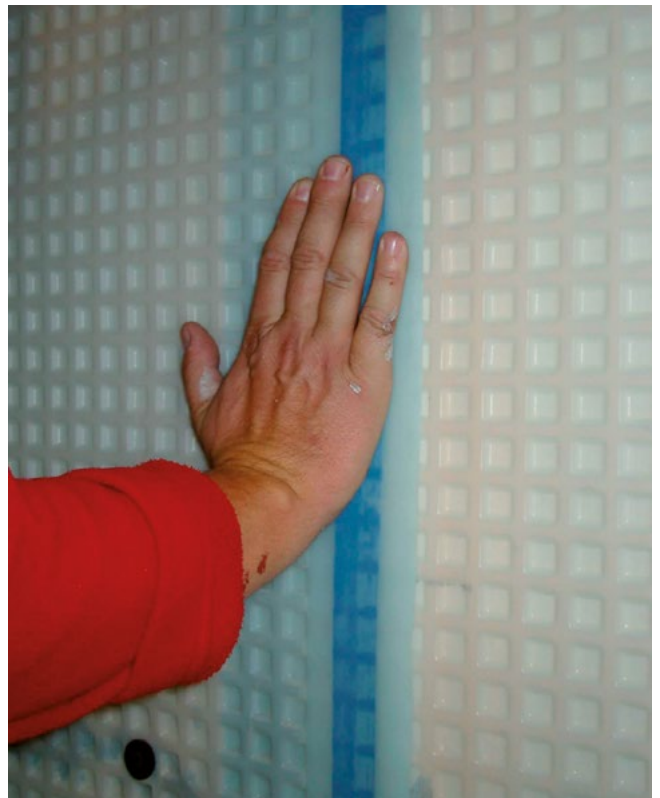

FIG. 4

P20 FLOOR MEMBRANE CUT AROUND PERIMETER WALLS

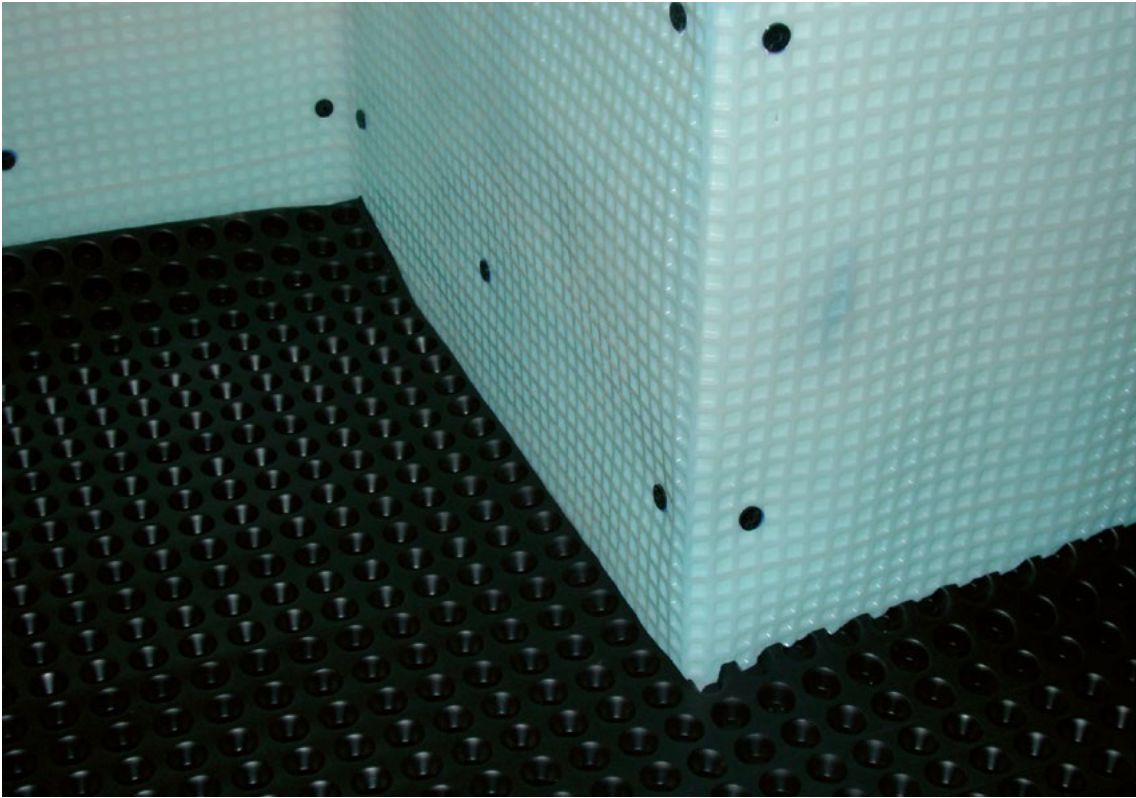

FIG. 5

POSITIONING OF SEALING ROPE BETWEEN TWO STUDS OF THE P20 MEMBRANE

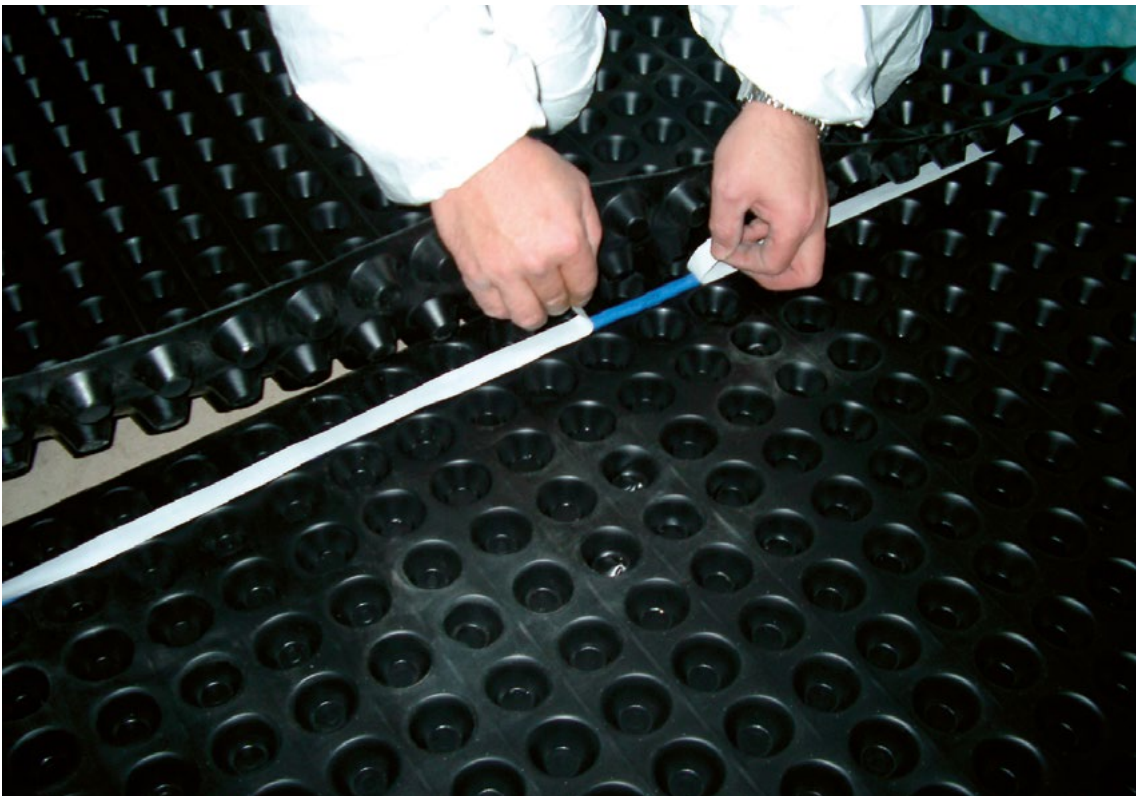

FIG. 6

POSITIONING MEMBRANE STUD TO STUD OVER ROPE SEAL



FIG. 7

PRESS MEMBRANES TOGETHER TO ENSURE BOND



FIG. 8

FORMING 90° ANGLE CREASE IN CORNER STRIP



FIG. 9

CORNER STRIP WITH CREASE OFFERED INTO ANGLE



FIG. 10

CORNER STRIP – ANGLE CUT

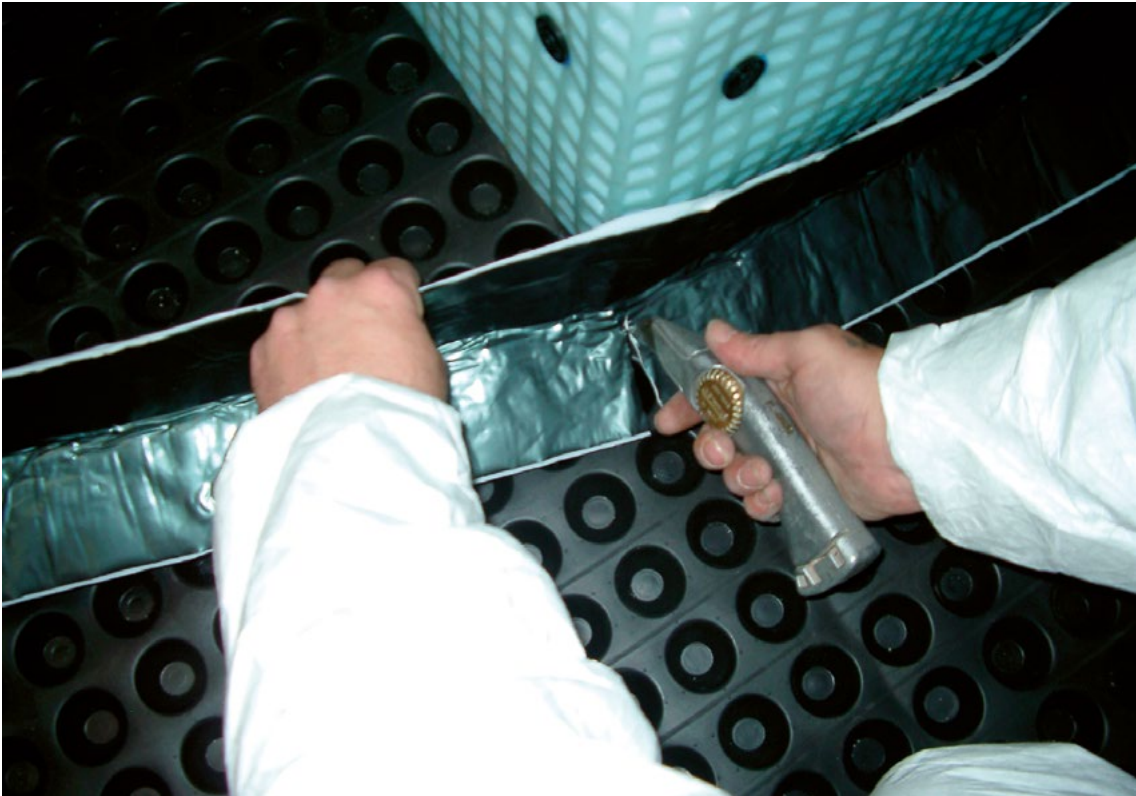

FIG. 11

CORNER STRIP PRESSED INTO POSITION

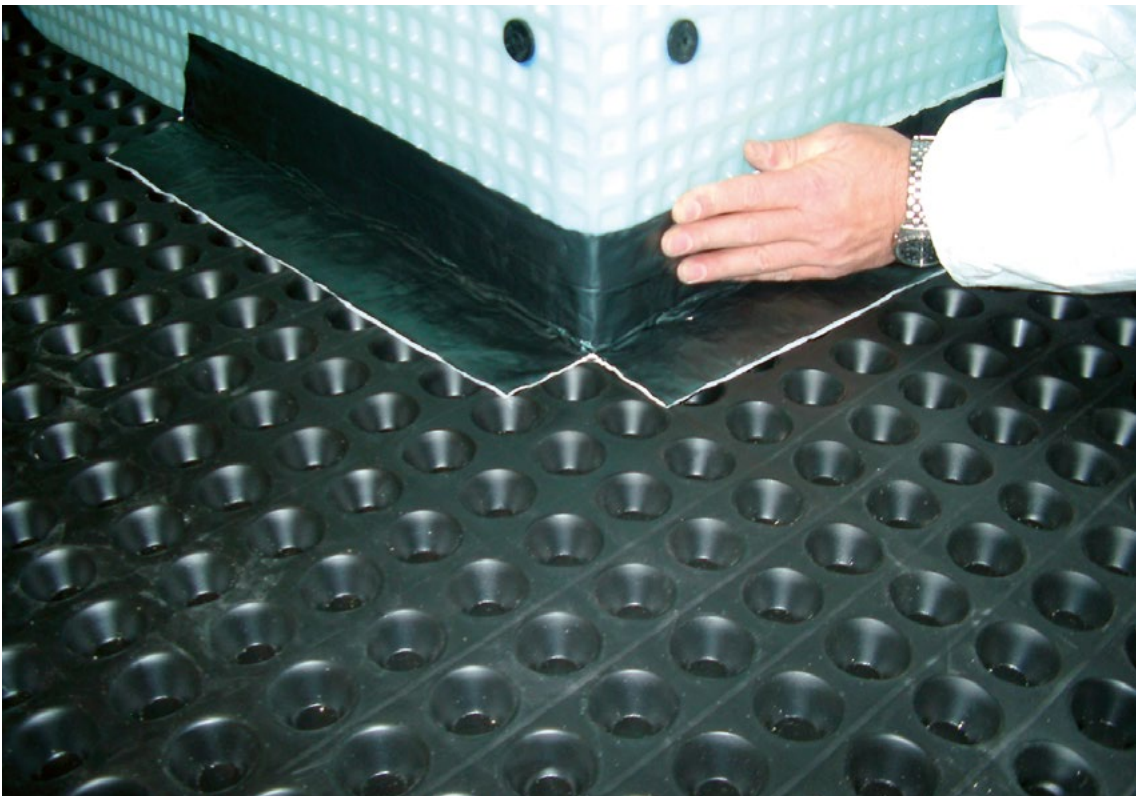

FIG. 12

ANGLE PIECE TO SEAL & COMPLETE CORNER JOINT

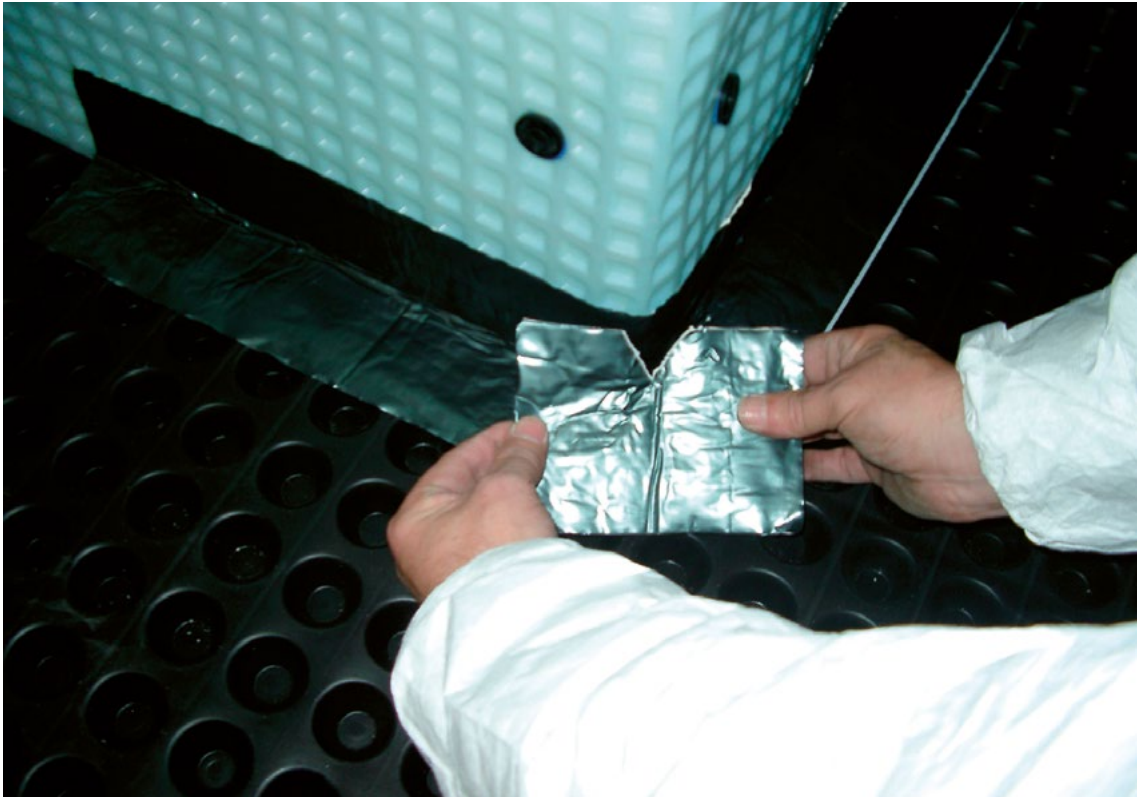

FIG. 13

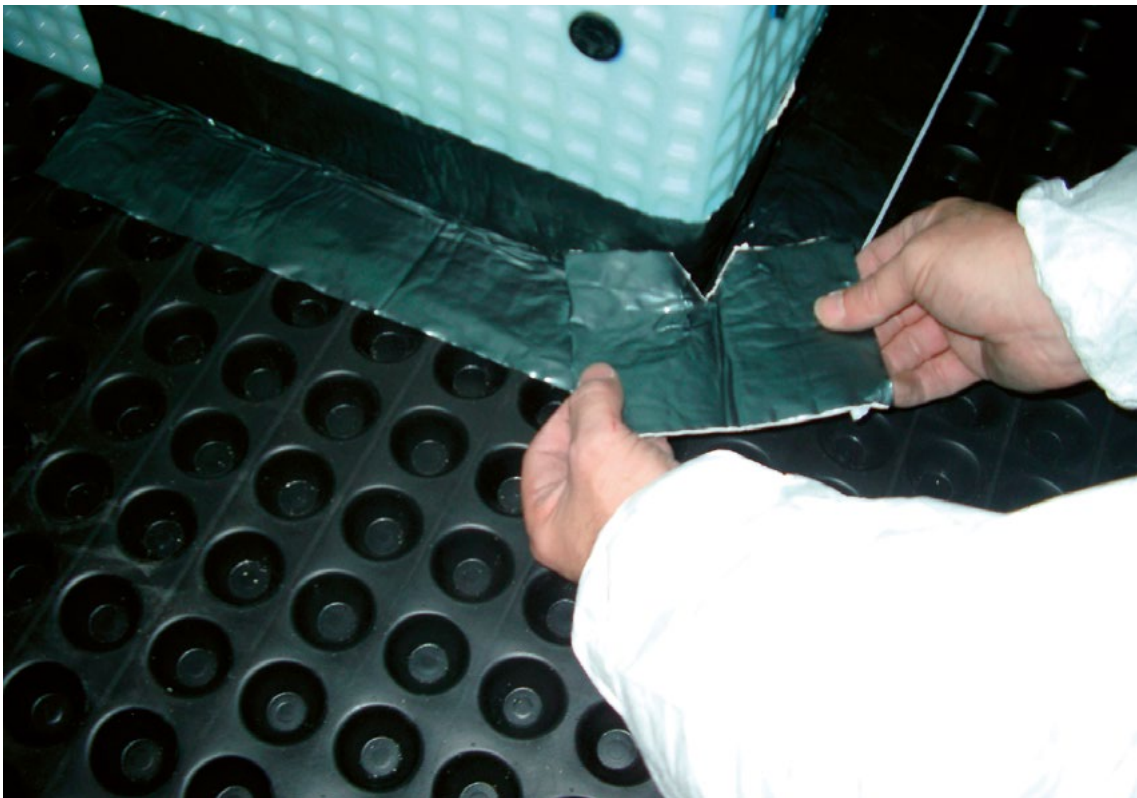

FIG. 14

COMPLETED CORNER STRIP WALL/FLOOR JUNCTION DETAIL

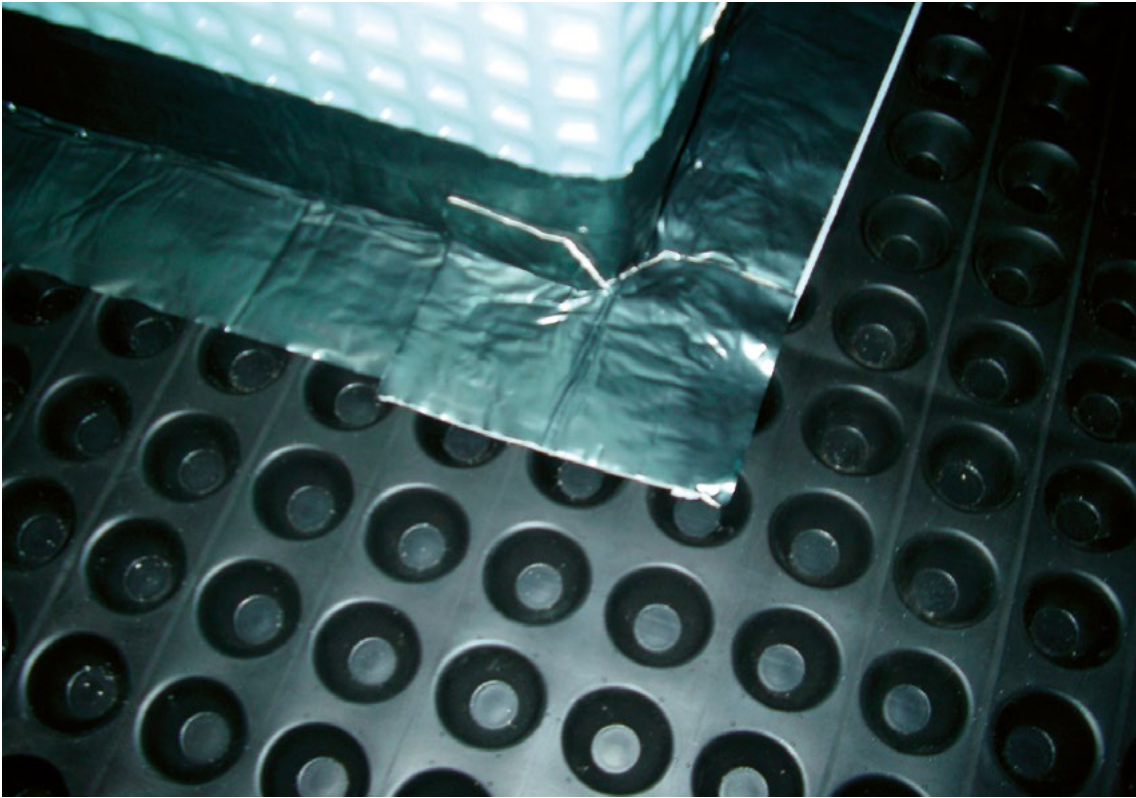

FIG. 15

TAPE SEAL TO SERVICE PIPE DUCTS PROTRUDING THROUGH WALL STRUCTURE AND MEMBRANE



FIG. 16

FIXING PLASTER BASE PLUG BETWEEN 4 STUDS OF THE MEMBRANE

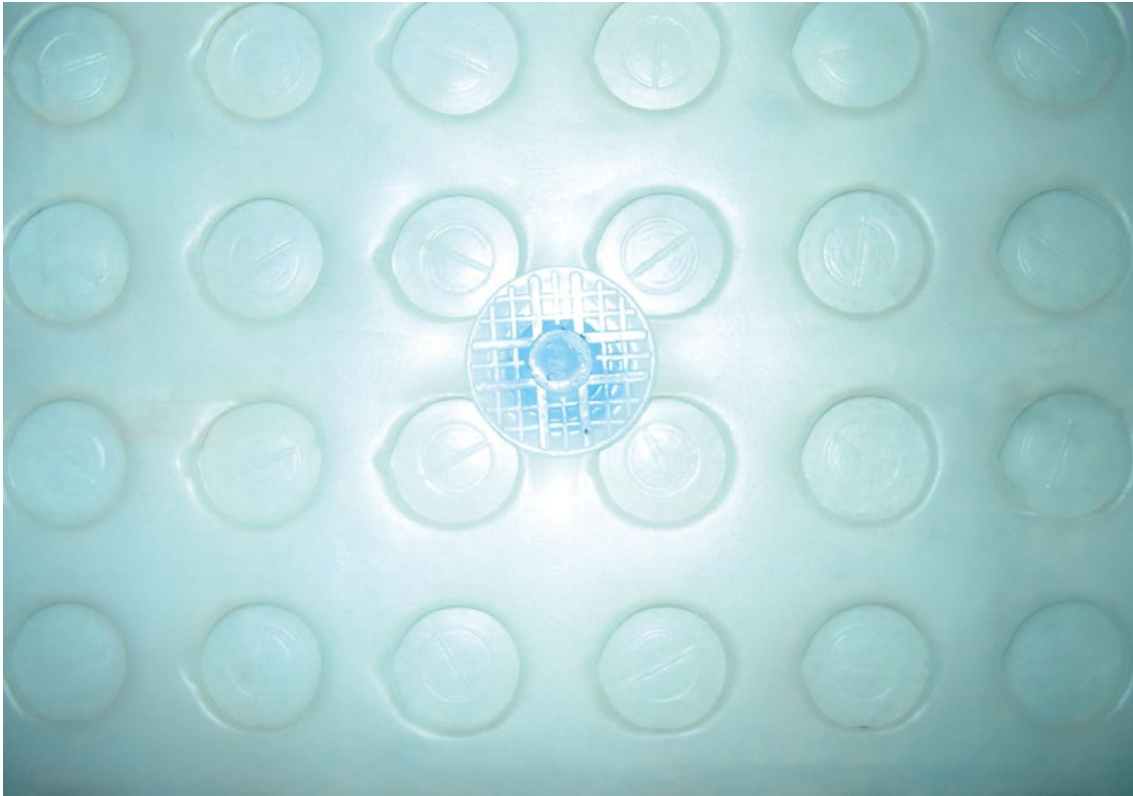

FIG. 17

130MM X 130MM GULLY CAST TO RECEIVE AQUA CHANNEL



FIG. 18

PLATON MEMBRANES INSTALLED TO WALL



FIG. 19

AQUA CHANNEL TO CAST GULLY



FIG. 20

INFILLING TO AQUA CHANNEL AND GULLY WITH AGGREGATE



FIG. 21

AQUA CHANNEL INSTALLATION INCLUDING INSPECTION PORT



FIG. 22

ISOLA BLUEBIRD SCREW TIE

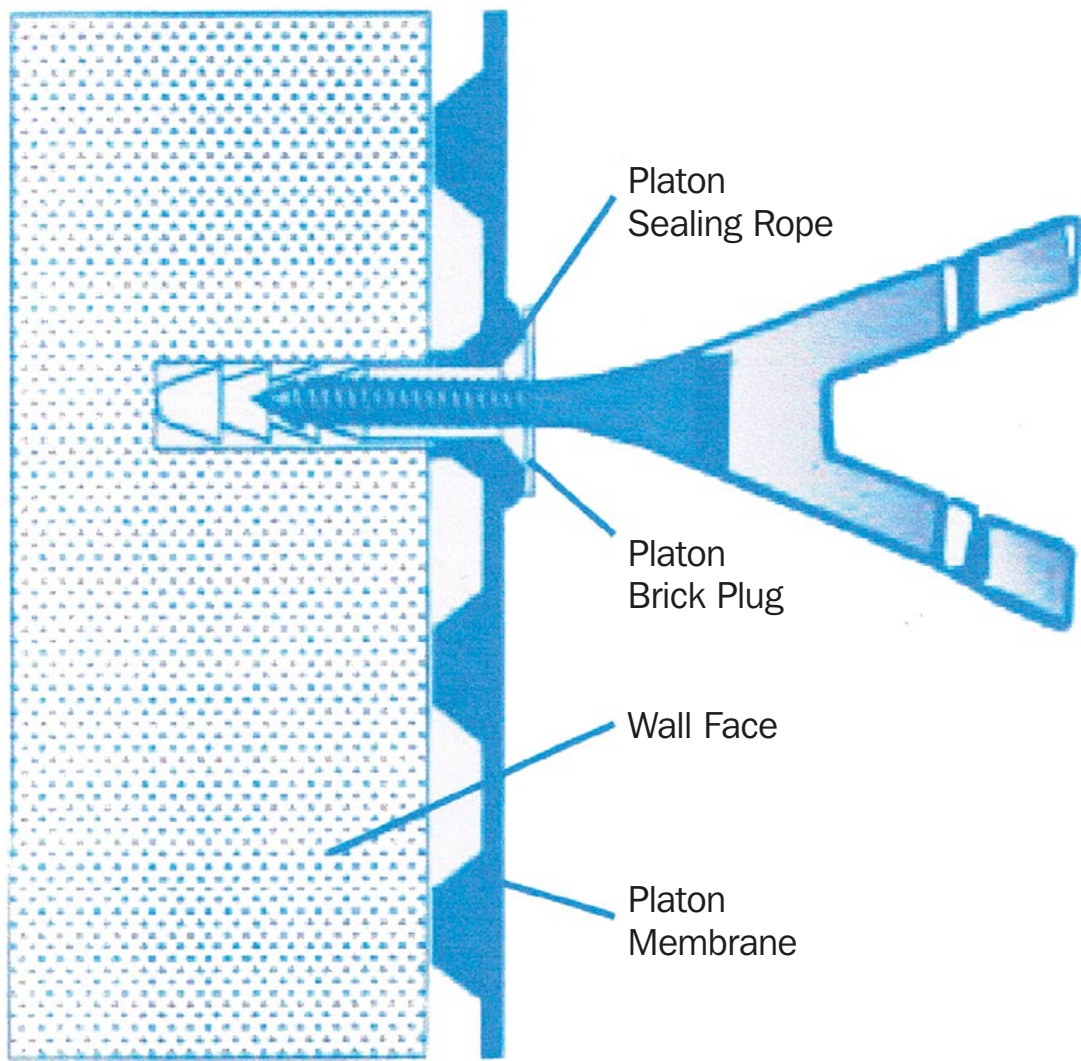

▶ Bluebird Screw Tie to be used in conjunction with System Platon

FIG. 23

Cavity Drain Membrane Systems: Sumps and Pumps: Guidance Notes.

Introduction:

In most cases when installing the Isola Platon cavity drain system the actual level of water ingress or potential level of water ingress is not known. However in accordance with BS 8102 (2009) IT MUST BE ASSUMED THAT WATER WILL INGRESS AT SOME POINT IN TIME. BS 8102 (2009) states that all type 'C' drained protection systems need to be maintainable.

1. Pump Capacity:

If the water ingress is known then the required minimum capacity of the sump and pump system can be easily calculated. The capacity of the sump pump is affected by a number of factors and these need to be taken into account when calculating the capacity of your pump system, these include:

- 1 Internal diameter of discharge pipe.
- 2 Length of discharge pipe.
- 3 Head height (including depth of sump chamber).
- 4 Number of bends / angles in discharge pipe.
- 5 Stated capacity of pump.

Each of the above WILL affect the capacity of the installed pump. All pumps have a stated maximum capacity and maximum stated head that they are able to pump to, manufacturers figures are given for a stated diameter of pipe. Therefore any variations of these and the pumps capacity will be changed.

2. Number Of Sumps:

The number of sumps required will again vary depending on the volume of water ingressing and or anticipated within the system, and the size of the floor area being covered as well as the type of drainage system incorporated into the design specification. In general there should be at least one sump per 50 linear meters of Aqua Channel.

3. Type Of Sump:

The type of sump is also important, perforated sump chamber or non perforated sump chamber. In general either sump chamber may be suitable however where the following site conditions occur then ONLY the non perforated chamber should be installed:

- High water table.
- High perched water table.
- High silt / sediment content in groundwater.
- Risk of de watering where structure maybe undermined.

If there is any concern it is better to install a non perforated chamber or seek further technical assistance (contact Triton technical dept: 01322 318830).

4. Number Of Pumps:

If the level of water ingress is known then the required pump capacity can be calculated taking into account the length of discharge pipe, head height etc.. as indicated in section 1 above. Then it is a simple multiplication of the number of pumps to cope with the required level of ingress (plus a safety factor).The pumps capacity should be at least 2 to 3 times that which is currently required at time of installation.

E.G. If 100 l/min of water is ingressing then pump capacity should be 2-300 l/min, therefore if single pump capacity has been calculated to 50 l/min then four pumps to be included within the system.

As with all mechanical items they are prone to failure and require regular maintenance. Pump failure could either be from mechanical failure, power failure or lack of maintenance. It is for these reasons that it is best practice to install a MINIMUM OF TWO PUMPS PER SUMP CHAMBER. These can either be two 240v mains powered pumps or a mains powered pump and a battery back up pump. Therefore should one pump fail for what ever reason the second pump will take over. This is also true if the level of water ingress increases to such an extent that the first pump cannot cope the second pump will “kick in” to assist.

Thus reducing the risk of the basement flooding!

5. Maintenance:

As previously stated the sumps and pumps need to be maintained, THIS SHOULD BE CARRIED OUT EVERY SIX TO TWELVE MONTHS. A typical pump, sump, and drainage schedule is available from Triton as a guide and is the MINIMUM MAINTENANCE REQUIRED.

It is important that if during a maintenance visit the level of water ingress has increased, and the capacity of the system is near optimum, then under the bounds of “DUTY OF CARE” the client should be advised that the system needs upgrading. This may include changing the pumps for those with a higher capacity, increasing the number of pumps, or increasing the number of sumps and pumps within the system.

As with the ongoing maintenance this is chargeable!

Issues Of “Free-Lime” In Cavity Drain Membrane Systems.

The use of cavity drain systems as method of waterproofing is ever increasing particularly in new build basements and retrofit basements. In accordance with the code of practice BS8102, they need to be maintained. This has been helped significantly with the introduction of perimeter drainage channels and inspection ports, so as to make the drainage aspects maintainable and help to prevent blockages within such as can be caused by the existence of free lime for example.

In most new construction and retrofit basements (and also in refurbishment projects where the floor has been replaced), there is a high risk of “free lime” and / or mineral salts leaching from the concrete walls and floors. In retrofit this is particularly prevalent where “dry pack” is used at the top of the underpinning.

As free lime leaches from the new construction by groundwater ingress it deposits itself within the drainage cavity, (behind and underneath membranes) and particularly within the sump chamber and around the sump pumps. Thus potentially causing pump failure and therefore failure of the cavity drain system.

Maintenance of the cavity drain system and its discharge points is vitally important to the long term success of the system, with the recommended maintenance interval being 6 months. (refer to Triton's typical pump maintenance schedule).

The impact of free lime within the cavity drain system would greatly increase the frequency of maintenance over the first 3 – 5 years, reducing the interval to weeks in some instances, thus increasing both the costs of maintaining the system and also putting the system under undue risk.

In order to minimise the risk of free lime impacting on the cavity drain system, an “anti lime” coating should be applied to the concrete, such as TT Vapour membrane or TT Super. As shown in diagram TT009.1 (see page 39). For retrofit basements or where underpinning is being used we refer to drawing no. IP034.1 (see page 40).

This will not only reduce the amount of free lime leaching into the cavity drain system but also will improve the water resistance of the basement structure, which in turn reduces the risk to the cavity drain system.

For further information on Triton's anti lime products or for assistance on designing these into a cavity drain system contact Triton's technical department on 01322 318830.

Long term benefits include significantly reducing the risks to the cavity drain system and saving maintenance costs, see examples opposite.

Example:

1. Existing basement with internal cavity drain system incorporating two sumps each with double pump system, maintained every six months.

Average cost of maintenance – approx £200 / sump / visit = £800 / annum

Over 10 years: £8,000 (minimum).

2. New build basement (concrete) with similar internal cavity drain system as above:

Maintained every 3 months in first 3 years, every 4 months in years 4 & 5, thereafter every six months:

Average cost of maintenance – £200 / sump / visit

Years 1, 2 & 3 = £1600 / year

Years 4 & 5 = £1200 / year

Years 6 – 10 = £800 / year

Total maintenance cost for 10 years = £11,200 (minimum).

NOTE: A suitable Anti-Lime coating will dramatically reduce the associated problems of Free-Lime, whilst also dramatically reducing lime scale build up within both the drainage conduits and sump pump components.



Typical problems caused by lime deposits

DIAGRAM TT009.1

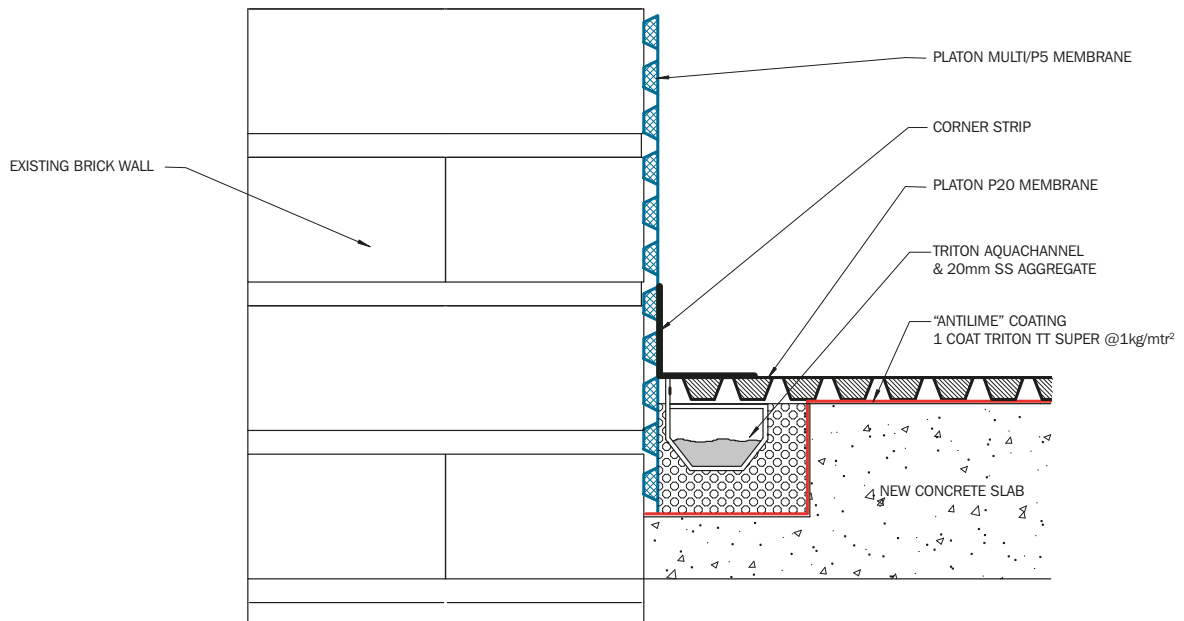
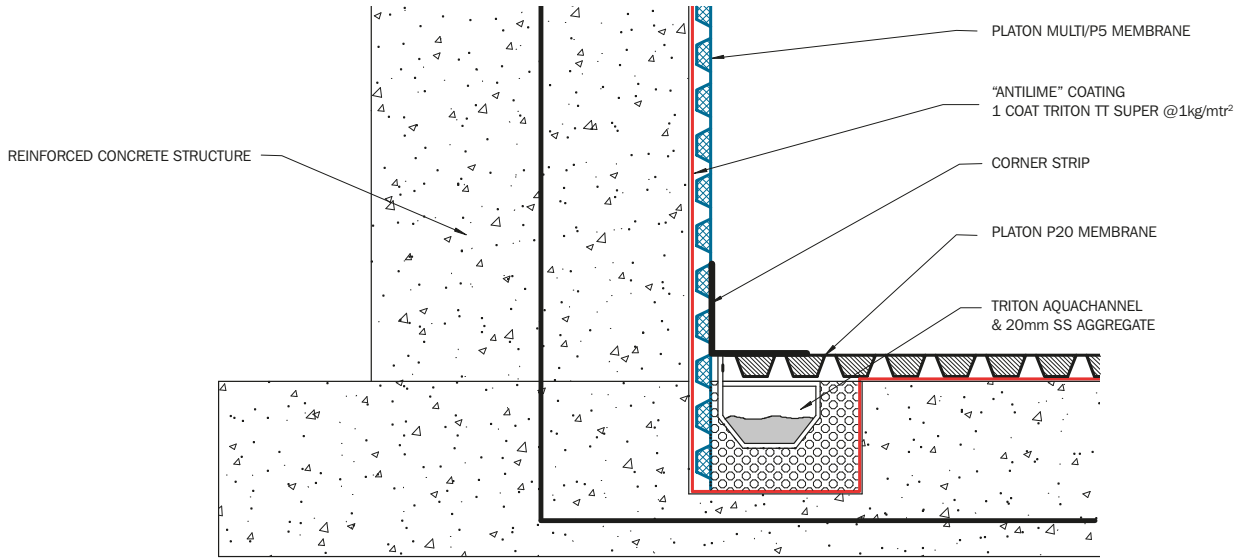
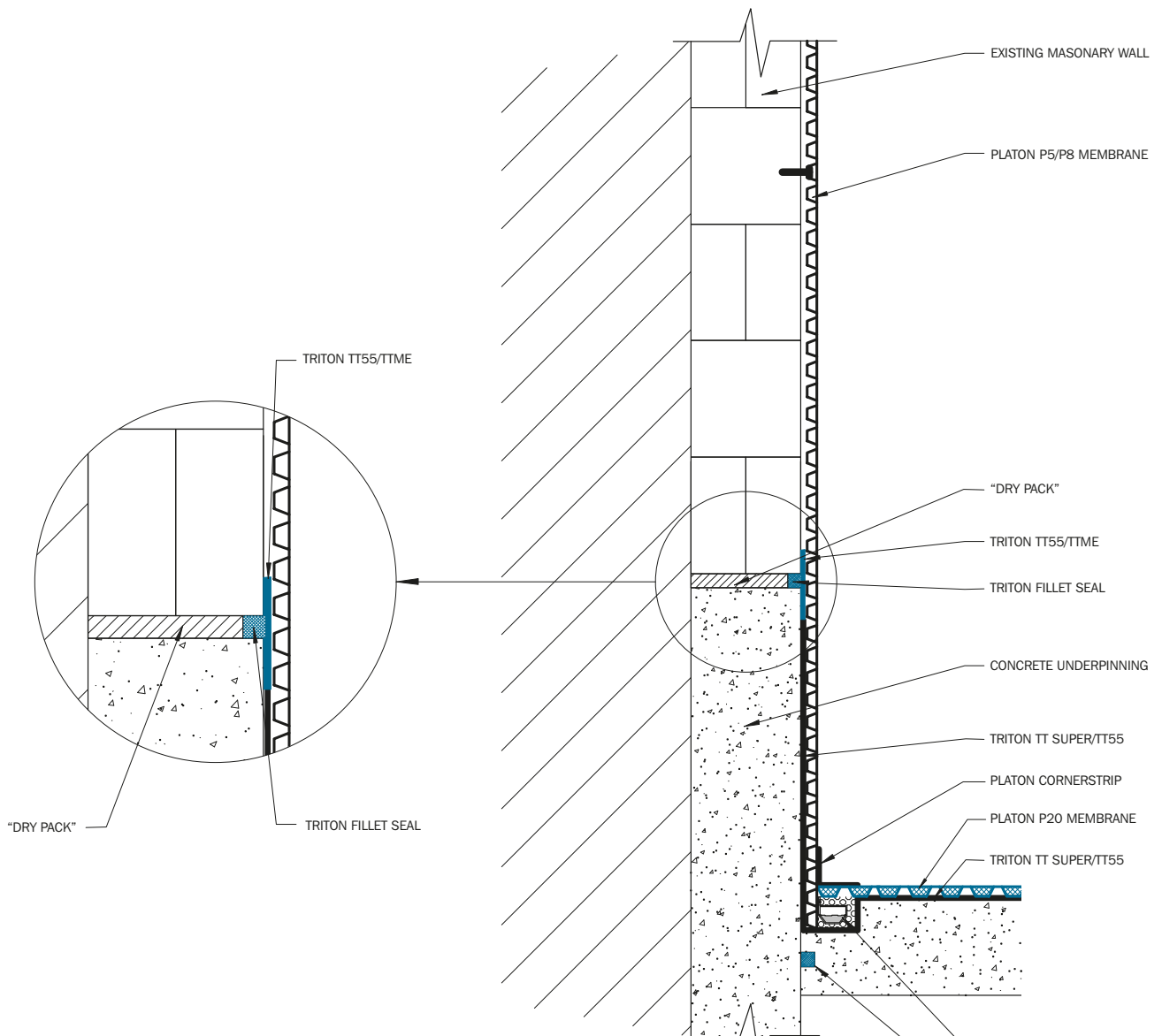

DIAGRAM IP034.1





Aqua Pump and Aqua Channel Service Schedule

Property address:

Job Reference:

Date of Inspection:

Contractor Name:

Aqua Channel	Checked by:	Further action required?
<input type="checkbox"/> Check for Debris		
<input type="checkbox"/> Check Limescale/Silt		
<input type="checkbox"/> Accumulation		
<input type="checkbox"/> Check Jetting Eyes		
<input type="checkbox"/> Flush out Channel		
<input type="checkbox"/> Other		

Aqua Pump (Minimum every 6 months)	Checked by:	Further action required?
<input type="checkbox"/> Clean silt/debris from sump		
<input type="checkbox"/> Clean silt/debris from discharge pipes		
<input type="checkbox"/> Check connections in discharge pipes		
<input type="checkbox"/> Test discharge pipes		
<input type="checkbox"/> Remove & inspect pump(s), wipe clean		
<input type="checkbox"/> Check all pipe & electrical connections		
<input type="checkbox"/> Test float mechanism, clean as required		
<input type="checkbox"/> Check one way valve, clean & test		
<input type="checkbox"/> Reinstate pump into sump & test		
<input type="checkbox"/> Replace pump if/as required		

Battery Back-Up Pump System (Minimum every 6 months)	Checked by:	Further action required?
<input type="checkbox"/> Check all pipe and electrical connections, test		
<input type="checkbox"/> Visually inspect & clean pump, isolate from mains pump and test, inc. pump float switch		
<input type="checkbox"/> Check distilled water levels in battery, top up if necessary		

Continued Overleaf...

High Level Alarm (Minimum every 6 months)	Checked by:	Further action required?
<input type="checkbox"/> Replace 9V battery, check float switch, test to ensure alarm sounds		

Full System Testing On completion of the above steps, flood test whole system	Checked by:	Further action required?
<input type="checkbox"/> Aqua Channel		
<input type="checkbox"/> Pumps & Back Up Pumps		
<input type="checkbox"/> High Level Alarm		

Further Inspections		
Next inspection recommended in: <input type="checkbox"/> 3 months <input type="checkbox"/> 6 months <input type="checkbox"/> 12 months	Contractor's signature:	Client's signature:

Triton Systems

Sales and Technical Support: 01322 318830

www.tritonsystems.co.uk

Cavity Drain Membrane Systems: Pre and Post Installation Checklist

Introduction:

As with all waterproofing systems there is a need for adequate preparation before installation begins, this is also true for Isola Platon cavity drain membrane systems.

It is also important that the installation be tested during installation and at completion prior to handing the project over to the client. This is particularly relevant with cavity drain systems as they will always include sump and pump systems and in many cases drainage channels such as Triton Aqua Channel.

Where pumps, sumps and drainage channels are included within the waterproofing design, a suitable maintenance schedule and contract should be set up with the client. If the client does not wish the contractor to carry out such a maintenance regime, then it is important that they are made fully aware of the need for the pumps and drainage to be maintained.

An example of a typical maintenance schedule can be found in this manual, and it is the minimum required, this should be carried out at **LEAST EVERY SIX MONTHS**.

Below is a check list for pre and post installation of a Platon cavity drain membrane system.

The checklist below is by no means definitive, as this will vary with each project, and is intended as a guide.

Pre Installation:

- Remove all timber, wallpaper and organic materials from walls and floors.
- If timbers suffering from rot, once removed treat masonry with suitable masonry biocide.
- Remove all loose render / plaster from walls along with any other loose debris.
- Remove / lift all electrical and plumbing services.
- Mains boards gas / electric should only be lifted by the supplying company.
- All sharp objects / projections to be removed from walls and floors.
- Floors should be checked for level, ideally at fall to drainage / discharge points, any areas of ponding water floor to be made level.
- If floor is reinforced consult structural engineer prior to cutting any chases for drainage channels and holes for sumps.

Further initial preparation may be required.

Installation Checks:

- Ensure drainage channel runs to a fall towards discharge point.
- Inspection / rodding points are installed to drainage channel, change of direction every 12m.
- Ensure sumps pumps installed in accordance with installation guidelines.
- Flood test basement.
- Make any adjustments / improvements to drainage and pumps if / as indicated by flood test.
- Test to include drainage channels, sumps, pumps (all), alarms etc...

Install Isola Platon membranes to all walls and floors in accordance with this manual.

Post – Installation:

- Complete system to be flood tested
- Any modifications / repairs carried out.
- Re-test!
- Remove any debris from sump chamber.
- Set up maintenance schedule / contract with client, agreeing cost and frequency of maintenance.
- (Advise client of the necessity for ongoing maintenance if they have declined contractor's maintenance contract).

System Maintenance:

The system needs to be fully maintained, a typical schedule can be found in this manual, the frequency of the maintenance should be every SIX MONTHS. If there is a lot of silt / sediment within the ingressing water or if there is new construction e.g. concrete then the frequency of servicing would need to be greater in the early years.

A cavity drain membrane system which is not maintained will be more prone to failure.

If an ongoing maintenance service is not available from the installing contractor, Triton can supply names of specialist servicing companies.

Vertical Service Entry Through Floor Detail

Stage 1

Clean base of service entry then wrap Platon Sealing Rope around base of service entry.

NOTE: If floor conditions are wet then Triton Epoxy Putty can be used.

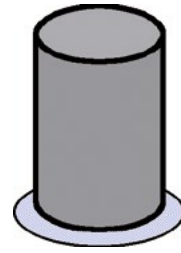

Stage 2

Cut Wall/floor junction material with scissors in segments of 25mm wide up to the centre fold to create a cloak.

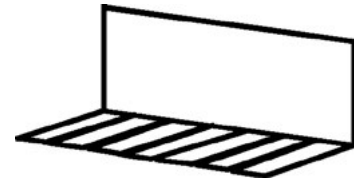

Stage 3

Wrap Wall/Floor junction 'cloak' round entry pipe and press down into Sealing Rope. The overlapping edge is sealed with Sealing Tape.

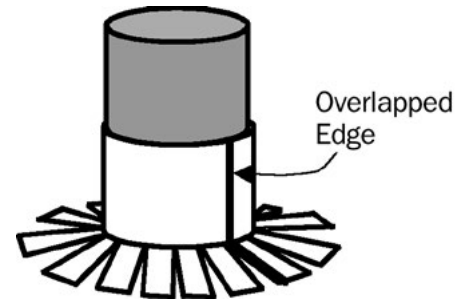

Stage 4

Lay Platon Floor membrane cutting the membrane around the profile of the service entry and wrap another rope seal at the base between the floor membrane and vertical section of Wall/floor junction.

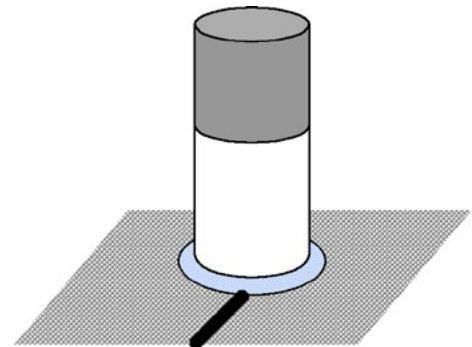

Stage 5

Cut a 300mm (min) square piece of Platon DPC Plain and cut out a hole the size of the service entry. Using scissors cut from one edge of the DPC Plain to the centre hole. Apply Platon Sealing Tape around all edges including the cut section.

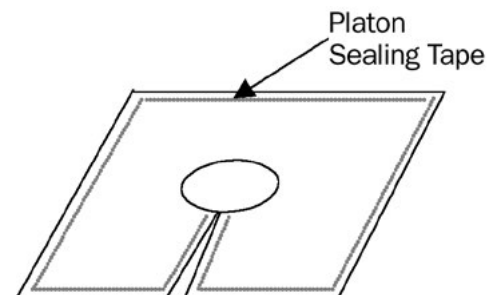

Stage 6

Fit Platon DPC Plain around service entry and seal to floor membrane by pressing down on sealing tape.

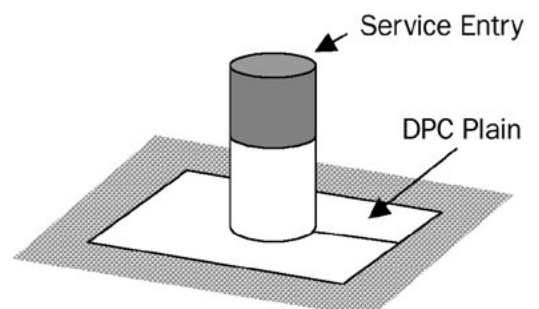

Horizontal Service Entries Through Walls

Platon Flexitett can be used to seal service entries where access is available to slot it over the item. This should be sealed using Sealing Rope around base, double sided tape between the Flexitett and the membrane and then overtaped with Corner Strip.



Product Specifications

Isola Platon Cavity Drain Membranes:

- Platon P8
- Platon P5
- Platon P20
- Platon Plasterbase
- Platon Double Drain

Isola Platon Fixing and Sealing Components:

- Platon Brick Plug
- Platon Plasterbase Plug
- Platon Fixing Cramps
- Platon Sealing Rope
- Platon Sealing Tape
- Platon Plasterbase Overtape
- Platon Wall/Floor Junction
- Wall Fixing Ties

Triton Drainage Products:

- Triton Aqua Pump Pro (Sump, lockable cover, mains powered pump)
- Triton Aqua Pump Pro Plus (Sump, lockable cover, two mains powered pumps)
- Triton Aqua Pump Pro Battery Back Up (Sump, lockable cover, mains powered pump, 24V back up pump, control panel)
- Triton Aqua Pump XL Range (for where greater water ingress is expected – choice of single or dual pump configuration, choice of pump type, choice of auto or manual versions)
- Triton Aqua Channel (peripheral drainage conduit with range of accessories)

System Platon – Product Specification

PLATON P8

Description

Platon P8 membrane is manufactured from high-density polyethylene (HDPE). It is impermeable and resistant to the usual chemicals in the building construction. Studs are formed in a regular pattern on the one face of the product. The studs are spaced at approx. 25 mm centres in both directions. Standard roll length is 20m.

Workability

Platon P8 membrane is tough but pliable and can be bent round corners and projections without risk of breaking, even in very low temperatures. The product can be easily cut with a knife or scissors.

Storage

Rolls of the product should be stored upright when stored over long periods, and referably under cover.

Technical Data

Raw material:	HDPE
Sheet thickness:	Nominal 0.50 mm
Stud height:	Approx. 6.5 mm
Construction height:	Approx. 7 mm
Unit weight:	0.45 kg/m ²
Deformation under long term loading:	Max. 20% (at 50 kN/m ²)
Compressive strength:	150 kN/m ²
Working temperature:	-10° to +60°C
Softening temperature:	+160°C
Linear coefficient of thermal expansion:	0.18 mm/m.°C
Water vapour resistance:	280 m equivalent air layer
Air gap volume:	4.0 l/m ²
Drainage capacity:	Approx. 3.8 l/sm
No. of studs: approx.	1640 per m ²
Life expectancy:	At least 50 years for defined applications
Colour:	Natural

Platon P8 is CE marked in accordance with EN 13967 and EN 13984. A separate declaration gives values for several characteristics.

Chemical Resistance

The product is resistant to all chemicals, to which it can be exposed, in normal building construction.

A small number of aggressive chemicals (e.g. solvents), in large concentrations, can to some extent attack the product during prolonged exposure. For special applications, the supplier should be contacted, with a view to assessing necessary action.

System Platon – Product Specification

PLATON P5 MEMBRANE

Description

The Platon Membrane is manufactured from black or clear “high density” polyethylene (PEH). It is impermeable and resistant to the usual chemicals in the building construction. Square shaped studs are formed in a regular pattern on the one face of the Membrane, and spaced at approx. 25 mm centres. The product is supplied in rolls of 20 m in length.

With the exception of 1 m wide rolls, rolls of the product are supplied with an area without formings along one of the edges of each width. This edge acts as the finish at the top edge on external basement walls, such that the edge is pressed against the wall on backfilling and this prevents fill material from entering the air gap. When the product is used as Separation Board, the edge forms the overlap over the next roll width.

Workability

The Platon Membrane is tough but pliable and can be bent round corners and projections without risk of breaking even in very low temperatures. The Membrane can be easily cut with a knife or scissors.

Storage

Rolls of Platon Membrane should be stored upright when stored over long periods.

Technical Data

Sheet thickness:	nominal 0.50 mm
Stud height (net):	approx. 5 mm
Unit weight:	0.48 kg/m ²
Tensile strength:	at least 10 N/mm ²
Elongation at yield:	at least 10%
Max. compressive strength:	180 kN/m ²
Deformation under long term loading:	max. 25% (under load of 50 kN/m ²)
Working temperature:	-50° to +80°C
Softening temperature:	+125°C
Linear coefficient of thermal expansion:	0.13 mm/m.°C
Life expectancy:	at least 50 years for defined applications.
Thermal resistance:	0.10 m ² .°C/W
Water vapour resistance:	1800 m ² .s.GPa/kg or 350 m equivalent air layer.
Drainage capacity:	max. 2.4 l/sm
Air volume:	3.25 liter/m ²
Colour:	Black or Clear

Chemical Resistance

The Platon Membrane is resistant to all chemicals, to which it can be exposed, in normal building construction.

A small number of aggressive chemicals (e.g. solvents), in large concentrations, can to some extent attack the Platon Membrane during prolonged exposure. If the product is to be applied, for example as cladding to storage tanks for aggressive chemicals, the supplier should be contacted, with a view to assessing necessary action.

System Platon – Product Specification

PLATON P20 MEMBRANE

Description

The Platon P20 Membrane is manufactured from black high-density polyethylene (PEH). It is impermeable and resistant to the usual chemicals in the building construction.

When the product acts as a damp proof membrane, both the product and floor coverings may be installed independent of the moisture content in the underlying concrete construction and with running water not under pressure in the air gap.

Studs are formed in a regular pattern on the one face of the Membrane. The studs are spaced at approx. 60mm centres. The product is supplied in rolls 2.0m x 20m.

Workability

The Platon P20 Membrane is tough but pliable and can be bent round corners and projections without risk of breaking even in very low temperatures. The Membrane can be easily cut with a knife or scissors.

Storage

Sheets of Platon P20 Membrane should be stored flat and rolls of P20 Membrane should be stored on end.

Technical Data

Sheet Thickness:	Nominal 1.00mm
Stud Height (net):	approx. 20mm
Unit Weight:	0.95 kg/m ²
Tensile strength at yield:	at least 10 N/mm ²
Elongation at yield:	at least 15%
Max. Compressive strength:	200 kN/m ²
Deformation under long term load:	max. 10% (load of 50 kN/m ²)
Working Temperature:	-50° to +80°C
Softening Temperature:	+125°C
Linear Coefficient of thermal expansion:	0.13mm/m.°C
Life Expectancy:	at least 50 years for defined applications.
Thermal Resistance:	0.17m ² .°C/W
Water Vapour Resistance:	3500m ² .s.Gpa/KG
Drainage Capacity:	Max. 13 l/sm
Air Gap Volume:	14 litre/m ²
Colour:	Black

Chemical Resistance

The Platon P20 Membrane is resistant to all chemicals to which it can be exposed, in normal building construction. A small number of aggressive chemicals (e.g. solvents) in large concentrations, can to some extent attack the Platon P20 Membrane during prolonged exposure. If the product is to be applied, for example as cladding to storage tanks for aggressive chemicals, the supplier should be contacted, with a view to assessing necessary action.

For normal applications of the Platon P20 Membrane, relevant aggressive chemicals are very volatile, because of their very nature. This means that if they should come in contact with the Platon P20 Membrane, following an accident, they will evaporate or flow away from the construction without permanent damage occurring.

System Platon – Product Specification

PLATON PLASTER BASE

Description

Platon Plaster Base is manufactured from natural high density polyethylene (PEH). It is impermeable and resistant to the usual chemicals in the building construction. The product acts as a damp proof membrane and key for the direct application of cement render or gypsum plaster.

The product and render or plaster may be installed independent of the moisture content in the underlying substrate.

Studs are formed in a regular pattern on the one face of the product, and form undercut cavities creating a key for render and plaster. The studs are spaced at approx. 35 mm centres. The product is supplied in rolls of 20 m in length.

Workability

Platon Plaster Base is tough but pliable and can be bent round corners and projections without risk of breaking even in very low temperatures. The product can be easily cut with a knife or scissors.

Storage

Rolls of Platon Plaster Base should be stored in unbroken packaging and upright, and preferably under cover, when stored over long periods.

Technical Data

Sheet thickness:	nominal 0.50 mm
Stud height(net):	approx. 5 mm
Unit weight:	0.48 kg/m ²
Working temperature:	-50° to +80°C
Softening temperature:	+125°C
Linear coefficient of thermal expansion:	0.13 mm/m.°C
Thermal resistance:	0.10 m ² .°C/W
Water vapour resistance:	1800 m ² .s.GPa/kg or 350 m equivalent air layer.
Air gap volume:	3.2 litre/m ²
Drainage capacity (transmissivity, i=1):	max. 1.84 l/sm
Life expectancy:	at least 50 years for defined applications.
Colour:	Natural

Chemical Resistance

Platon Plaster Base is resistant to all chemicals, to which it can be exposed, in normal building construction.

A small number of aggressive chemicals (e.g. solvents), in large concentrations, can to some extent attack Platon Plaster Base during prolonged exposure. If the product is to be applied, for example as cladding to storage tanks for aggressive chemicals, the supplier should be contacted, with a view to assessing necessary action

System Platon – Product Specification

PLATON DOUBLE DRAIN DRAINAGE & PROTECTION MEMBRANE

Description

Platon Double Drain is a vertical drainage layer for external basement walls and a protection board to primary membranes. It consists of an impermeable studded sheet, manufactured from high-density polyethylene with a polypropylene filter fabric bonded to the top of the surface of the studs.

Channels between the studs form an air gap against the underlying structure. Platon Double Drain forms drainage layers on both sides of the studded core sheet. The filter fabric facing the backfill material ensures the drainage channels are not blocked or obstructed.

Storage

Rolls of Platon Double Drain should be stored upright.

Technical Data

Membrane:	PEH
Filter Fabric:	PP
Stud height:	7 mm
Membrane thickness:	0.5 mm
Weight:	590 g/m ²
Drainage capacity:	max 2.3 l/sm
Resistance to biological attack:	Does not rot or support growth
Chemical resistance:	Resistant to all chemicals in normal building construction
Membrane colour:	Black

PLATON DOUBLE DRAIN 'X' CRAMP

Description

Platon Double Drain 'X' Cramp is manufactured from black polyethylene.

The Double Drain 'X' Cramp fits precisely between four of Platon Double Drain's studs and therefore transmits loading from Double Drain to the nail very effectively. It has a hole size of 3.5 mm diameter. The Double Drain 'X' Cramp has the same height as the net stud height.

For best fit and fixing strength, remove filter fabric from the area of Double Drain to be fixed, place and fix Double Drain 'X' Cramp, then replace filter fabric.

Platon Double Drain 'X' Cramp is resistant to normally occurring chemicals in the building construction.

Pack:	Bag of 60
Delivery unit:	Carton of 9 bags
Article no:	41 30 17
Applications:	With Platon Double Drain on external basement walls.

System Platon – Product Specification

PLATON BRICK PLUG 10x75 mm

Description

Platon Brick Plug 10x75 mm is a plug of polyacetal (POM) with a length of 75mm, and is intended for use in soft brick or stone, which is predrilled a minimum depth of 90 mm from the surface of the Platon Membrane with a drill bit of diameter 10 mm.

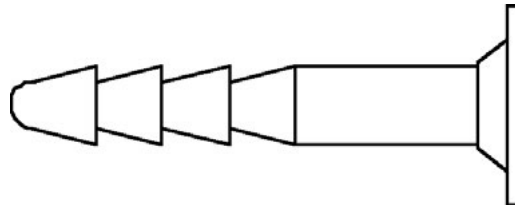

Platon Brick Plug has a head of diameter 30 mm, which is cone shaped like the back face of the Platon Membrane's stud. This gives an excellent transfer of loading from Membrane to the base structure.

There is a 5 mm hole in the shank of the plug for fixing the next layer onto the Platon Membrane, using a screw of diameter 5 to 6 mm, with screwing-in depth of max. 30 mm.

Platon Brick Plug is resistant to normally occurring chemicals in the building construction.

Pack:	Box of 100
Delivery unit:	Carton of 4 boxes
Article no:	413123
Applications:	Sealed System Internal Walls Vaults

PLASTER BASE FIXING PLUG 8x70 mm

Description

The Platon Plaster Base fixing plug is made of Polymer Co Polypropylene with a length of 70mm. It is intended for use in brick, concrete block and concrete, which is predrilled to a minimum depth 85mm from the surface of the Platon Plaster base membrane with an 8mm-diameter drill bit.

The head of the Plaster base plug has a diameter of 35mm with an embossed surface to provide a mechanical key for subsequent plaster/render. The Plaster Base fixing plug is resistant to normally occurring chemicals in the building construction.

Technical Data

Colour:	opaque
Thickness:	8 mm
Length:	70mm
Working Temperature:	-30°C to +90°C
Life expectancy:	at least 50 years
Chemical resistance:	as for Platon Membrane

NOTE: The fixing is not suitable for direct, long-term exposure to UV radiation

PLATON MEMBRANE SEALING TAPE & ROPE

Key Features

Based on a blend of butyl and other rubbers, this versatile strip sealant has good tack and adhesion to most common surfaces whilst having good movement accommodation.

Standard colour – blue

Performance

The following performance data assumes good joint design. For non-standard situations refer to Technical Services Department.

Movement Accommodation:	±15% when used in lap and cover joints.
Adhesion:	has good surface tack and adheres well to most building materials.
Shear Strength:	14N.
Compression (force required to compress by 20%):	200N
UV Light Resistance:	Very Good.
Chemical Resistance:	Good to diluted acids and alkalis. Not recommended for extreme chemical exposure.
Service Temperature Range:	–40°C to +110°C.
Expected Life:	The Sealing Tape & Rope is a durable material and can have a life in excess of 20 years depending on the service temperature and joint design.
Shelf Life:	1 year.
Elongation Of Break:	220%.

Application

Surface Preparation:	All surfaces should be clean, dry and free from frost, grease and loose material.
Application Details:	Should be applied directly from the reel onto one surface pressing sufficiently to ensure adequate initial adhesion. Remove backing paper and apply other surface onto Sealing Tape and Rope pushing firmly to ensure good contact with full area of strip along the length of the joint.
Application Temperature Range:	+5°C to +30°C.
Priming:	Primers are not required for good adhesion to most surfaces.

Packaging

Single strand reels on silicone release paper. Metres per reel and reels per carton depends on the thickness and width respectively.

Tolerance:	Thickness:	± 10%
	Width:	up to 15mm ± 1mm 15-25mm ± 1.5mm over 26mm ± 2mm

Bead sections available in 10mm diameter.

Tolerance:	Thickness:	nominal to nominal less 12%
	Width:	nominal to nominal plus 12%

Health & Safety

There are no known health hazards associated with Platon Sealing Tape/Rope in normal use. Wash hands immediately after use.

PLATON PLASTER BASE FLEECEBAND OVERTAPE

Key Features

Based on a blend of butyl and other rubbers, this non woven fabric-backed versatile strip sealant has good tack and adhesion to most common surfaces whilst having good movement accommodation.

Standard colour – black with grey fleece

Performance

The following performance data assumes good joint design. For non-standard situations refer to Technical Services Department.

Movement Accommodation:	±15% when used in lap and cover joints.
Adhesion:	has good surface tack and adheres well to PVC, many metals and plastic materials.
Shear Strength:	16.2N.
Compression To Seal:	Positive Pressure
Force To Compress By 20%:	200N
UV Light Resistance:	Excellent.
Chemical Resistance:	Good to diluted acids and alkalis. Not recommended for extreme chemical exposure.
Service Temperature Range:	-40°C to +110°C.
Expected Life:	The Fleeceband overtape is a durable material and can have a life in excess of 20 years depending on the service temperature and joint design.
Shelf Life:	1 year.
Elongation Of Break:	220%.

Application

Surface Preparation:	All surfaces should be clean, dry and free from frost, grease and loose material.
Application Details:	Remove backing paper and apply directly from the reel onto membrane surface pressing firmly to ensure adequate adhesion along the length of the joint.
Application Temperature Range:	+5°C to +45°C.
Priming:	Primers are not required for good adhesion to most surfaces.

Packaging

Single strand reels on silicone release paper. Metres per reel and reels per carton depends on the thickness and width respectively.

Tolerance:	Thickness:	± 10%
	Width:	± 2mm

Health & Safety

There are no known health hazards associated with P5 Sealing Tape/Rope in normal use. Wash hands immediately after use.

System Platon – Product Specification

PLATON WALL/FLOOR JUNCTION FOR SEALED SYSTEM

Description

Platon Wall/Floor Junction is manufactured from black High Density Polyethylene (PEH). It is impermeable and used to provide a continuous seal between two adjacent sheets of Platon Membrane with Platon Sealing Tape around external (or internal) corners in walls or similar projections. Installation is carried out simply by folding the product along the preformed crease, and placing with the flat face towards the Platon Membrane on each adjacent wall surface.

Wall/Floor Junction is supplied in lengths of 2 m with a preformed crease for the fold line along the centre line. 10 lengths rolled up together.

Workability

Platon Wall/Floor Junction is easily cut with a knife or scissors.

Storage

Over long periods Platon Wall/Floor Junction should be stored indoors, standing as a roll in unopened packs, and not exposed to direct sunlight.

Technical Data

Colour:	black
Thickness:	0.6 mm
Width:	300 mm
Weight:	approx. 0.80 g/m
Working Temperature:	-50°C to +80°C
Linear coefficient of thermal expansion:	0.13 mm/m°C
Life expectancy:	at least 50 years
Water vapour resistance:	1800 m ² .s.GPa/kg
Chemical resistance:	as for Platon Membrane
Sizes/Article no.	Length of 1.30 m 414101
Delivery unit	Roll of 10 lengths
Applications:	Sealed System

System Platon – Product Specification

PLATON CORNER STRIP

Key Features

Based on a blend of butyl and other rubbers, this versatile strip sealant has excellent high tack adhesion and will adhere to most common surfaces whilst having good movement accommodation.

Standard colour – white adhesive base with aluminium lead look top surface

Performance

The following performance data assumes good joint design. For non-standard situations refer to Technical Services Department.

Movement Accommodation:	±5% when used in lap and cover joints.
Adhesion:	has excellent surface tack and adheres well to PVC, many metals and plastic surfaces.
Shear Strength:	14N.
Compression To Seal:	Positive Pressure
UV Light Resistance:	excellent.
Chemical Resistance:	Good to diluted acids and alkalis. Not recommended for extreme chemical exposure.
Service Temperature Range:	-40°C to +90°C.
Expected Life:	The Sealing Tape & Rope is a durable material and can have a life in excess of 15 years depending on the service temperature and joint design.
Shelf Life:	1 year.
Elongation Of Break:	220%.

Application

Surface Preparation:	All surfaces should be clean, dry and free from frost, grease and loose Material.
Application Details:	Remove backing paper and apply directly from the reel onto membrane surface pressing firmly to ensure adequate adhesion along the length of the joint.
Application Temperature Range:	+2°C to +30°C.
Priming:	Primers are not required for good adhesion to most surfaces.

Packaging

Single strand reels on silicone release paper. Metres per reel and reels per carton depends on the thickness and width respectively.

Health & Safety

There are no known health hazards associated with Platon Corner Strip in normal use.
Wash hands immediately after use.



Triton Systems

Units 3 – 5 Crayford Commercial Centre, Greyhound Way, Crayford, Kent DA1 4HF
Tel: 01322 318830 Fax: 01322 524017 Email: info@tritonsystems.co.uk

Triton Chemical Manufacturing Co Ltd trading as Triton Systems

www.tritonsystems.co.uk