

Installation Instructions

NEWTON SYSTEM 800

Damp Proofing & Plaster Base Meshed Membranes

Rev 2.0 - 15 February 2016

INTRODUCTION

[Newton 803 Newtonite](#) and [Newton 805 Newlath](#) are damp proofing membranes for use as a plaster or render base for walls that are above the external ground level. Both products are suitable for internal use, however they are not suitable for use as a waterproofing membrane in basements or to earth retaining walls. If the membrane is not to be used as a render base, and where a block wall or dry-lining frame will be used, use [Newton 803](#). Newton 803 should also be used if insulation is required to the wall build, with an independently supported wall frame.

Newton 803 Newtonite and 805 Newlath are not suitable for use with laminated or insulated plasterboard, as this requires mechanical fixings which will breach the membrane. If the requirement is for a cellar, basement or earth retaining wall, [Newton System 500](#) should be used instead.

PREPARATION

Clean the substrate to remove all loose debris and organic matter. Plaster should be removed as it can soften over time and weaken the fix of the membrane to the wall. If the wall render is in good condition it will not have to be removed, however if it is damaged, local repairs may be required. Loose or crumbling render should be removed, and if it is in very poor condition, all of it may need to be removed in order to obtain as flat a surface as possible.

If the wall is undulating, better results are produced if the wall surface is dubbed-out flat with sand & cement prior to installation of the membrane, rather than dubbing out over the top of the membrane. A flat and uniform substrate means that the plaster or render above the membrane will also be uniform, and therefore less likely to crack as a result of differential thicknesses.

If evidence of bacterial growth can be seen, use a fungicidal product prior to the fitting of the membrane. If any evidence of wet rot or dry rot is seen, have it dealt with by a qualified remedial specialist.

If a new slab is to be laid as part of the works, it is preferable to fit the membrane prior to the laying of the floor slab, with the floor DPM extending upwards in front of the Newton 803 Newtonite or 805 Newlath, ready for the concrete pour.

CUTTING TO SIZE

Newton 803 Newtonite & 805 Newlath can be cut with a sharp utility knife, scissors, or shears. Decide whether the membrane is to be fitted horizontally or vertically, then cut the membrane to size. Ideally, the membrane should be continued up into ceiling voids and down past the slab to the oversite. If this is not possible, cut the membrane so that it finishes tightly to the soffit and floor finish. A gap is not required at the soffit or floor, indeed the system works more efficiently when the system is not ventilated as this impedes the natural vapour drive that still continues through the membrane, from inside the property to outside.

FIXING TO THE WALL

Newton 803 Newtonite & 805 Newlath are fitted with the studs facing the wall and the meshed surface facing inwards. Fix the membrane to the wall with the [Newton 800 Mesh Plug](#), which are applicable to all substrates except plywood or timber, when a galvanised clout nail should be used, or to slightly friable mortar substrate, when the [Newton 800 Cob Plug](#) should be used.

Fit the membrane as level as possible - best results are achieved when a long builders level or a rotating laser level is used. Care must be taken to ensure that the membrane is pulled tight and square while fixing as this will avoid sagging or bulging which can cause problems when plastering or rendering. Using either a 7mm or 8mm drill bit (depending on the substrate - a smaller-diameter drill bit can be used on softer substrate to ensure a tight fit for the plug), drill through the membrane into the wall to a depth of at least 50mm. Apply a bead of mastic to the surface of the membrane around the hole so that when the plug is hammered home, the mastic will create a seal between the head of the plug and the face of the membrane, and so prevent migration of dampness and salts from the substrate to the wall finish.

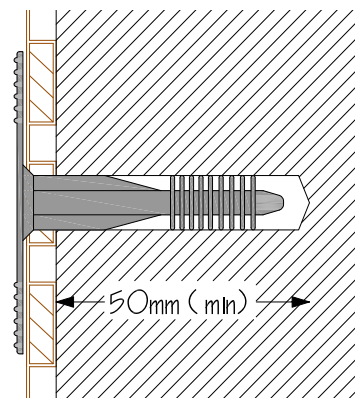

NEWTON SYSTEM 800

Damp Proofing & Plaster Base Meshed Membranes

Use a small number of fixings to initially fit the membrane to the wall as level as possible. Once the section of membrane is in place then further fixings can be added and hammered home using a wide headed hammer such as a lump hammer or mallet. Fixing should not take place above 30°C or below -5°C.

Fixing centres must not be greater than 250mm, however on curved or uneven surfaces, closer fixings should be used. Closer fixings are also recommended on exposed areas in order to restrain possible thermal movement. Fit the membrane 300mm to return walls to isolate wall finishes from dampness transmitting from the main wall being treated. Both Newton 803 Newtonite and 805 Newlath can also be taken into reveals.

JOINTING

Joints may be made horizontally or vertically. Position fixings close to the edge of all joints to reduce the risk of shrinkage cracks. Joints are created by butt jointing the two edges together and then oversealing the joints with [Newton Mesh Tape](#). Newton 803 Newtonite and 805 Newlath can usually be taken round corners, however on particularly difficult corners, cut the membrane before butt jointing and sealing it as just described. Newton Mesh Tape should be firmly pressed into the mesh of the membrane in order to facilitate the joint, and in cold and damp conditions a heat gun may also be required to gently evaporate surface moisture and then to assist in pressing the Newton Mesh Tape into the mesh of the membrane.

SEALING AROUND PROTRUSIONS

Where the membrane has to be cut around pipes or other protrusions, carefully cut the membrane around the protrusion then seal the gap with [Newton 801 Mastic](#) in order to ensure that there is no bridging between the damp substrate and the new internal finish.

PUNCTURING THE MEMBRANE

If the finished wall is punctured when holes are drilled to fix brackets, etc., Newton 801 Mastic should be inserted before fixing bolts are inserted to ensure no bridging from the damp substrate occurs.

FINISHING PROFILE

It is recommended that renders and plasters are raised from the floor by 20-25mm to prevent bridging from the floor. [Newton 800 Profile](#), available in 2 metre lengths, should be fitted to the bottom of the membrane as a plaster stop, guaranteeing that the plaster/render will stop short of the floor. Newton 800 Profile must be fixed at the same time as the membrane and therefore before the plaster or render is applied, however it is not recommended where the run of wall is uneven or when the membrane is extended down past the slab. Once the finish has been applied and has dried, the 20-25mm gap to the bottom of the plaster/render should be covered by a wooden skirting.

FINISH (GENERAL)

Newton 803 Newtonite and Newton 805 Newlath are both suitable for use internally. The wall finish can be plaster, render, hydraulic lime or plasterboard bonded to the membrane with a propriety adhesive compound. Whilst any cement rendering is prone to cracking, careful application can reduce or avoid this. Problems frequently occur when the scratch coat has not been allowed to fully cure prior to the float coat being applied, however the most common problem that we see is where the render has not been allowed to fully cure due to accelerated drying. It is extremely important that the render is slowly cured for a period of at least 7-10 days. The render gets its strength from the chemical processes that take place between the cement content and the added water, and therefore needs the correct amount of water to be available to it during the whole of the curing period. If the render dries too quickly due to exposure to sunlight, wind or even dehumidification, the cement will not be able to react with the water, producing a weak render that will be more prone to cracking. The render should therefore be dampened regularly during the curing process. Any hairline cracking can be made good with fine fillers or alternatively a high-build masonry paint can be applied.

DO NOT APPLY DECORATIONS UNTIL PLASTERS OR RENDERS ARE THOROUGHLY DRY.

PLASTERING

The recommended plaster for Newton 803 Newtonite and 805 Newlath is Tarmac Whitewall One Coat. Please note that we do not recommend that this product is used in one single coat to Newton Mesh membranes. The application of the plaster should be in two coats: a 6mm scratch coat, and a 6mm second or float coat. If a finish coat is required this should be of 3mm. Tarmac Whitewall should be applied in accordance with good plastering practice, as described in BS 8481:2006 and BS EN 13914-2:2005. Always allow 24 hours drying time between coats of plaster. For a high impact resistant finish, use Whitewall High Impact Backing Plaster.

NOTE: Tarmac Whitewall and Tarmac Whitewall High Impact Backing Plaster are not suitable for areas of high humidity and wet areas such as swimming pool surrounds.

NEWTON SYSTEM 800

Damp Proofing & Plaster Base Meshed Membranes

RENDERING

Render with a mix of sand, cement and lime should be applied in two coats using the procedures defined within BS EN 13914-1:2005 to a total thickness of 14mm. A 3mm skim coat of finishing plaster can be added once the render is fully cured. The scratch coat should be a mix of 1 part lime: 1 part cement: and 5 parts clean well-graded sharp sand. The second or float coat should be a mix of 1 part lime: 1 part cement: and 6 parts clean well-graded sharp sand. The scratch coat should be 7mm and the second or float coat should be 7mm.

To lessen incidents of cracking, it is best to mix the lime and sand a day or more before use. Cement can then be added at the time of rendering. The work should be of two coats of render and if required, a third coat of finishing plaster. The purpose of the 7mm scratch coat is to stiffen up the lath and to provide rough and absorbent, backing for subsequent coats.

Work this scratch coat well into the mesh. Each 7mm coat of render should be allowed to dry for a period of not less than seven, preferably ten days, longer if possible. Cracking may occur if shorter time is allowed between coats. It is important that the render coats are allowed to cure correctly over the 7 to 10 day period with the render dampened as required. If the scratch coat has not fully cured, slumping of the render can result. Before applying the second or float coat, carefully drill or scratch out a small section into an area behind the mesh, within the membrane stud, to confirm that it is fully cured. The surface will cure quite quickly but the area behind the mesh must be fully cured also. In warm periods the render should be protected from excessive drying out by covering with damp hessian sheets and plastic sheeting over it. Dampen down the scratch coat before application of the float coat. A smooth finish is not recommended.

Expansion joints should be trowelled in through the render to the membrane. These joints must be filled with a suitable flexible polymer-based sealant. Expanded metal angle beads and stop beads can be fixed where appropriate using dabs of the same material mixed as for the scratch coat.

HYDRAULIC LIME

NHL (Natural Hydraulic Lime) 3.5 should be used to a combined depth of 20mm with a 10mm scratch coat and a 10mm second or float coat. The mix ratio is 2.5 parts sand to 1 part NHL 3.5 mixed as per manufacturers instructions. The 10mm scratch coat is pushed firmly into the membrane mesh. Check the application the day after and rub out any cracks. The surface should be thoroughly scratched without breaking the surface of the mesh.

The scratch coat has to be left for a minimum of 7 days to set. It should be protected from draughts and extremes of temperature.

Before applying the second or float coat, carefully drill or scratch out a small section into an area behind the mesh, within the membrane stud, to confirm that it is set and reasonably hard. The surface will cure quite quickly but the area behind the mesh will take longer to set. The second coat is the float coat and is applied then ruled off to flatten the wall surface. The mix ratio is 2.5 parts sand to 1 part NHL 3.5 mixed as per manufacturers instructions. The scratch coat has to be dampened down before application of the float coat. The work has to be protected and tended as per the scratch coat. The second coat is floated or trowelled so a finish coat or a further coat can be applied.

PLASTERBOARD ON DABS

Plaster board panels can be fixed to Newton 803 Newtonite and 805 Newlath by the dot and dab method, giving a dry surface ready for immediate decoration. 'Dabs' should be applied to the heads of the Newton 800 Mesh Plugs, board edges and membrane to cover 50% of the membrane.

NOTE: We do not recommend that laminated or insulated plasterboard is dot and dabbed to Newton meshed membranes.

Laminated boards have to be fixed to the wall with a mechanical fixing at each side of the board, just above half way up, so that the board does not come apart during a fire. This is a requirement of UK building code. It is not possible to mechanically fix through the laminated board without puncturing the membrane. If insulation is required to the wall build, use Newton 803, which is not meshed, with an independently supported wall frame.

DO NOT APPLY DECORATIONS UNTIL PLASTERS OR RENDERS ARE THOROUGHLY DRY.

NOTE: Although Newton 803 Newtonite and 805 Newlath pose no health hazards, usual protective clothing and goggles should be worn in accordance with current health and safety regulations.

Newton 803 Newtonite, 805 Newlath, 800 Profile, 801 Mastic, Mesh Tape, Mesh Plugs and Cob Plugs are all available directly from Newton Waterproofing Systems.

Technical staff will be pleased to give help and advice on the most effective use of the product.

Newton Waterproofing Systems reserve the right to update product literature at any time. Please always refer to our [website](#) for the latest versions.