

Installation Manual
NEWTON CDM
Cavity Drain Waterproofing System

Rev 9.0 - 05 December 2017



Section	Title	Page
1.	Introduction of Newton CDM	3
2.	Design Principles	6
3.	Preparation	8
4.	Wall Application Newton 508 & 508R	9
5.	Wall Application 503 Mesh & 508 Mesh	11
6.	Floor Application Newton 508R & 508 eco Floor	13
7.	Floor Application Newton 520 eco	14
8.	Vault Application	15
9.	Sealing Instructions	17
10.	Ventilation	20
11.	Repairs	23
12.	Maintenance	24
13.	Product Guide	25
14.	Appendices – Technical Drawings (14 No.)	26



SECTION 1. INTRODUCTION OF NEWTON CDM

1.1 INTRODUCTION

Newton Waterproofing Systems was established in 1848 as John Newton & Co. Ltd. and has been involved in the remedial damp proofing industry since 1937 with the introduction of the original Newtonite Lath ventilated damp proofing membrane. With our unique long standing experience in this industry we have evolved our products and technical support to the present high standards we now offer.

Newton CDM is a Type C waterproofing system that includes BBA Certified membranes, drainage channels, pumping systems and pumping ancillaries specifically designed for waterproofing earth retaining structures against water from the ground.

The system works by creating a depressurisation space using the studded Newton membrane on the internal surface and drainage channels at the known and/or designed points of weakness in the structure. The system includes a range of tapes, fixing plugs and sealants. Newton CDM also provides protection when used in earth retaining scenarios for those substrates contaminated by carbon deposits, salts, fertilizers etc., and can also offer protection in high radon and methane gas locations.

The Newton CDM system does not seek to hold back water pressure. Water ingress is controlled and managed by the depressurisation spaces created by the system. The membranes do more than provide a dry inner skin to separate the wet substrate and dry interior, with the studs acting more like stilts to allow for this natural movement of water rather than a pressure-resisting barrier. The draining of the water away from the system is therefore vitally important, and if designed correctly is the safest method of waterproofing available.

1.2 PRODUCTS WITHIN RANGE

The Newton CDM system comprises a range of specifically designed complementary products. The products that make the waterproofing system are listed below, together with a brief explanation of each product use:

Newton 508R

High Density Polyethylene (HDPE) Cavity Drain Membrane with 8mm deep conical studs for lining walls, soffits and floors. Newton 508 is certified for use as a gas barrier and is the membrane to be used to both walls and floors with the Newton PAC Gas System. Rolls are 20m long and either 2.07m or 2.4m wide including the 70mm flat jointing flange.

Newton 508

Lighter weight version of Newton 508R that is suitable for walls only. It is not suitable for use with gas protection systems or for use as the floor membrane. Rolls are 20m long and 2.4m wide including the 70mm flat jointing flange.

Newton 508 eco Floor

Made from fully recycled HDPE, Newton 508 eco Floor is the strongest Newton membrane and so is ideally suited as a flooring membrane. It has a higher studs per metre ratio than any other Newton membrane making it the ideal membrane to be used above the Newton Fibran XPS 500-C insulated drainage space. Rolls are 20m long and 2.5m wide including the 70mm flat jointing flange.

Newton 508 Mesh

High Density Polyethylene (HDPE) Cavity Drain Membrane with 8mm deep conical studs for walls and soffits. The membrane has nylon mesh thermally welded to the face of the membrane to act as a key for plasters, renders and as a base for dot-&-dab plasterboard. Rolls are 20m long and 2.0m wide including the 70mm flat jointing flange.

Newton 503

High Density Polyethylene (HDPE) Membrane with 3mm deep square pattern studs for floors. Newton 503 is ideal floor membrane to a Newton Waterproofing System where 20mm or even 8mm studs cause problems with floor height or where a thinner membrane than 508 is required to the walls. Rolls are 20m long and 2.0m wide.

Newton 520 eco

A fully recycled High Density Polyethylene (HDPE) Cavity Drain Membrane with 20mm deep conical studs for floors. Newton 520 is used where it is expected that water may ingress the structure through slab defects and a greater drainage performance is required. Newton 520 eco is black and comes in 20m long x 2.00m wide rolls including the 70mm flat jointing flange.

Newton Condensation Strip

Forms an 8mm gap between the Basedrain perimeter drainage channel and wall membrane so that if condensation should form, it will be collected by the Basedrain and not pool on the floor, damaging finishes.

Newton 906 Lime Inhibitor

A surface applied treatment prevents the leaching of free lime from out of the concrete.

Waterseal Rope

Butyl rope in a 10mm bead used for jointing membranes when a flange seal is not possible. Rolls are 4.75m long in black.

Waterseal Tape

Butyl tape used for jointing membranes along the flange. Rolls are 22.5m x 2mm x 30mm wide in black.

MultiPlug

The Newton MultiPlug has been developed to provide an improved fixing product over the Nuseal Plugs. The MultiPlug has been engineered to give a better fix in questionable substrate, and have the added benefit of having a rubber sealing grommet supplied with the plug. If the fix is not as good as hoped, a pin (supplied in bags of 100 at extra cost) is inserted into the plug that expands its outer circumference by nearly 2mm to tighten the plug into the substrate. The MultiPlug is pre-drilled to accept a size 10 (5mm) self-tapping screw for the fixing of battens or other dry-lining systems. 100 plugs per bag coloured blue. Requires a 10mm drilled hole for insertion. For vaulted ceilings use either MultiPlug replacing the rubber sealing grommet with a bead of Newton Waterseal Rope or the Nuseal Plug with a bead of Waterseal Rope.

Nuseal Plug

The Newton Nuseal Plug is used with Newton Waterseal Rope to provide a watertight seal between the plug and the membrane and is the plug used for fixing our membranes to vaulted soffits. The Nuseal Plug is pre-drilled to accept a size 12 (6mm) self-tapping screw for the fixing of battens or other dry-lining systems. 100 plugs per bag coloured red. Requires a 11mm drilled hole for insertion.

Newton Overtape

Black PVC backed one-sided tape used for connecting floor membranes to the Basedrain up-stand, Floor membranes to wall membranes, sealing abutting joints to Newton 503 and for repairs and reveal details. Rolls are 20m long x 150mm or 100mm wide.

Newton Mesh Tape

One-sided fabric tape used for over taping joints to Newton 503 Mesh or Newton 508 Mesh which have already sealed with Waterseal Rope or Waterseal Tape as a surface key for plastering or rendering. Rolls are 10m long x 100mm wide.

Newton Basedrain & Floordrain

White PVC drainage conduit designed to drain System 500 at the wall/floor junction and at construction joints to the floor. Has 18mm holes every 100mm along its length to receive water pressure at the vulnerable junction of wall and floor and at construction joints within the floor. Has fittings to allow for connection to the Titan-Pro sump chambers and to 63mm O/D pipe for further connection to 110mm drainage pipe for where safe gravity removal of water is possible, as well as variable height inspection ports, T Pieces and 90 degree swept corners. Six 2m lengths per pack.

Fibran XPS 500-C - Insulated Spacer

Sheets of XPS insulation form a 50 mm insulated spacer adjacent to the Basedrain and Floordrain drainage channels within the Newton CDM waterproofing system. The insulation boards are rated at 500 kPa and feature specifically designed slots to the underside of the boards, that in combination with the perimeter and spine drainage channels of Newton System 500 form a fully drained supporting spacer below the floor drainage membrane.

Newton 809-DPC

High-load capable, BBA certified physical damp-proof course which is used within the Newton CDM system to ensure continuity between the wall and floor membranes through an internal block wall, or block spine walls built from a kicker or engineering brick.

Clean (Ground) Water Pump Systems

A selection of pumping systems based upon the Titan-Pro pumping system are available from 250W to 750W motors, heads from 7.2m to 14m and flow rates of 180 litres per minute to 410 litres per minute. The Newton Inverter/Charger units will allow the pumps to be operational even in the event of power failure, with our top of the range battery back-up system with generator offering weeks of power outage protection. Our Control Panels offer sophisticated switching and control of the manual versions of the pumps, and when coupled with the Newton Dialer have the ability to send text or voice messages to the client to warn of pump problems if they occur. The Titan-Pro chamber is supplied with a recessed lockable lid that is able to receive a range of floor finishes including screed, tile, carpet, linoleum, and chipboard.

Sewage (Dirty) Water Pump Systems

A full range of packaged sewage systems and sewage lifting stations are also available. We strongly recommend that clean ground water and sewage/dirty water should be kept separate and not collected in the same chamber.

1.3 BS 8102:2009 - DRAINED PROTECTION

British Standard BS 8102:2009 is the Code of Practice for the Protection of Below Ground Structures Against Water from the Ground.

All waterproofing of structures below the ground, or those partially earth retaining, should be designed to comply with BS 8102:2009. Amongst other recommendations, BS 8102:2009 states that you should assume a head of water pressure to the full depth of the basement unless extensive ground water analysis has been undertaken. Even then, the designer should take into account the possibility of high ground water levels due to climate change, burst water mains etc. All waterproofing systems should be designed to deal with expected heads of water pressure.

Note: Newton CDM is a drained cavity system. To comply with BS 8102:2009, adequate drainage and water removal must be included within the design to remove water from behind the system. The Newton CDM system will not hold back water pressure.

1.4 FINISHING

A wide range of finishes can be employed to walls and floors. These provide protection for the membrane, and create a decorative finish.

1.5 TYPICAL FLOOR FINISHES - See technical drawings (JN5010)

1. Screeds to either manufacturers recommendations or relevant British Standard
2. Wood-based sheets (flooring grade with T&G joints)
3. Timber boarding on timber battens
4. Floor tiles or flooring slabs
5. Sports floors, suspended floors etc. (not shown in JN5010)
6. All the above can be laid with or without insulation as specified

1.6 TYPICAL WALL FINISHES

1. Independent metal or timber frame system using Newton 508. See technical drawing JN5011
2. Fixed Metal Frame system using Newton 508. See technical drawing JN5014
3. Dry lining with battens using Newton 508. See technical drawing JN5015
4. Plastering direct using Newton 508 Mesh. See technical drawing JN5012
5. Dry lining with dabs using Newton 508 Mesh. See technical drawing JN5016
6. Examples 1. 2. and 3. can be installed with or without insulation as specified

SECTION 2. DESIGN PRINCIPLES

The design of the Newton CDM cavity drainage waterproofing system is specific to the type of structure to be waterproofed. An understanding of the structure, specifically how and where it may leak, is very important. Whether the waterproofing system is to a new build structure or to an existing structure also dictates the design principles.

Drained waterproofing is often interpreted as being a holistic method of waterproofing whereby the water is allowed to come in through the structure and is dealt with using drainage systems that will remove the water more quickly than it enters. In general terms the statement is correct, but unfortunately we have to be more specific than this. For example, it would be pointless to design a new structure that would allow large volumes of water to enter if the structure is sited within ground that has a propensity for high and far-reaching water tables. It would be impossible to calculate how much water would or could enter the structure and so it would be difficult to design a waterproofing system to deal with this unknown amount of ingressing water. Therefore we consider the following rules of thumb to be applicable:

2.1 EXISTING STRUCTURES

- An existing structure may or may not have been designed to withstand heads of water pressure as required by BS 8102:2009
- An existing structure may or may not have a correctly working form of external drainage
- It is difficult to ascertain whether the ground surrounding the structure is free draining or not
- It is difficult or often impossible to ascertain whether the design engineer of the existing structure was aware of the potential for water ingress caused by high groundwater levels. Victorian and Georgian engineers seemed to have a good understanding in this regard, and it is quite rare to see a badly flooded Victorian or Georgian structure. Many Victorian and Georgian structures were built with some form of drainage system below or around the structure
- It is difficult or often impossible to expose the outside of the structure down to slab/raft/footing level to either investigate the cause of failure or to apply remedial measures

Waterproofing of existing structures falls into two categories:

1. Those structures that have been built for some considerable time, where there is no indication as to the design principles used during construction. These structures are in the main built with brick walls and in-fill concrete slabs or floors of other materials. These structures tend not to have major water ingress problems, although this cannot be guaranteed. However, this type structure offers very little resistance to water pressure, and will leak freely at the wall/floor junction if even a very small head of water pressure comes to bear. It is very rare for water to ingress at any other point other than the junction between wall and floor, as this is by far the weakest point within this relatively weak structure. Typically, waterproofing a structure such as this will involve the siting of Newton Basedrain at the junction between all walls and floors, as well as Newton 503, 508, 508R or 508 Mesh to the walls, and either Newton 508R, 508 *eco* Floor, Newton 503, or Newton 520 *eco* to the floor. Water should only ingress through the floor if the floor is in particularly poor order and is not offering a resistance to the water pressure that is creating the ingress at the open gap between the wall and floor. In many cases a new slab is laid, and if laid in accordance to the relevant British Standards, this new slab will offer a much greater resistance than the original floor, thus guaranteeing that water will ingress at this weak junction between wall and floor. See technical drawing JN5017
2. Structures that have been built more recently and that have flooded within a few weeks/months/years of construction, where the design principles are still available, and often the designers themselves are available to offer an insight into their design principles. These structures are mainly built with more modern construction products such as reinforced concrete rafts, and reinforced shuttered concrete or concrete block walls with reinforced concrete filling the cavity. Structures built more recently should have been built in accordance with modern building regulations and the relevant British Standards. Because these structures are so strong, and the concrete is placed to a recent British Standard, water generally enters this type structure at joints within the concrete, for example at kicker joints; movement joints; and construction joints. If the flow of water at the joints can be seen, it is good practice to try and stop or at least slow down the flow water using Newton 313 WaterPlug, concrete repair or resin injection products. Once the flow of water has been reduced or stopped, the Newton CDM system can be applied to the structure to deal with any leakage. Newton 503 or 508 or 508R should be applied to all vertical surfaces, with Newton Basedrain installed at the wall floor junction. Newton Floordrain should be laid at all joints within the structure in case of leakage. Newton 508R, Newton 503 *eco* Floor, Newton 503, Newton 520 *eco* should be used as the flooring membrane. See technical drawings JN5018 & JN5019

2.2 NEW BUILD STRUCTURES

The waterproofing of new build structures is very similar to the waterproofing of existing concrete structures as mentioned in section 2. above. The basic principle of waterproofing existing structures is to build the structure so that it is as water tight as is required for the intended end use of the structure, with the intention in most cases that no water should enter the structure. The structure should be strong enough so that it can resist the stresses of withstanding heads of water pressure as required by BS 8102:2009, and the design should ensure the prevention of differential settlement, the control of cracking and provision of a dense impervious concrete structure. Hairline cracks should be made good, and any joints within the construction should be waterproof. Consideration should also be made for protecting the structure from sulphates or any other progressive contaminants that may exist within the soil.

The structure can be waterproofed with Newton System 500 to protect the dry internal habitable areas from any leakage that may occur through the concrete structure. Vertical surfaces should be waterproofed with Newton 503, 508 or 508R. Newton Basedrain should be installed at the wall floor junction, with Newton Floordrain channel at all joints within the structure in case of leakage. Newton 508R, Newton 508 eco Floor, Newton 503, Newton 520 eco should be used as the flooring membrane. See technical drawing JN5018 & JN5019

Note: In all cases, provision should be included to remove the water collected by the Newton System 500 waterproofing system. Newton System 500 is not a hydrostatic barrier, and it will fail if water pressure comes to bear against any of the membranes of the waterproofing system. Water should be removed to either a sump chamber to be pumped out of structure, or to safe forms of natural drainage, where it is impossible for water to backup and either pressurise the system or prevent water from leaving the Newton waterproofing system, such as a drainage collection point that is down hill and so below the level of the slab or raft of the structure.

It is Newton's opinion that waterproofing systems should be designed and installed by experts in the waterproofing of below ground structures. Our Newton NSBC contractors are experts in both the design and installation of our systems, and we recommend that designers should use their expertise wherever possible. Most of our NSBC contractors carry professional design liability insurance, and are able to take on board the design and installation risk away from the main contractor/client/architect.

SECTION 3. PREPARATION

3.1 PREPARATION

Newton System 500 can be installed over a wide range of substrates in varying situations - walls, floors, ceilings, soffits, etc. However, before the system is installed, the area must be assessed to determine what preparation is required:

- All timber and other organic material must be removed to prevent risk of fungal or bacterial growth behind the System, e.g. skirting boards, timber plates, old wallpaper etc. If evidence of rot exists, this must be dealt with by a specialist contractor prior to installation of the system. If any mould, etc. exists, this should be cleaned off and the area sterilised with a fungicidal wash
- If the walls are uneven or areas have deteriorated, any large depressions should be levelled and made good to ensure a solid fixing
- When assessing floor applications, consideration should be given to the type of finish that is required. The floor must be cleared of oil, loose material and any sharp protrusions and should be made level. Any holes or severe depressions should be filled. When a timber floor is preferred, then more consideration should be given to achieve a flat substrate prior to laying the membrane. This will relieve any undue movement when fitting the floor covering
- The design of the drainage system should be agreed, implemented and tested before covering by the membrane. The exception to this is where the Basedrain is sat above the slab or raft. Flood tests should be made to check the slab or raft is flat and level prior to the installation of the Basedrain, but the system can only be fully tested once the floor membrane and some form of resistance to water pressure is placed above the membrane such as temporary boards with bags of ballast or sand placed above, or the finished floor covering
- When fixing the system to flat soffits you must ensure that there is a fall to create proper drainage and prevent ponding. Any sagging of the membrane should not be great enough for ponding to take place
- New concrete should be treated with Newton 106 Lime Inhibitor which prevents free lime from the curing concrete being drawn out by ingressing water. (See our web site for more information)

SECTION 4. WALL APPLICATION NEWTON 508 & 508R

4.1 TOOLS

Minimum Requirement

- Good quality 110V SDS hammer drill
- Mallet or club hammer
- Stanley Knife with spare blades
- Tape measure
- Long spirit level
- 10mm or 11mm SDS drill bits depending on which plugs are used
- Clean rags
- Staging or scaffold for safe working at height
- PPE - Gloves and safety glasses

Recommended

- Extra lighting
- 110V Hot Air Gun
- Revolving laser level

4.2 WALL APPLICATION

Newton 503, Newton 508 or Newton 508R membrane is fixed with the studs against the wall to create an air/depressurisation gap.

The membrane can be fixed either vertically or horizontally. When making this decision, you will need to take into account the size of the area to be lined, and the height of the walls relative to the width of the membrane. Horizontal fixing requires less cuts and jointing but the full roll is very heavy at first. Vertical fixing has much lighter strips to fix, but requires that each of these is taped back together again. You may find that vertical fixing is easier, but requires more Waterseal Tape for jointing.

The membrane is fixed to the wall with the Newton MultiPlug. The MultiPlug has a soft rubber sealing washer fitted to the plug for sealing to the wall membrane.

Place the Newton wall membrane in position as level as you can judge by eye. Using a 10mm drill bit, drill through the centre of a stud near the top and edge to a depth greater than the fixing. The fixing is then hammered into the pre-drilled hole until the plug sits flush in the stud. The rubber washer re-seals the hole. Level the membrane using the spirit level or laser level if used, and fix another plug about 2m along at the top of the sheet. The membrane will now be hanging level to the wall.

If you are fixing horizontally, continue fixing every 2m until you have reached the end of the roll or you have covered all of the wall(s) to be treated. It is very important to regularly check the level. If the membrane is not level, you may well find that the membrane is kinked and looks unsightly, it will also dive down when fitted around corners.

If you are fixing vertically, hang each subsequent sheet by the two fixings as described above. The subsequent sheet should overlap by at least the width of the flange of the new sheet. You may find it easier to interlock the first stud of the new sheet to the last stud of the last sheet as this helps to keep the new sheet level. The vertical joints have to be sealed with Waterseal Tape. It is easier to apply the tape to the inner surface of the flange of the next sheet. Clean the flange and the face of the last sheet with a clean rag. When you have fixed the new sheet level with the correct overlap, pull off the backing paper from the tape and peel down whilst applying pressure to the flange. Once all the backing paper has been removed, apply more pressure with the palm of your hand to further seal the whole of the joint. A Hot Air Gun should be used to help sealing, especially in cold or damp conditions.

4.3 FIXING CENTRES

Once the wall membrane is hanging from the top fixings the rest of the fixing plugs need to be fixed.

The spacing of these fixings is dependant on the type of wall finish to be used:

- Timber battens - 600mm centres vertically and 400mm horizontally
- Barrel Vaults - Tighter centres 300mm around the vault and 600mm down the vault
- Fixed metal track (Gypliner) - 800mm centres vertically and 600mm horizontally
- Brick or block walls restrained to the retaining wall using ties should have the fixings at centres to provide the correct number of restraints at the correct centres
- Free standing timber and metal frames and free standing block walls do not require specific fixing centres. In these cases use sufficient fixings to ensure the membrane is neat and tidy and reasonably tight to the wall, especially around corners and reveals
- When fixing the system to vaulted soffits you must ensure that enough fixings are used to keep the wall membrane tight to the soffits with no sagging
- All fixings should be in line both horizontally and vertically

4.4 BATTENS

Battens should be pre-treated and of a minimum dimension of 25mm x 38mm although you may find that 25mm x 50mm offers better fixing at the edge of the plasterboard.

The battens can be fixed into the MultiPlug without piercing the membrane, by using 5mm (size 10) self-tapping screws. The plug will take 30mm of screw, so be sure to purchase the correct length for the thickness of batten.

Over-tightening of over length screws can loosen the plug. Be very careful not to puncture the wall membrane when drilling and fixing the battens. Battens should be fixed so that all plasterboard edges are supported. Use a timber treatment such as 'End Cut' to protect cut battens.

Once the battens are fitted into position, plasterboard can be fixed to them using clout nails or preferably plasterboard screws. Care should be taken not to exceed the depth of the battens with the screws, and thereby puncture the membrane.

4.5 ALTERNATIVE FIXINGS

Other finishes may be employed depending on the requirements of the specifier.

Free Standing Frame

This method should be employed if the wall is undulating, as with some stone structures or where space loss is a secondary consideration. The frame would be fixed to the soffit and the floor finish with the supplied 'U' channels. With the increasing requirement of insulation to meet Part 'L' of building code, the use of these frames is becoming more popular, the thickness of insulation required is often in excess of the thickness of the frame, and so the use of these frames does not add extra depth to the wall build when using this method. Because the frame is free standing and has no relationship with the wall membrane, very few fixings are required and so this wall finish above allows for the fastest and most efficient method of fixing Newton 508 to the wall.

Proprietary Fixing Systems

Fixing systems such as Gypliner or Lafarge can be used with Newton System 500. It is also possible to use metal profile systems when constructing new internal walls.

Internal Block Walls

If preferred the system can provide a water and vapour proof barrier, and then be lined with a block or brick inner skin. Special ties are available that fit into the Newton MultiPlug for lateral restraint of the internal wall. The ties and retaining clips can also be used for the fixing and holding in place the wall insulation.

SECTION 5. WALL APPLICATION NEWTON 503 MESH & 508 MESH

5.1 FIXING TO WALLS

The wall membrane is fixed to the walls in the same way as in the section above using the Newton MultiPlug. As the rolls are heavier and not available in 2.4m high rolls, most fixing of Newton Meshed membranes will be vertical.

5.2 FIXING CENTRES

Fix in a square at 350mm centres, and then fix a plug in the centre of four fixings so it looks like a 5 on a dice. All fixings will then be a maximum of 250mm centres. On very flat walls, the horizontal and vertical centres can be moved out to 400mm so when the centre plug is fixed, the centres are not more than 300mm.

5.3 FINISHES

Newton Meshed membranes can be plastered or rendered, or can be plaster boarded using a dab fix.

5.3.1 PLASTERS

The recommended plaster to be applied to Newton 508 Mesh is Tarmac Whitewall, supplied by Newton Waterproofing, which should be in two coats when applied to Newton Mesh Membranes. The plasters can accept a finishing 3mm skim coat to finish.

Note: Manufacturers recommended drying times may vary according to atmospheric conditions.

5.3.2 CEMENT BASED RENDERS

For internal cement renders the mix should be six parts clean sharp sand/one part lime/one part cement. A two-coat application is recommended allowing 7-10 days between coats. Drying time is important because shrinkage cracks may appear. A weaker mix of seven or even eight parts sand can be used for the second coat.

5.3.3 HYDRAULIC LIME BASED MORTARS

First Coat

Using a ratio of 1 part Lime to 2 1/2 - 3 parts sharp washed sand with evenly distributed hair throughout the mortar and working to a layer of 10mm thick, push the plaster into and across the pre-wet laths at a 45 degree angle to the lathes.

The plaster should be correctly cured until hard

Second Coat

The second coat also known as the intermediate or float coat will be applied similar to the first coat only without any hair being added to the mortar. You must ensure you wet down the first coat with a fine mist before spreading a 7mm coat, before scratching up and leaving in preparation of the finish coat.

Finish Coat

For the final top coat a fine mix of 1 part lime putty to 2 parts well graded super fine sand. Remembering to wet down the surface before application with a fine mist spray. Allow time for the water to absorb into the plaster then apply a coat of approximately 5mm, then rule off and leave for a couple of hours. When ready, rub up the finish coat using a plastic or wooden trowel to bring back the fat until the required finish has been reached in the case of any light crazing this can be rubbed up and trowelled out.

5.3.4 GENERAL PLASTERING & RENDERING CONSIDERATIONS

Note: All plasters and renders etc. must be to a minimum total depth of 15mm. The undercoat should be applied with firm pressure to ensure the product is fully pushed behind the mesh so that the studs are fully filled, and to an approximate thickness of 5mm and be well scratched with a wire scratcher. When the scratch coat has set, the floating coat should be applied to a depth of 7mm and lightly scratched to provide a firm key for the final coat, which should be to a minimum thickness of 3mm.

All plasters and renders should be applied strictly in accordance with the manufacturer's instructions, and good plastering/rendering practice as described in BS5492 and BS5262 Code of Practice.

Do not apply decoration until the plaster or render is thoroughly dry.

Note: If plasters other than those specified above are used they will not conform to the Newton Waterproofing specification and will therefore invalidate any guarantee on the material. If any special renders or plasters are to be considered, technical advice must be sought from the Company's technical department.

5.3.5 CURING

Note: Cement and Lime based mortars require curing. Curing is the process of keeping a mortar or render under a specific environmental condition until the chemical set (referred to as hydration) is sufficient to withstand the environment into which the mortar has been placed. Lime binders are generally weaker than cements taking longer to acquire their strength and hardness, leaving them potentially more vulnerable for a longer period than cement equivalents, and curing them once placed is simply regarded as best practice.

Good curing is typically considered to be that of providing a humid environment stimulating full hydration of the lime or cement binders, providing strength development along with other benefits, especially the ability to withstand hairline cracking. The most common cause of failure is allowing a mortar/render to dry out too quickly, impeding the chemical process for hydration, stressing the mortar resulting in cracking.

Standard practice for protecting cement or lime based renders/mortars is with wet/dampened hessian sheeting draped over the area in relatively close proximity to the render. This should be left in place for at least a week and is a standard requirement that is required in all cases. During the warmer months, the hessian will need to be repeatedly wetted and/or covered with plastic sheeting to ensure the correct curing environment.

Curing should be of at least 7 days.

5.3.5 DRY LINING

Newton Meshed Membranes can be effectively used in conjunction with dry lining by dab fixing the plasterboard using a proprietary dabbing compound. Be careful when installing laminated or insulated plasterboard, as when they are dot & dabbed to Newton System 500 Meshed membranes, building regulations require two mechanical fixes to each laminated board. These fixings may breach the membrane which cannot be repaired. Where insulation is required to the wall build, we recommend to use un-meshed Newton 508, 508R or 503 and use an independent dry-lining frame. House the insulation within the frame and plasterboard over.

SECTION 6. FLOOR APPLICATION NEWTON 508R & 508 ECO Floor

6.1 PREPARATION

Please refer to our section on preparation and attend to any preparatory work prior to installation. Always clean both edges of the membrane before making a seal.

6.2 DRAINAGE REQUIREMENT (DRAWINGS JN5017/JN5018/JN5019)

When used in a full or part earth-retaining situation, the membrane system must be drained. To comply with BS 8102:2009, you must assume that the structure will be subjected to water ingress at some time. Newton Flooring Membranes can also be installed over the floor in above ground situations to provide isolation from damp floors either as the primary DPM or above green concrete to accelerate the contract program. The concrete will continue to cure below the dry membrane surface allowing for floor finishes to be laid above the membrane much quicker than normal.

6.3 METHODS OF DRAINAGE FOR NEWTON FLOOR MEMBRANES WITHIN SYSTEM 500

The drainage must effectively remove all water from below the membrane and take the water to a point of discharge such as a sump chamber or a form of safe natural drainage. Standing water can block the membrane with silt or lime scale so it is important for water to flow uninterrupted to the drainage point.

6.3.1 BASEDRAIN

Basedrain is placed at the wall/floor junction and collects water from behind the wall membrane and receives water at the wall/floor junction. Basedrain is a designed method of removing water as it can interface with sump chambers, gullies, waste pipes etc. It can also be maintainable by inserting Newton Inspection Ports into the system. (see drawings JN5017 to JN5021 within the drawing appendix starting on page 26)

6.3.2 BASEBOARD

With existing floors and where there is insufficient headroom to use the Basedrain drainage system within a spacer of Newton Fibran XPS Insulation, Newton Baseboard can be used as the drainage system. Please see drawing JN5028.

6.4 INSTALLATION OF NEWTON 508R & 508 ECO FLOOR MEMBRANE - EARTH RETAINING

Starting at one side of the room, unroll the membrane with the studs down and cut to fit the room as one would a carpet. The next membrane width is rolled out so that the flanged edge overlaps onto the edge of the previous roll of membrane. Clean both edges. Waterseal Tape is then applied to the high flat area between the first two studs at the edge of the previous roll of membrane with the backing paper still intact. Check the two widths for alignment, with the flange covering the backing paper. Starting from the end of the joint, remove the backing paper and press down on the joint sealing the two sections together. This process is repeated until all areas are covered.

Seal the Newton floor membrane to the up-stand of the Newton Basedrain perimeter drainage channel with Newton Overtape. Use a heat-gun to dry the membrane surface and to assist with the bonding of the tapes.

Where the floor membrane is required to be jointed to horizontal DPC's, such as Newton 809-DPC, through internal and external walls, these joints should be sealed with Newton Waterseal Tape. Ensure both surfaces are clean and dry before attempting to make these joints.

If there are any services through the floor, the membrane can be cut and trimmed around them, and the gap filled and sealed using the Newton range of adhesives. If necessary, a patch of membrane or Newton 809-DPC is laid over and sealed to the service with Waterseal Rope, and around its perimeter with Waterseal Tape. Alternatively, Newton Pipe Collar or Newton Pipe Sleeve can be used. It should be noted that protrusions through the floor slab/raft should be avoided wherever possible as they create weaknesses that allow unnecessary water ingress.

The specified floor finish can now be laid directly over the floor membrane, which must not be punctured by any fixings through the floor. When a timber floor finish is preferred you must allow an expansion gap around the wall edge. Speak to the supplier of the floor finish to confirm the correct size of this expansion gap.

6.5 FAST TRACK APPLICATION OF FLOOR FINISHES

Following the installation of new concrete slabs and screeds, it is normal to expect lengthy drying periods before floor finishes can be applied. The membranes can be laid onto green concrete as soon as it is 'walkable', allowing instant application of floor coverings without reference to RH levels. The construction moisture is controlled in the air gap.

SECTION 7. FLOOR APPLICATION NEWTON 520 ECO

It is very rare for water to pass through a solid concrete slab or concrete raft, but where the slab or raft is of questionable quality it is possible for water to pass through cracks in a poorly constructed floor. If the quality of the slab is questionable, Newton 520 eco should be used as the floor membrane.

7.1 INSTALLATION

Starting at one side of the room, unroll the membrane with the studs down and cut to fit the room as one would a carpet. The next membrane width is rolled out so that the flanged edge overlaps onto the edge of the previous roll of membrane. Clean both edges. Waterseal Tape is then applied to the high flat area between the first two studs at the edge of the previous roll of membrane with the backing paper still intact. Check the two widths for alignment, with the flange covering the backing paper. Starting from the end of the joint, remove the backing paper and press down on the joint sealing the two sections together. This process is repeated until all areas are covered.

Seal the Newton 520 eco Membrane to the up-stand of the Newton Basedrain perimeter drainage channel with Newton Overtape.

Where the floor membrane is required to be jointed to horizontal DPC's through internal and external walls, these joints should be sealed with Newton Waterseal Tape. Ensure both surfaces are clean and dry before attempting to make these joints.

If there are any services up through the floor, the membrane can be cut and trimmed around them, and the gap filled and sealed using the Newton range of adhesives. If necessary, a patch of membrane or plain DPC is laid over and sealed to the service with Waterseal Rope, and around its perimeter with Waterseal Tape. It should be noted that protrusions through the floor slab/raft should be avoided wherever possible as they create weaknesses that allow unnecessary water ingress.

The specified floor finish can now be laid directly over the floor membrane, which must not be punctured by any fixings through the floor. When a timber floor finish is preferred you must allow an expansion gap around the wall edge. Speak to the supplier of the floor finish to confirm the correct size of this expansion gap.

SECTION 8. VAULT APPLICATION

Newton 508, Newton 508R or Newton 508 Mesh can be used for Vaults or Vaulted soffits

8.1 INSTALLATION TO VAULTS OF NEWTON 508. 508R AND NEWTON 508 MESH (DRAWING JN5021)

A ceiling which is to be covered, as in a vaulted cellar construction, should be fixed and lapped in such a way so that water does not pond behind the system. The laps and joints should also be detailed correctly to allow correct drainage, and prevent water from sitting on joints. Newton Nuseal Plugs or Newton MultiPlug, with a seal made from Waterseal Rope, should be used for application to vaulted ceilings. Where flat soffits are being considered it is imperative that they should have a fall in line with drainage requirements. Again, sagging of the membrane should be avoided to prevent ponding. If in doubt about soffits speak to our Technical Department.

8.2 DRAINAGE

See section 6.2 and 6.3

8.3 APPLICATION

Where Newton System 500 is to be installed in vaulted cellars our experience shows that the best method of application is as follows:

Measure the depth of the vault from front to back wall and allow for a down turn at each end of 200mm. Unroll the sheet and cut to size.

Estimate the approximate centre of the arched ceiling and mark it. Measure down the arch 1.2 meters from there and again mark it. Strike a horizontal line along the wall from back to front. This will give you a guide line for your sheet edge as you fix it along the length of the ceiling, thereby keeping your sheet sections symmetrical. You may wish to hammer in masonry nails to the guide line to give a physical edge to the guide line.

Offer up your first section of membrane to the ceiling allowing a lap to the back wall of 200mm. Using your guide line to keep the sheet square, drill and fix the sheet along the apex of the arch following the same line of studs. You will use the Newton MultiPlug or the Nuseal Plug, using Waterseal Rope to seal the plugs. **NOTE: The rubber washer sold with the MultiPlug is not suitable. Order the plugs without washers and use the Waterseal Rope to effect the seal.** The fixings should be fixed through the centre of the membrane studs at approximately 600mm centres. It should be remembered that the plugs provide the fixing points for your battens; therefore they should be kept in line.

Your next section of membrane is again cut to size allowing a 200mm lap at each end. Before offering up the next sheet, a Waterseal Tape joint should be applied to the edges of the first sheet, either on the flanged edge or between the last two rows of studs on the non-flanged edge. With the protective paper left on the tape you can now offer up the next sheet ensuring that you use the flanged edge to overlap onto the sealing tape.

Once you have the second sheet positioned correctly over the sealing tape, remove the protective paper working out from the middle and effect a seal.

You can now carry on fixing the sheet as previously described. This process is repeated until you have covered the arched walls to the springer and the vertical walls below the springer, maintaining a 200mm lap to the end walls.

8.4 VAULTS - END WALLS

At the end walls of the vaulted construction an 'end piece' of flat membrane is fitted to the end wall of the vault. The 200mm lap from the soffit membrane is cut in fans to fit the curve and sit neatly against the wall, filling each cut with a small piece of Waterseal Rope or Waterseal Tape. Do not make the cuts all the way up to the ceiling and make as few cuts as possible.

Measuring the highest point of the arch, the 'end piece' membrane is cut to size and fixed to the end walls in front of the fanned ceiling membrane. The membrane is then trimmed to fit neatly into the curve of the ceiling.

The end wall membrane is then pulled back at the sides and around the arch to expose the studs on the reverse side. Using Waterseal Rope, a joint is made by the same method at the stud/stud joint details, with the exception that around the arch the rope should follow the contour of the ceiling curve.

8.5 FLOORS

Where a floor application is required in this situation, which is common practice in this type of specification, it is laid as per our standard floor installation (see 6.4 and 7.1). If a floor membrane is not installed you should still provide for the correct drainage facility.

8.6 DOOR REVEALS

When you fit the Newton membrane to the end wall with the door opening, please bear in mind that you will have to fit a section of membrane around the door head and lapped down the sides by approximately 100mm. You can then wrap the wall membrane around the sides, maintaining the correct drainage detail and forming an overlap.

This application detail will produce a small gap on the angle of the door opening. This should be sealed using Newton Overtape. Alternatively, Newton Slimline membrane can be used a flat DPC in lieu of the studded membrane if space is limited.

8.7 OVERHEAD INTRUSIONS

Where service pipes, electrical wiring or other intrusions occur overhead or around the arch, these should be re-sited to a vertical surface where they can be better sealed and re-situated on the dry side of the system. Most services can be concealed between the battens. Services and protrusion should be collated where possible and passed through a pipe sealed with one of the Newton pipe sleeve options.

SECTION 9. SEALING INSTRUCTIONS

9.1 GENERAL

It should be noted that all membrane and sealing surfaces must be clean, dry and dust free before applying sealing materials. When making a joint between two sections of membrane, the water seal tape or rope should be pressed firmly against the Newton membrane for good adhesion.

There are two standard types of sealed joints that can be made: The flanged joint or stud/stud joint.

9.2 NEWTON 508, 508R & 508 MESH

9.2.1 THE FLANGED JOINT - (Drawing JN5022-A)

The Flanged Joint should be used whenever the flat flanged edge of System 500 is available. Consecutive membrane widths are fixed to the walls or laid on the floor so that the flange lays over the top of the studded edge of the previous sheet. The flange must cover a minimum of two rows of studs. Using the Newton Waterseal Tape, unroll this onto the studded edge sheet, beneath the flange. The tape should be positioned between the last two rows of studs on the flat section, and pressed firmly into place.

The backing paper should still be on the tape at this point.

Check that the flanged edge of the upper membrane is in position and covering two rows of studs before removing the backing paper from the tape.

Once the flanged edge is in position, remove the tape's backing paper. Press the two membrane layers together firmly as you remove the protective backing paper.

9.2.2 THE LOCKED FLANGED JOINT - (Drawing JN5022-B)

This joint is similar to the 'Flanged Joint' (8.2.2), but has the first line of studs of the next sheet of Newton 508 interlocking with the last line of studs on the previous sheet of the membrane. This method is used where you wish to guarantee that the next sheet of membrane is laid or fitted exactly square to the previous sheet and is useful on large floors or where the wall membrane is fitted horizontally and a horizontal joint is required.

9.2.3 THE STUD INTO STUD JOINT - (Drawing JN5022-C)

Where a 'Flanged Joint' is not possible, and where the studs from each sheet line up correctly so that they interlock into each other, a 'Stud into Stud' joint is possible. The overlap should be a minimum of three studs. Waterseal Tape is used to achieve a flat joint. Attach the Waterseal Tape to the flat area between the last two studs of the previous sheet of membrane with the backing tape still adhered. Carefully remove the backing tape and push the next sheet studs into the previous sheet studs to create the flat joint.

9.2.4 THE STUD OVER STUD JOINT - (Drawing JN5022-D)

Where a 'Flanged' or 'Stud into Stud' joint is not possible because the studs do not interlock, a 'Stud over Stud' joint is used. Overlap the membranes to be joined by a minimum of three rows of studs. The joint is then formed by using Newton Waterseal Rope.

This is done by lifting back the edge of the upper membrane to reveal the underside of the studs.

The Waterseal rope is then positioned between the last two rows of studs, and pressed firmly into place.

Checking that the upper membrane is still positioned correctly, remove the rope's backing paper. Press the two membrane layers together firmly as you remove the protective backing paper.

Note: When making a 'Stud over Stud' joint always position the rope between the studs on the reverse side of the membrane, and not on the surface you are sealing to. This will ensure an even seal.

9.3 NEWTON 503

9.3.1 BUTTED JOINT - (Drawing JN5023-A)

Newton 503 does not have a flange, so a butted joint is used.

Starting at one side of the room, unroll the membrane with the studs down.

The next membrane width is rolled out so that edges of the two rolls meet at a 'butt joint'. Clean both edges. Newton Overtape (150mm wide) is then applied above the butted joint to join the two widths of membrane. Newton Overtape has a split backing paper, and it is easier to apply the Overtape to one roll and then the other by removing half the backing paper at a time. This process is repeated until all areas are covered.

9.4 NEWTON 520 ECO

9.4.1 FLANGED JOINT - (Drawing JN5023-B)

The flanged joint should be used whenever the flat flanged edge of Newton 520 eco is available. Consecutive membrane widths are laid on the floor so that the flange lays over the top of the studded edge of the previous sheet. The flange must cover 70mm of the previous sheet of membrane. Using the Newton Waterseal Tape, unroll this onto the studded edge sheet, beneath the flange.

The tape should be positioned between the last two rows of studs on the flat section, and pressed firmly into place.

The backing paper should still be on the tape at this point.

Check that the flanged edge of the upper membrane is in position and covering two rows of studs before removing the backing paper from the tape.

Once the flanged edge is in position, remove the tape's backing paper. Press the two membrane layers together firmly as you remove the protective backing paper.

9.4.2 BUTTED JOINT - (Drawing JN5023-C)

Where the flange is not available, a butted joint is used.

Starting at one side of the room, unroll the membrane with the studs down.

The next membrane width is rolled out so that edges of the two rolls meet at a 'butt joint'. Clean both edges. Newton Overtape (150mm wide) is then applied above the butted joint to join the two widths of membrane. Newton Overtape has a split backing paper, and it is easier to apply the Overtape to one roll and then the other by removing half the backing paper at a time. This process is repeated until all areas are covered.

9.5 NEWTON 601 SLIMLINE

9.5.1 FLANGED JOINT - (Drawing JN5023-D)

The flanged Joint should be used whenever the flat flanged edge of Newton 601 Slimline is available. Consecutive membrane widths are laid on the floor so that the flange lays over the top of the studded edge of the previous sheet. The flange must cover a minimum of two rows of studs.

Using the Newton Waterseal Tape, unroll this onto the studded edge sheet, beneath the flange.

The tape should be positioned between the last two rows of studs on the flat section, and pressed firmly into place.

The backing paper should still be on the tape at this point.

Check that the flanged edge of the upper membrane is in position and covering two rows of studs before removing the backing paper from the tape.

Once the flanged edge is in position, remove the tape's backing paper. Press the two membrane layers together firmly as you remove the protective backing paper.

9.5.2 FLAT JOINT – NO FLANGE

Because Newton 601 Slimline is flat and not studded, where the flange is not available, the sealing is carried out as with the flange.

SEALING AT:

9.6 SERVICE THROUGH FLOORS AND WALLS (Drawing JN5024)

Occasionally, service pipes and other intrusions will interrupt a continuous application of the membrane. In this instance the membrane should be trimmed neatly around the service and sealed using the Waterseal Rope or Newton Overtape, or if necessary a combination of both. If necessary, a patch of Newton 809-DPC can be overlaid and sealed to the service around its perimeter using the Newton range of sealing products.

Alternatively, Newton Pipe Collar or Newton Pipe Seal preformed collars can be used to seal around the protrusion.

9.7 OVERLAP JOINTS

On walls, System 500 can be fixed either vertically or horizontally. System 500 is overlapped either by the flanged edge or by a minimum of three rows of studs.

9.8 GENERAL

In all cases ensure that membrane overlaps are made so as to provide continuous drainage behind the System. Avoid making laps that would allow water to drain onto or to be trapped by the joints.

SECTION 10. VENTILATION

10.1 GENERAL

Ventilation is an important requirement of the design of habitable building space, and is necessary for providing a healthy environment for all of the building occupants.

Part F (2006) of the Building Regulations 2000 deals with ventilation within buildings. Requirement F1 states that "There shall be adequate means of ventilation provided for people in the building".

Ventilation is required for one or more of the following purposes:

1. Provision of outside air for breathing
2. Dilution and removal of airborne pollutants, including odours
3. Control of excess humidity (arising from water vapour in the indoor air)
4. Provision of air for fuel-burning appliances (which is covered under Part J of the Building Regulations)

Ventilation is increasingly more of an issue because of the requirements of Part L of the Building Regulations 2000 to make houses more air-tight so as to prevent heat loss. The two sections of the Building Regulations appear to be almost at odds with each other resulting in the requirement for mechanical ventilation in most cases.

Basements present even more of a problem as natural ventilation, even in older properties not subject to Part L, is a real problem where the living space walls may be earth retaining to all elevations.

BS 8102:2009, the code of practice for the protection of structures against water from the ground, mentions the need for ventilation for Grade 4 structures to be used for the storage of hygroscopic materials such as for the archiving of paper documents. Although BS 8102:2009 does categorise Grade 3 habitable areas as being ventilated, unfortunately the British Standard pre-dates the current Part F by some sixteen years, and so is not giving advice that is up-to-date. If BS 8102:2009 were to be updated today, it would include specific guidance for the forced mechanical ventilation of Grade 3 habitable areas, controlling humidity to around 50% RH.

It is unlikely that works to waterproof a basement will comply with Part F unless mechanical ventilation is included, and so we recommend that mechanical ventilation is included within the design of all Newton Waterproofing Systems.

The following tables are taken from Part F and show the rates of ventilation for different areas of a property, and in 1.1b for the whole house.

1.1.a EXTRACT VENTILATION RATES

Room	Minimum Intermittent Extract Rate	Continuous Extract	
		Minimum High Rate	Maximum High Rate
Kitchen	30 L/s (adjacent to hob) or 60L/s (elsewhere)	13 L/s	Total extract rate must be at least the whole building ventilation rate as shown in Table 1.1.b
Utility room	30 L/s	8 L/s	
Bathroom	6 L/s	8 L/s	
Sanitary accommodation			

1.1.b WHOLE BUILDING VENTILATION RATES

Whole building ventilation rates ^{a,b} (L/s)	Number of bedrooms in dwelling				
	1	2	3	4	5
	13	17	21	25	29

Notes:

- a. In addition, the minimum ventilation rate should not be less than 0.3 L/s per m² internal floor area (this includes each floor, e.g. for a two story building, add the ground floor and first floor areas)
- b. This is based on two occupants in the main bedroom, and a single occupant in all other bedrooms. This should be used as the default value. If a greater level of occupancy is expected, then add 4 L/s per occupant

10.2 VENTILATION SYSTEMS FOR BASEMENTS

Part F names 4 methods of ventilation:

1. System 1 - Background ventilators and intermittent extract fans.
2. System 2 - Passive stack ventilation.
3. System 3 - Continuous mechanical extract.
4. System 4 - Continuous mechanical supply and extract with heat recovery.

For a dwelling which includes a basement that is connected to the rest of the dwelling above ground by a large permanent opening (e.g. an open stairway), the whole dwelling including the basement should be ventilated and treated as a multi-storey dwelling. If the basement has only a single exposed façade, while the rest of the dwelling above ground has more than one exposed façade, ventilation systems 3 and 4 are preferred. If systems 1 or 2 are to be used, seek expert advice.

For a dwelling which includes a basement that is not connected to the rest of the dwelling above ground by a large permanent opening the basement should be treated separately as a single-storey dwelling above ground. If the basement has no bedrooms, assume it has one bedroom for the purpose of determining ventilation provisions.

For a dwelling which comprises only a basement it should be treated as a single-storey dwelling above ground.

10.3 CONTINUOUS MECHANICAL SUPPLY AND EXTRACT WITH HEAT RECOVERY SYSTEMS

Continuous mechanical supply and extract with heat recovery systems (Heat recovery ventilation systems) are the easiest of the systems to specify as they do not require any background ventilators, whereas the other three systems require one background ventilator in each habitable room.

Heat recovery units are also the most efficient of ventilation systems, recapturing up to 90% of the indoor warmth that would otherwise be lost.

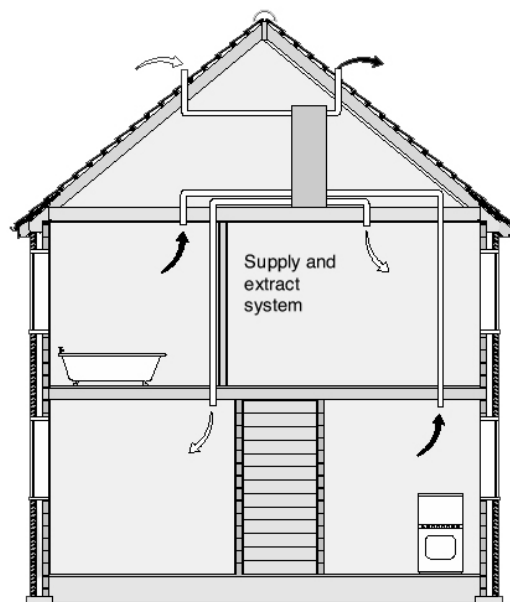

10.4 VENTILATION SYSTEMS FOR BASEMENTS

Interstitial condensation occurs when water vapour held in the air (humidity) condenses on a surface that is below the 'dew-point'. Warm air holds more moisture than cool air, and so if a cool surface reduces the local air temperature, the air is unable to hold all of the moisture previously held when the air was warmer, resulting in condensation forming as droplets to the cold surface in question. This becomes interstitial condensation when the dew-point temperature occurs within the main fabric of the building, such as the inner face of the waterproofing membrane where an internal block wall has been built in front of the membrane for example.

The warmer the air, the more moisture that can be held – the cooler the air, less moisture can be held. Therefore the risk of condensation can be massively reduced by removing the amount of humidity in the air, and as Part F confirmed on pages 22 & 23, one of the reasons we have ventilation is for the control of excess humidity arising from water vapour within internal atmosphere.

The risk of condensation has been increased in recent years with the requirement for more and more insulation to comply with Part L of the Building Regulations. Insulation prevents heat loss due to the insulation having high thermal resistance values. As a result, less heat is arriving at the face of waterproofing membranes and so these surfaces are cooler and therefore more likely to reach the dew-point temperature. Again, this risk can be very much reduced by controlling the Relative Humidity (RH) with ventilation.

10.5 COLLECTION OF CONDENSATION WITH NEWTON SYSTEM 500

Even though we recommend that ventilation is included within all Newton Waterproofing Systems, we have included within the design of System 500 a safety mechanism that will intercept condensation should it occur on the face of the membrane. It is possible for human or mechanical intervention preventing the ventilation system from keeping the RH at safe levels. The Newton System includes a spacer to accept condensation that has formed on the surface of the wall membrane. This is in the form of spacers to the rear of the Basedrain drainage channel, or where floor finishes are deeper, Newton Condensation Strip should be used. Vapour is prevented from rising up from the condensation gap by a blanket of positive air pressure as a result of cool air falling and trapping the even cooler air within the Basedrain.

10.5.1 BASEDRAIN SPACERS – (Drawing JN5010-2)

Newton Basedrain has a series of spacers on the reverse side of the up-stand to the side that contacts the Newton wall membrane. If condensation did form on the face of the Newton wall membrane, the gap provided by the spacers will receive the condensation into the drainage channel.

10.5.2 CONDENSATION GAP USING NEWTON CONDENSATION STRIP – (Drawing JN5010-1)

Where the screed depth is greater than the 60mm back flange of the Basedrain, Newton Condensation Strip to provide the condensation gap. The conclusion of the Technical Committee of the Structural Waterproofing Group was that the condensation gap be left open unless there is a good enough reason for it to be closed, and we agree with this conclusion.

10.5.3 SEALING THE CONDENSATION GAP

There are situations where the sealing of the condensation gap is a necessity, such as where the Newton Waterproofing System is also used as a gas barrier. If the condensation gap is sealed, it is imperative that the ventilation system is always working as designed.

SECTION 11. REPAIRS

11.1 REPAIRS TO STUDS

If the wrong stud is drilled in error this can easily be repaired by cleaning out the stud with a clean cloth and plugging it with Waterseal rope. This can then be covered with a small patch of Overtape.

The same repair can be used where a successful fixing has not been achieved due to drilling into unsound joints or structure and where the MultiPlug expansion pin has not been successful. Simply make the repair and re-drill another stud.

11.2 REPAIRS TO MEMBRANE – SYSTEM 500 (Vertical Walls)

11.2.1

If the membrane is accidentally cut or pierced this can be repaired by cleaning the surfaces with a clean cloth and using Overtape. Seal along the length of the cut bridging both edges and also extending beyond the two furthest points of the cut by 25mm.

11.2.2

If the membrane is ripped causing a ragged cut, this will need to be sealed using Newton Overtape, using the same method as above.

11.2.3

If the membrane is damaged and a hole is created, this can be bridged by using Overtape providing the hole can be bridged in one piece with at least a 25mm margin around the hole.

Larger holes can be bridged by cutting a piece of System 500 to cover the hole and allowing a margin beyond the hole size. This can then be sealed in two ways:

1. If the repair membrane sits neatly into the studs the edges can be sealed using Waterseal Tape over the repair section and lapping onto the main section. Seal around perimeter.
2. Alternatively, if the studs don't interlock, a ridge will be formed and you will need to use Overtape to bridge around the perimeter of the repair patch onto the main section.

11.3 REPAIRS TO FLOORS/VAULTED CEILINGS

Where damage to a floor or vaulted ceiling occurs this can be repaired using the same methods as above, but you must always use the Overtape to bridge or seal the damage.

It is imperative that all surfaces to be sealed are clean and dry before making the repair. In some instances it is acceptable to warm the membrane and the Overtape prior to making the seal with a hot air gun to alleviate any surface moisture.

11.4 GENERAL

All the above repair procedures require access to the System to achieve a proper repair. This will involve removing any finishes to gain access, although it should be said that once the finishes are in place damage should not occur. In the case of screeded floors, the screed must be removed to access the damage. This must be done with extreme caution to prevent further damage to the membrane.

Note: Where multiple damage has occurred on a section of membrane it may be advisable to cut out and replace a large section of membrane.

SECTION 12. MAINTENANCE

12.0 MAINTENANCE

Newton System 500 requires very little maintenance. However, there are a number of points you should be aware of, and indeed your client should also be made aware of in the content of your survey report/contract documents.

12.1 CHECKS PRIOR TO FINISHES

During the installation of the System, any repairs that are required should be carried out as they occur. This will save time later, and reduce the risk of overlooking a potential problem.

Once the System is installed, but before the finishes are applied, the membrane should be checked for damaged areas and repaired as necessary. Also joints and seals should be checked to make sure they are adequate. Any repairs found necessary should be carried out in accordance with Section 11 of this manual.

12.2 MAINTENANCE TO MECHANICAL PUMPS & DRAINAGE SYSTEM

The maintenance inspection should cover the following items plus any additional requirements as required by the specific pump manufacturer.

1. Cleaning and de-scaling of pumping system as required.
2. Checking for and ensuring free movement of the pump impeller.
3. Checking pump seals for leakage and renewing as required.
4. A pump impeller test ensuring free movement.
5. Inspect pump discharge pipes for damage and leaks.
6. Remove any debris from base of sump that may interfere with pumping.
7. Check electrical connections and fuses.
8. Flush through the Basedrain and Floordrain drainage system.

All the above should be carried out at least once per year as a minimum requirement by a competent person.

Note: Sump pumps are powered by electricity. It is important to maintain a constant power source to achieve maximum drainage capacity. Newton Power Converters are available for continuing the discharge of the sump during failure to the power supply.

12.3 ALTERATIONS

Newton Membranes, like other waterproofing membranes, should not be pierced in any way.

If works are proposed in the basement area that is likely to penetrate or disturb the membrane, advice must be sought from the specialist installing company or Newton Waterproofing, prior to such work being carried out.

Even if minor modifications are proposed to the waterproofed areas such as shelves, cupboards etc. the contractor who installed the system should be contacted so that they can advise on the correct fixing method.

SECTION 13. PRODUCT GUIDE

BASIC GUIDE FOR ESTIMATING MATERIAL REQUIREMENT FOR SYSTEM 500

	A	B	C	D
Product	Newton 508	Newton 520	Newton 508 Mesh & Newton 503 Mesh	Newton 503
Wall membrane	48m ² rolls Wall area ÷ 46 = N° of rolls 40m ² rolls Wall area ÷ 38 = N° of rolls	N/A	Wall area ÷ 38 = N° of rolls	Wall area ÷ 57 = N° of rolls
Floor membrane	48m ² rolls Floor area ÷ 46 = N° of rolls 40m ² rolls Floor area ÷ 38 = N° of rolls	Floor area ÷ 38 = N° of rolls	N/A	Wall area ÷ 57 = N° of rolls
Fixing plugs to wall membrane	Number of plugs to fix membrane to the wall relative to the wall finish	N/A	500 plugs per roll of wall membrane	Number of plugs to fix membrane to the wall relative to the wall finish
Newton Waterseal Tape (22.5m roll)	1 roll of tape for each roll of membrane			
Newton Waterseal Rope (4.75m roll)	1 roll per roll of Newton 500 for 'stud over stud' joints	N/A	1 roll per roll of Newton 500 for 'stud over stud' joints	N/A
Newton Overtape (20m roll)	1 roll per 20m of perimeter. 1 roll per 3 rolls of wall membrane for repairs	Newton 520 1 roll per roll of membrane plus 1 roll per 20m of perimeter	1 roll per 3 rolls of Newton 500 for repairs	1.7 rolls per roll of Newton 300 plus 1 roll per 20m of perimeter of area
Newton Basedrain (2m lengths)	Linear run of wall / floor junction ÷ 2 = N° of lengths			
Newton Floordrain (2m lengths)	Linear run of construction joints ÷ 2 = N° of lengths			
Newton Pump System	One Sump for every 25m of Basedrain in each direction. This rule of thumb should be modified to take into account the water-tightness of the structure and/or the likelihood of greater than normal water ingress, for example in flat ground of permeable soils			

SECTION 14. APPENDICES - TECHNICAL DRAWINGS (14 NO.)

JN5010

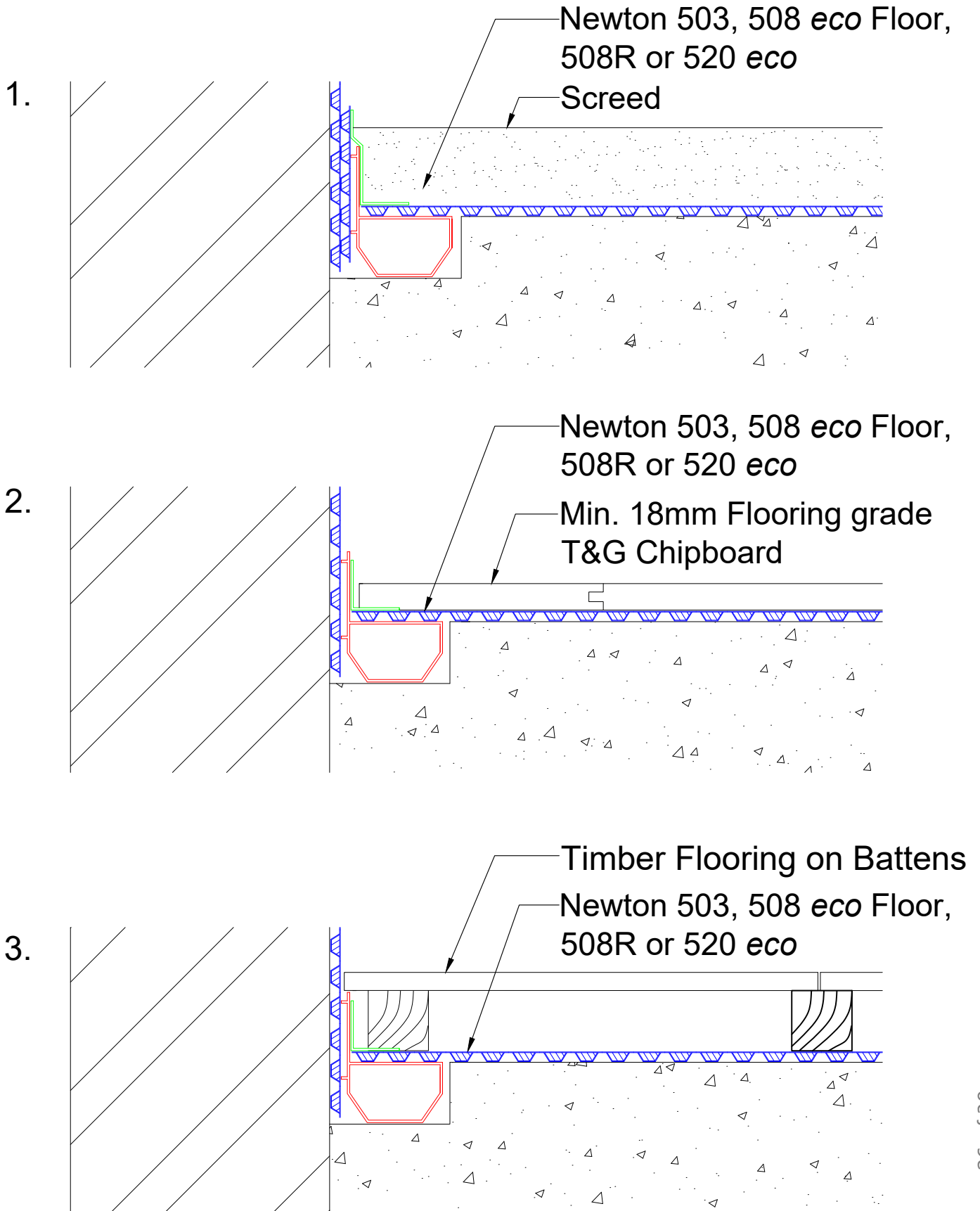

NEWTON CDM - CAVITY DRAIN WATERPROOFING SYSTEM

JN5011

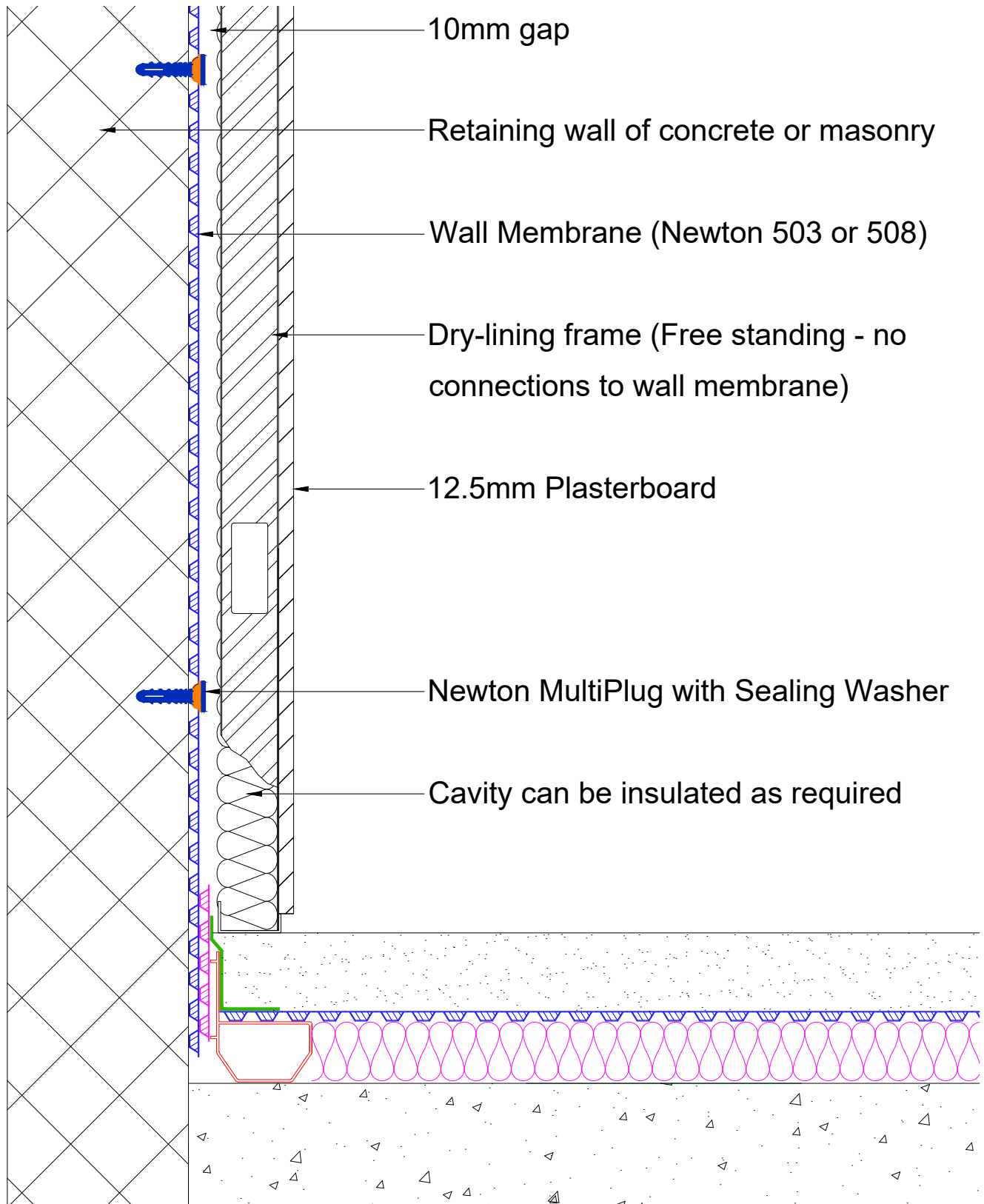

JN5012

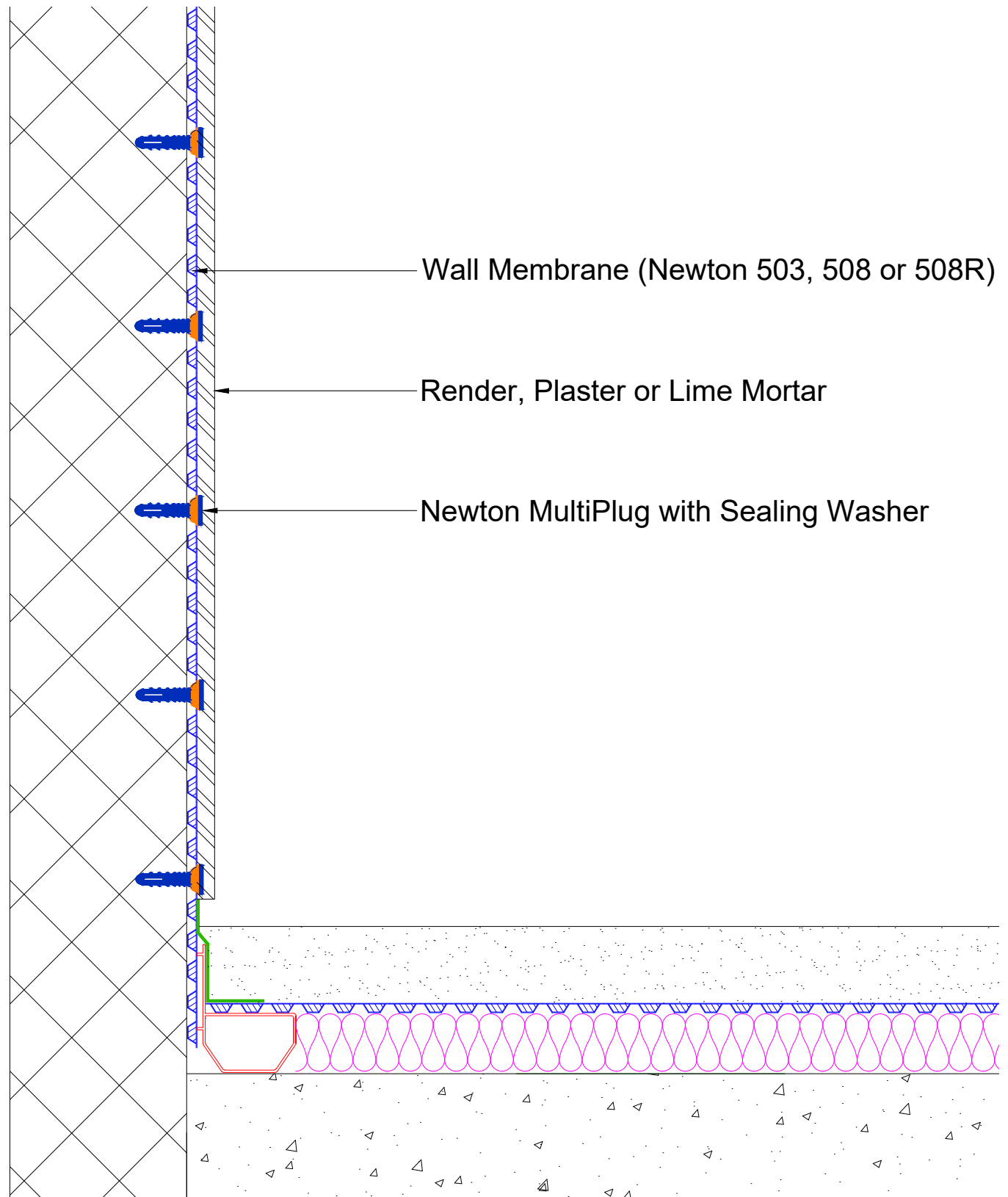

NEWTON CDM - CAVITY DRAIN WATERPROOFING SYSTEM

JN5014

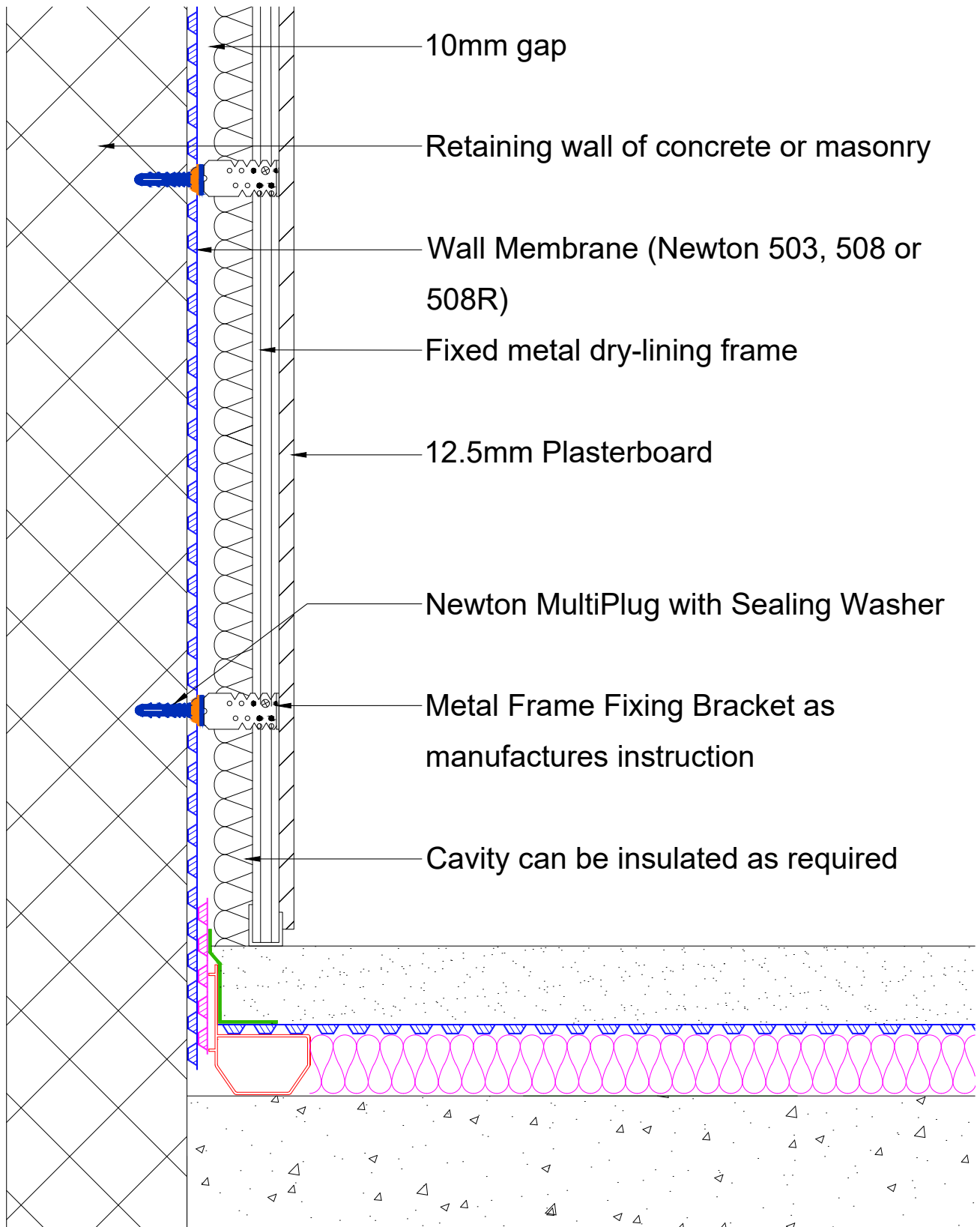

JN5015

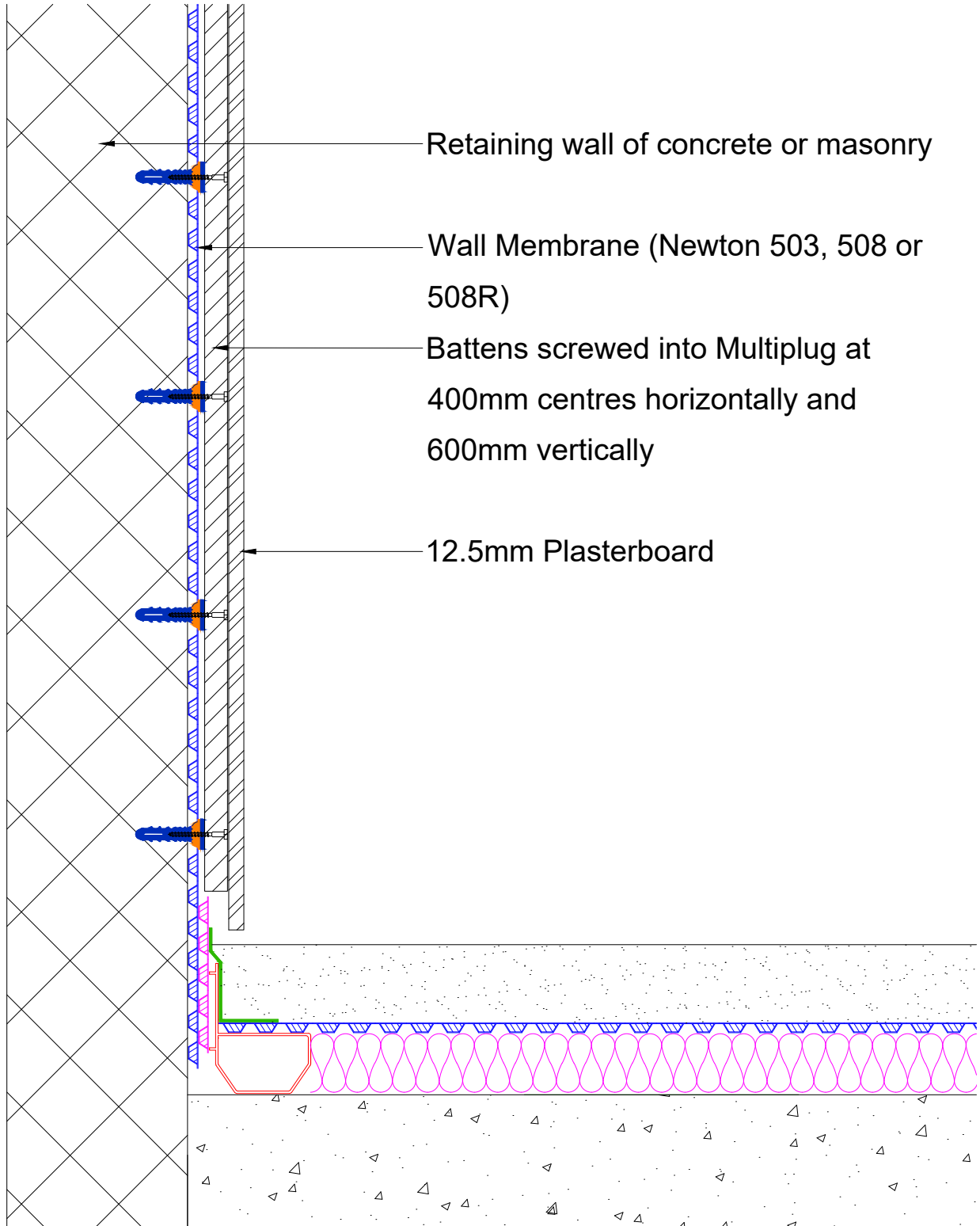

JN5016

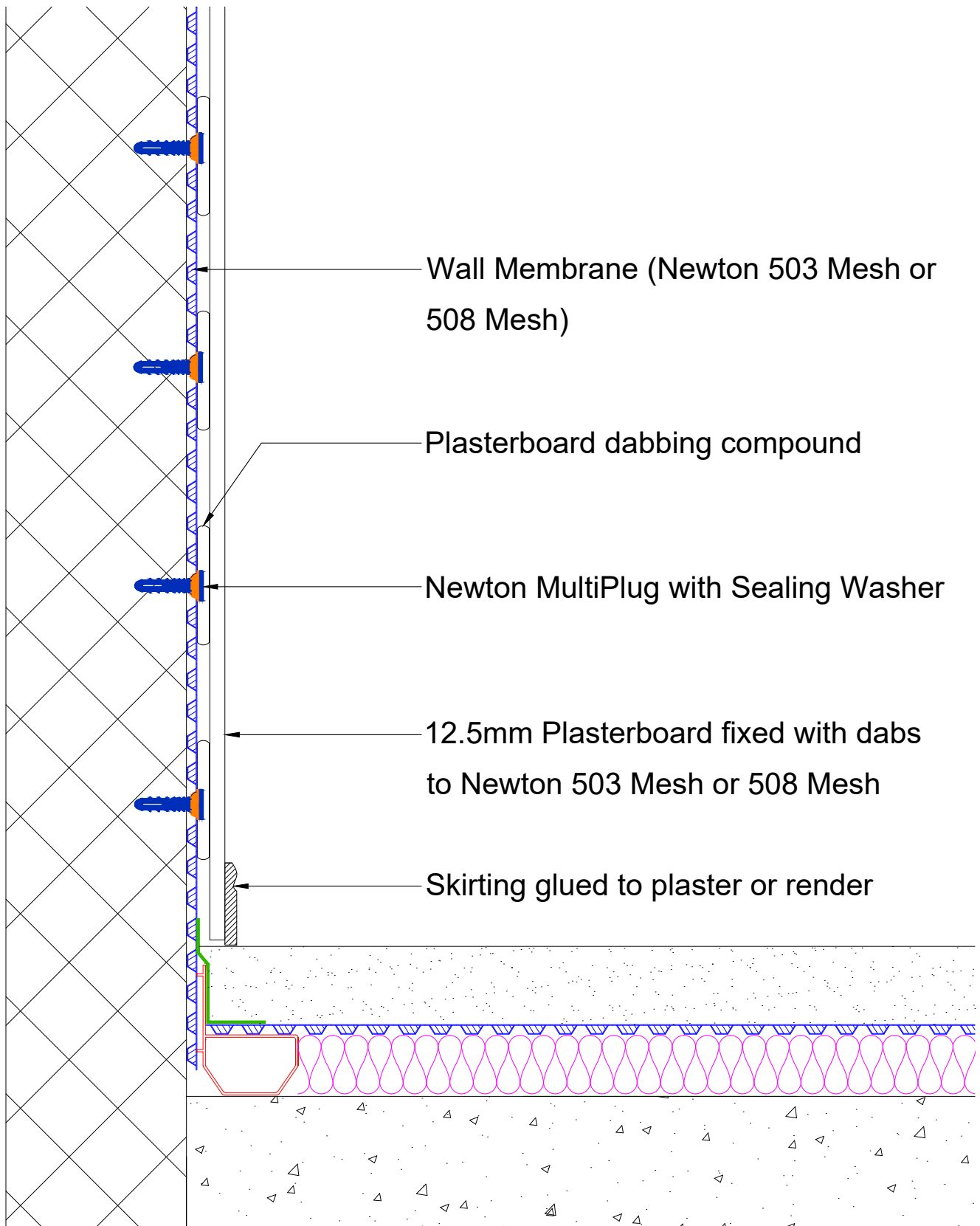

JN5017

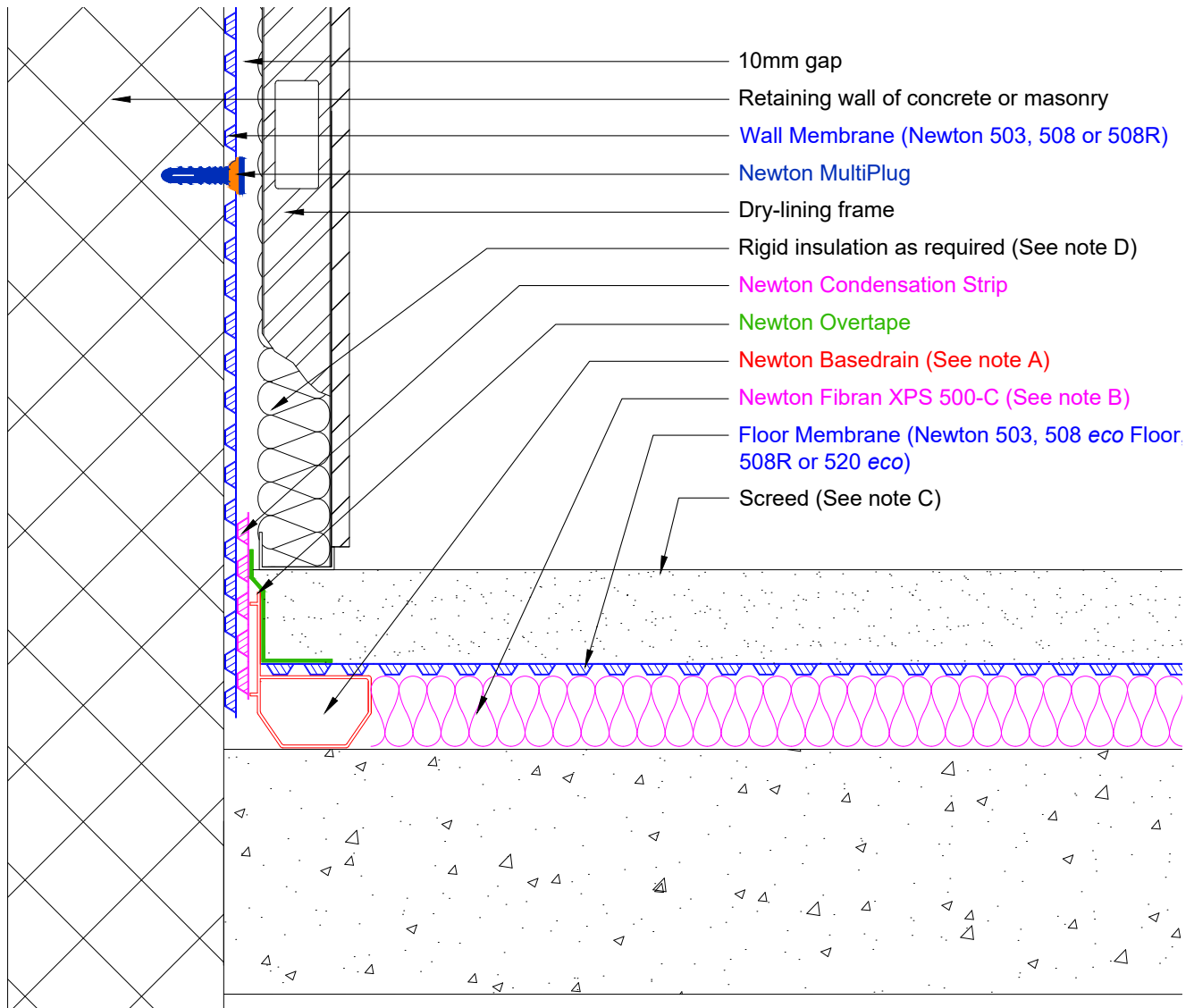

This detail assumes that the slab is in good condition - constructed to BS EN 1992 (Eurocode 2), and that the structure as a whole is of sufficient mass and quality to resist heads of water pressure as required by BS8102.

It is recommended that the concrete be treated with Newton 906 Lime Inhibitor to limit the leaching of free lime from the concrete.

All construction joints (day joints, shrinkage joints, movement joints etc) should be waterproofed with Newton System 300 waterbars to limit water ingress thorough joints in the structure.

A) Newton Basedrain should always be laid level and connected to the sump chamber or safe gravity drainage with at least two Drainage Connectors, see drawings CDM-P03 (Basedrain Layout & Parts) and CDM-P09 (Titan-Pro Pump System). Construction joints to the floor should be protected by Newton Floordrain, see drawing CDM-D01 (Construction joints protected by Newton Floordrain). For supporting walls detailing please see drawing CDM-D03.

B) Newton Fibran XPS 500-C is placed below the Newton flooring membrane as a fully drained supporting spacer. The maximum floor load is 16 Mpa (1.6 tonnes/m²). Newton Fibran XPS 500-C has a thermal conductivity of 0.035W/mk and as such will make a significant contribution to the U-value of the floor.

C) Screed to manufacturers recommendations or current British Standard.

D) If insulating in front of the wall membrane a vapour control layer may be required to prevent interstitial condensation, see Guidance Note GD-01.

JN5018

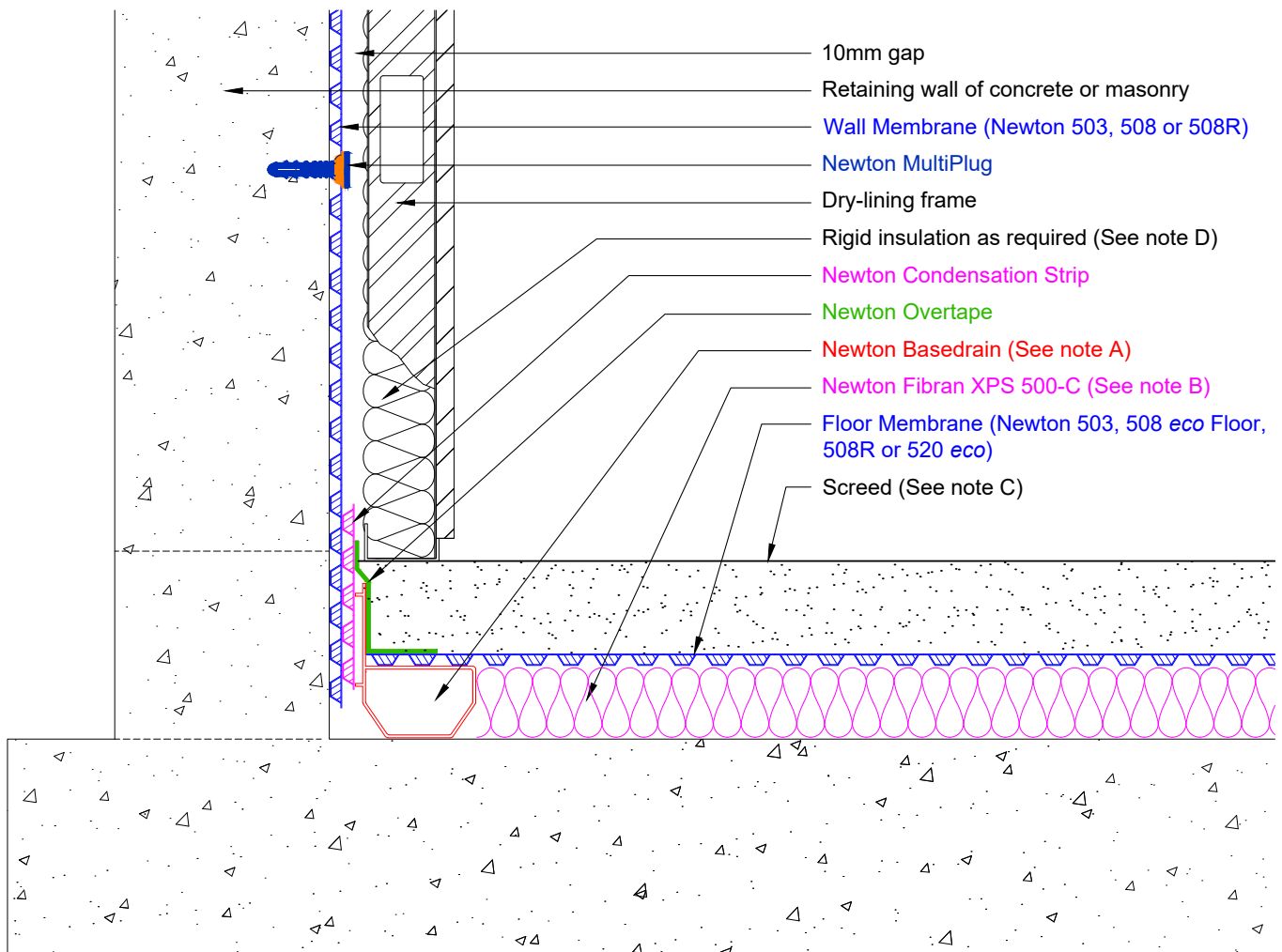

This detail assumes that the raft is in good condition - constructed to BS EN 1992 (Eurocode 2), and that the structure as a whole is of sufficient mass and quality to resist heads of water pressure as required by BS8102.

It is recommended that the concrete be treated with Newton 906 Lime Inhibitor to limit the leaching of free lime from the concrete.

All construction joints (day joints, shrinkage joints, movement joints etc) should be waterproofed with Newton System 300 waterbars to limit water ingress thorough joints in the structure.

A) Newton Basedrain should always be laid level and connected to the sump chamber or safe gravity drainage with at least two Drainage Connectors, see drawings CDM-P03 (Basedrain Layout & Parts) and CDM-P09 (Titan-Pro Pump System). Construction joints to the floor should be protected by Newton Floordrain, see drawing CDM-D01 (Construction joints protected by Newton Floordrain). For supporting walls detailing please see drawing CDM-D03.

B) Newton Fibran XPS 500-C is placed below the Newton flooring membrane as a fully drained supporting spacer. The maximum floor load is 16 Mpa (1.6 tonnes/m²). Newton Fibran XPS 500-C has a thermal conductivity of 0.035W/mk and as such will make a significant contribution to the U-value of the floor.

C) Screed to manufacturers recommendations or current British Standard.

D) If insulating in front of the wall membrane a vapour control layer may be required to prevent interstitial condensation, see Guidance Note GD-01.

JN5019

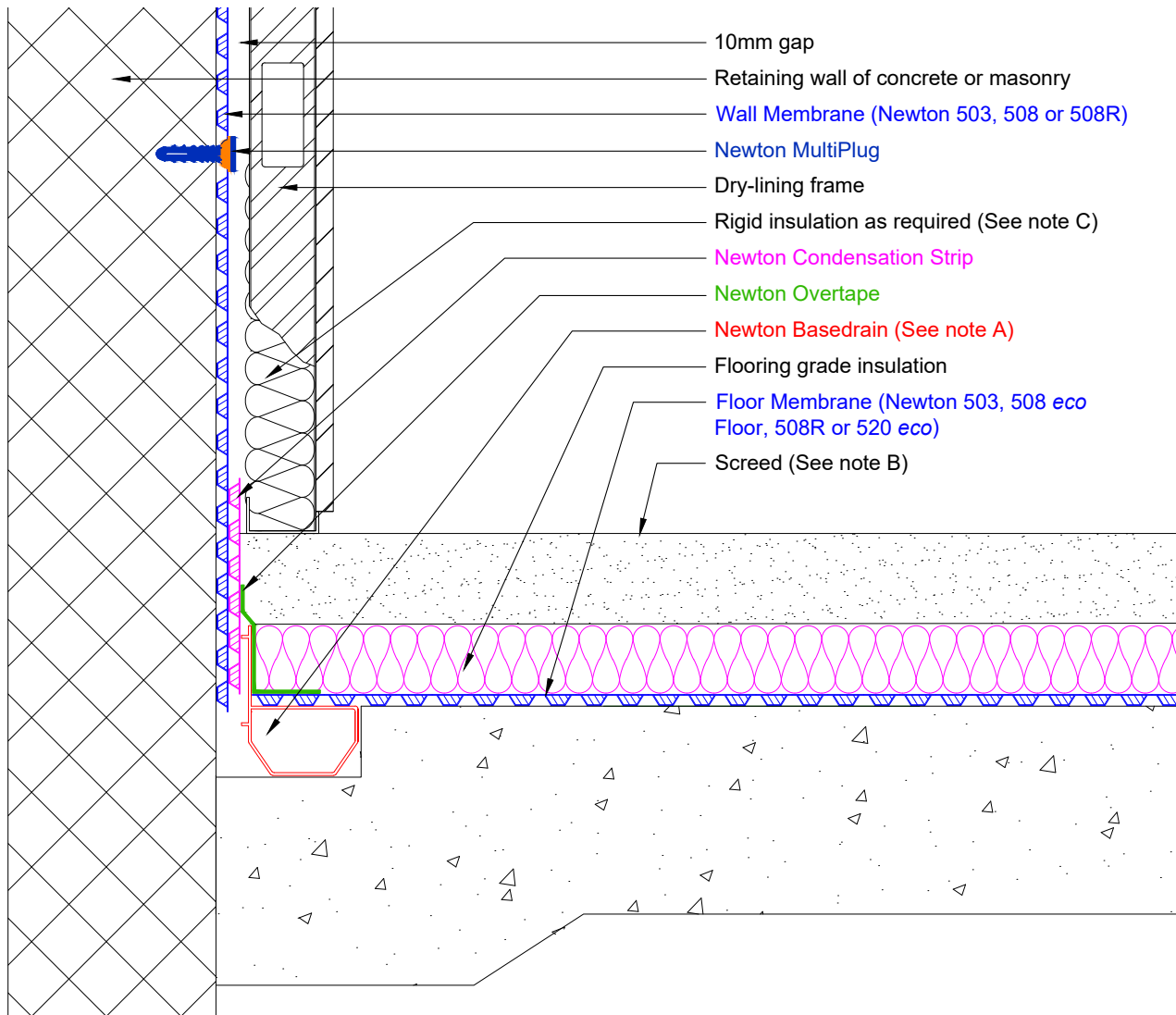

This detail assumes that the slab is in good condition -constructed to BS EN 1992 (Eurocode 2), and that the structure as a whole is of sufficient mass and quality to resist heads of water pressure as required by BS8102.

It is recommended that the concrete be treated with Newton 906 Lime Inhibitor to limit the leaching of free lime from the concrete.

The slab reinforcing steel will need to be designed to accommodate the recess for the Newton Basedrain drainage channel to ensure correct coverage of concrete above the steel.

All construction joints (day joints, shrinkage joints, movement joints etc) should be waterproofed with Newton System 300 waterbars to limit water ingress thorough joints in the structure.

A) Newton Basedrain should always be laid level and connected to the sump chamber or safe gravity drainage with at least two Drainage Connectors, see drawings CDM-P03 (Basedrain Layout & Parts) and CDM-P09 (Titan-Pro Pump System). Construction joints to the floor should be protected by Newton Floordrain, see drawing CDM-D02 (Construction joints protected by Newton Floordrain). For supporting walls detailing please see drawing CDM-D04.

B) Screed to manufacturers recommendations or current British Standard.

C) If insulating in front of the wall membrane a vapour control layer may be required to prevent interstitial condensation, see Guidance Note GD-01.

JN5021

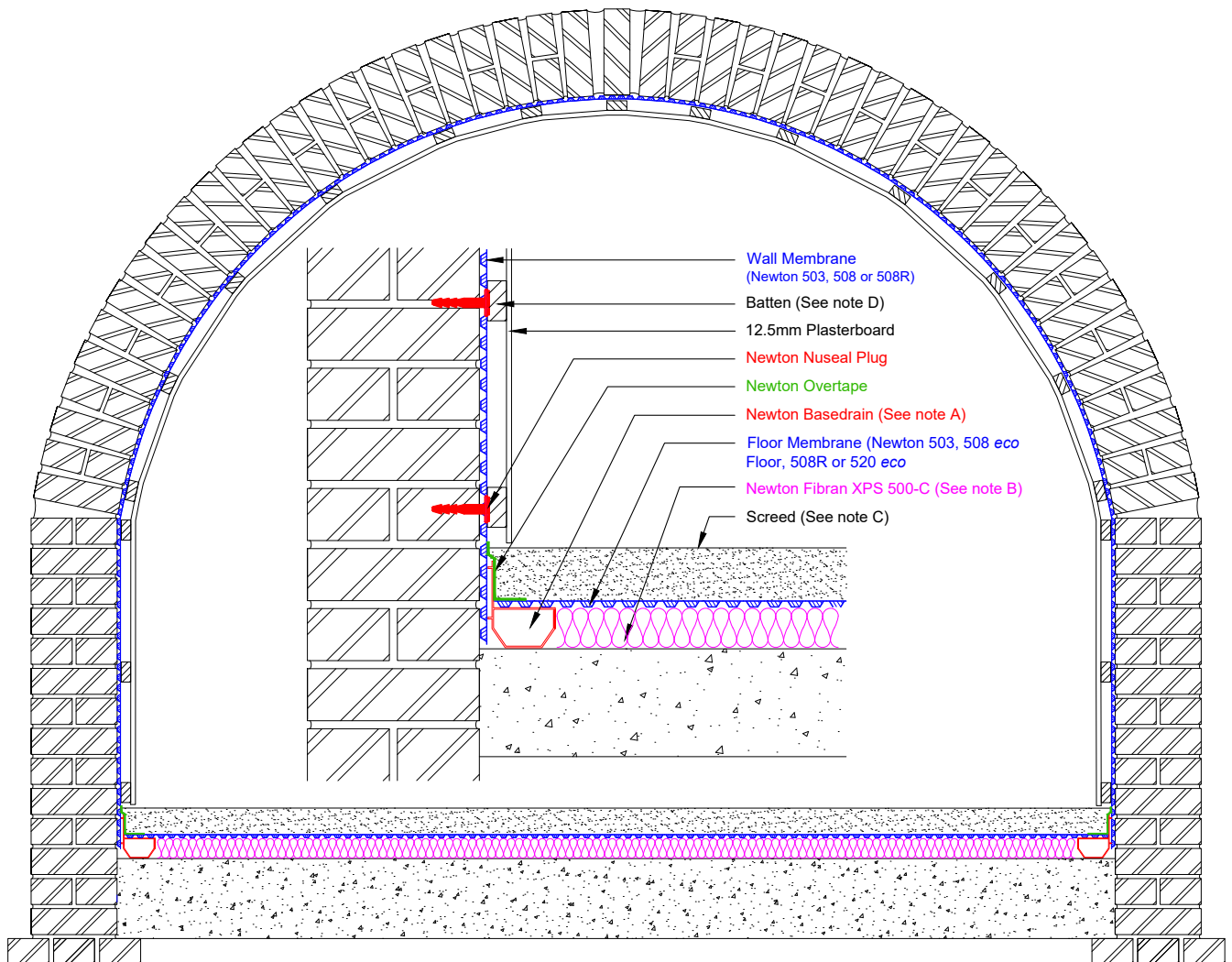

This detail assumes that the slab is in good - constructed to BS EN 1992 (Eurocode 2), and that the structure as a whole is of sufficient mass and quality to resist heads of water pressure as required by BS8102.

It is recommended that the slab be treated with Newton 906 Lime Inhibitor prior to installation of the Newton System to limit the leaching of free lime from the concrete.

A) Newton Basedrain should always be laid level and connected to the sump chamber or safe gravity drainage with at least two Drainage Connectors, see drawings CDM-P03 (Basedrain Layout & Parts) and CDM-P09 (Titan-Pro Pump System). Construction joints to the floor should be protected by Newton Floordrain, see drawing CDM-D01 (Construction joints protected by Newton Floordrain). For supporting walls detailing please see drawing CDM-D03.

B) Newton Fibran XPS 500-C is placed below the Newton flooring membrane as a fully drained supporting spacer. The maximum floor load is 16 Mpa (1.6 tonnes/m²). Newton Fibran XPS 500-C has a thermal conductivity of 0.035W/mk and as such will make a significant contribution to the U-value of the floor.

C) Screed to manufacturers recommendations or current British Standard.

D) If insulating in front of the wall membrane a vapour control layer may be required to prevent interstitial condensation, see Guidance Note GD-01.

JN5022

Joint Sealing details - Newton 508, 508R, 508 eco & 508 Mesh

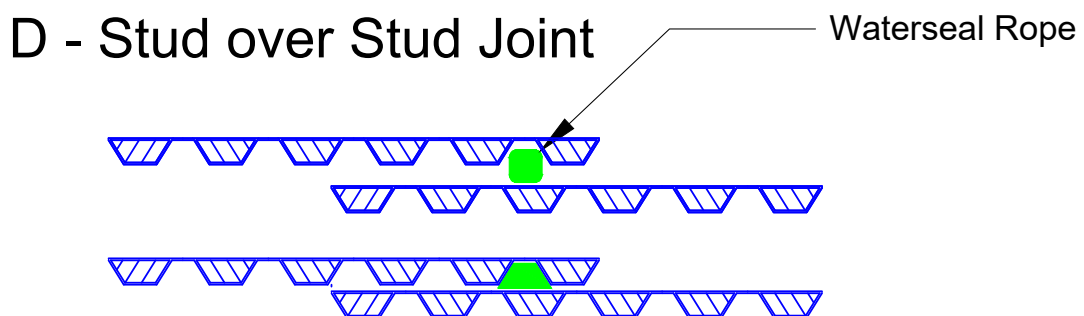
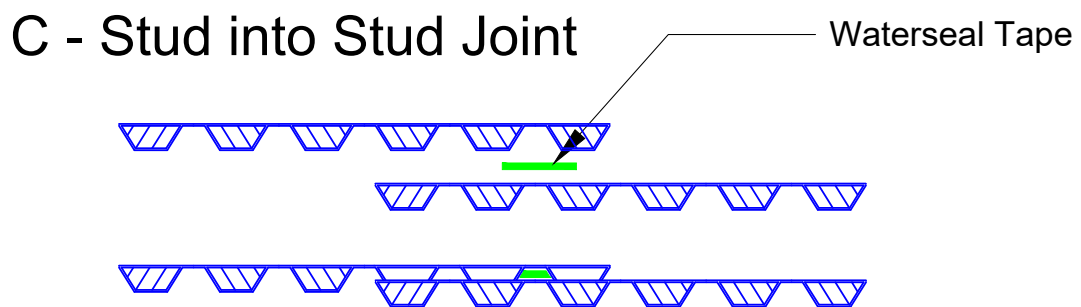
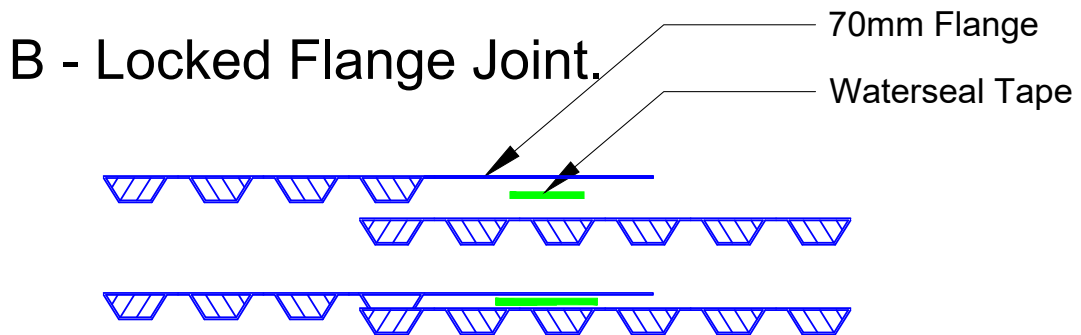
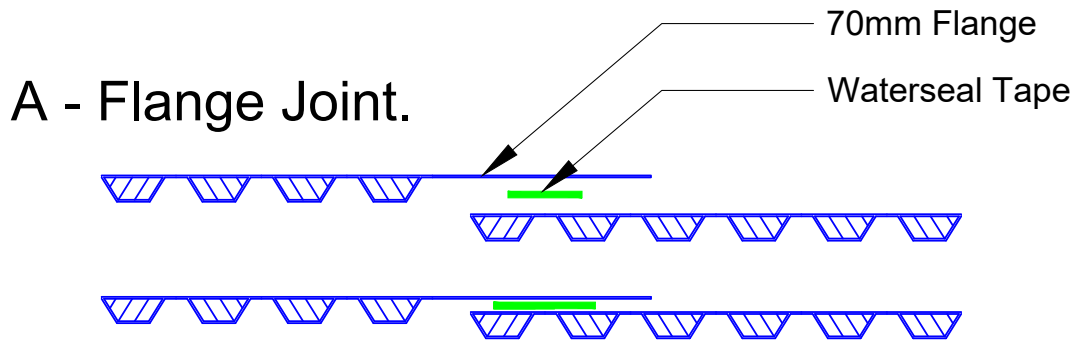

JN5023

Joint Sealing details - Newton 503 & 520 eco

A - Newton 503 Butt Joint

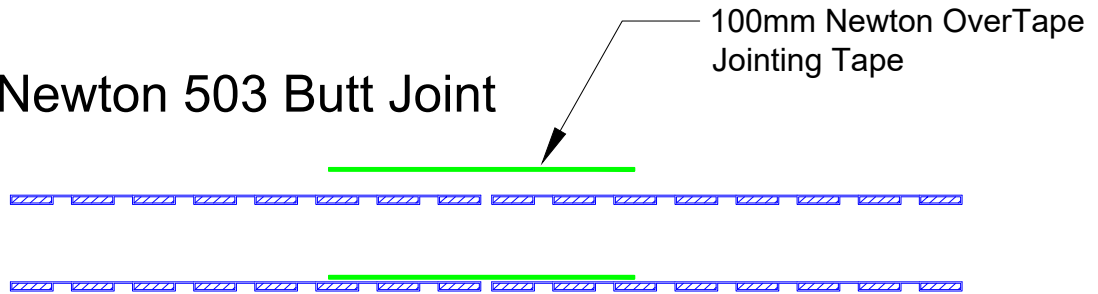

B - Newton 520 Flange Joint

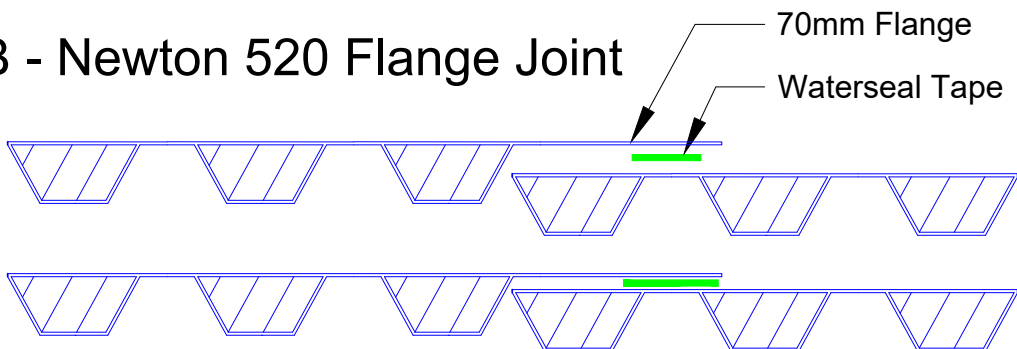

C - Newton 520 Butt Joint

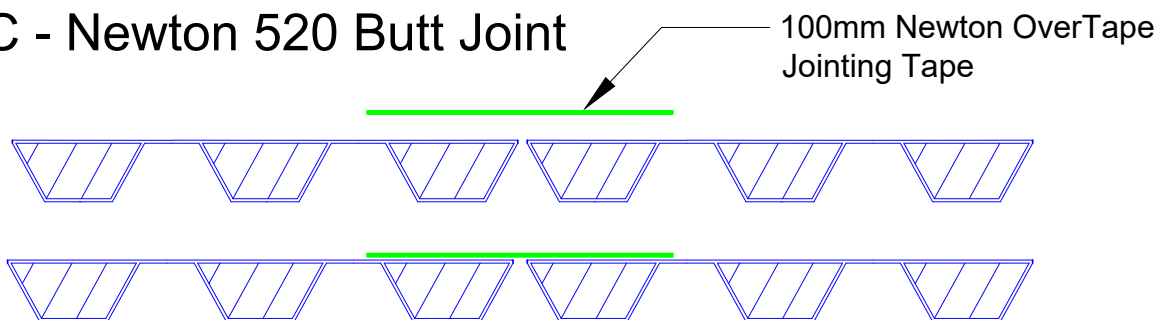

JN5024

Sealing details - Protrusions through Newton Membranes

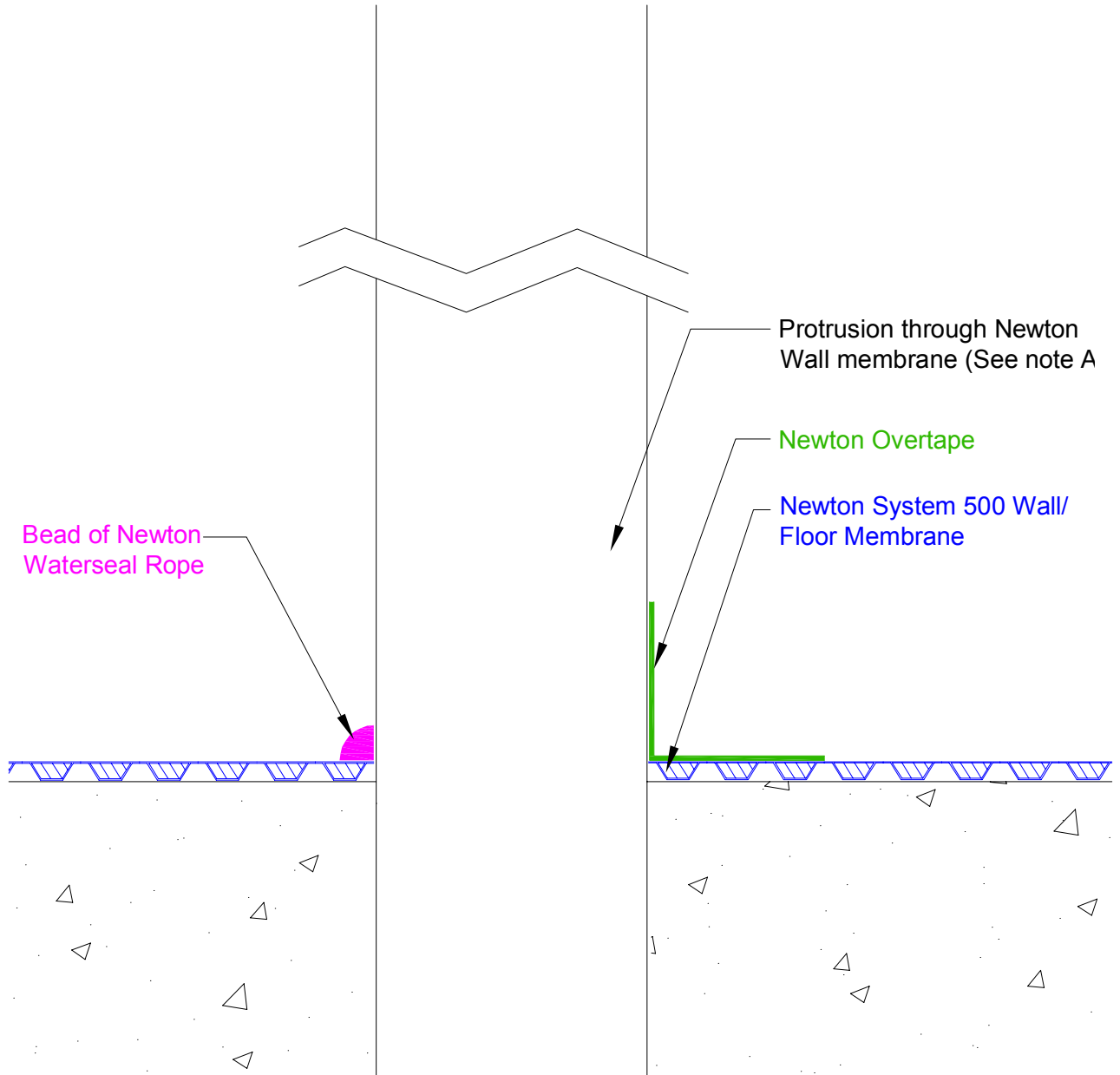

This detail shows a protrusion, such as a pipe or steel, through the Newton System 500 Wall/Floor membrane, showing sealing with Newton Waterseal Rope or Newton Overtape as options. This detail should be used in conjunction with Newton System 500 drawings prefixed RA or SA.

A) The protrusion may need priming with a primer such as Newton 109-LM to ensure adhesion of the sealing product to the protrusion.

JN5028

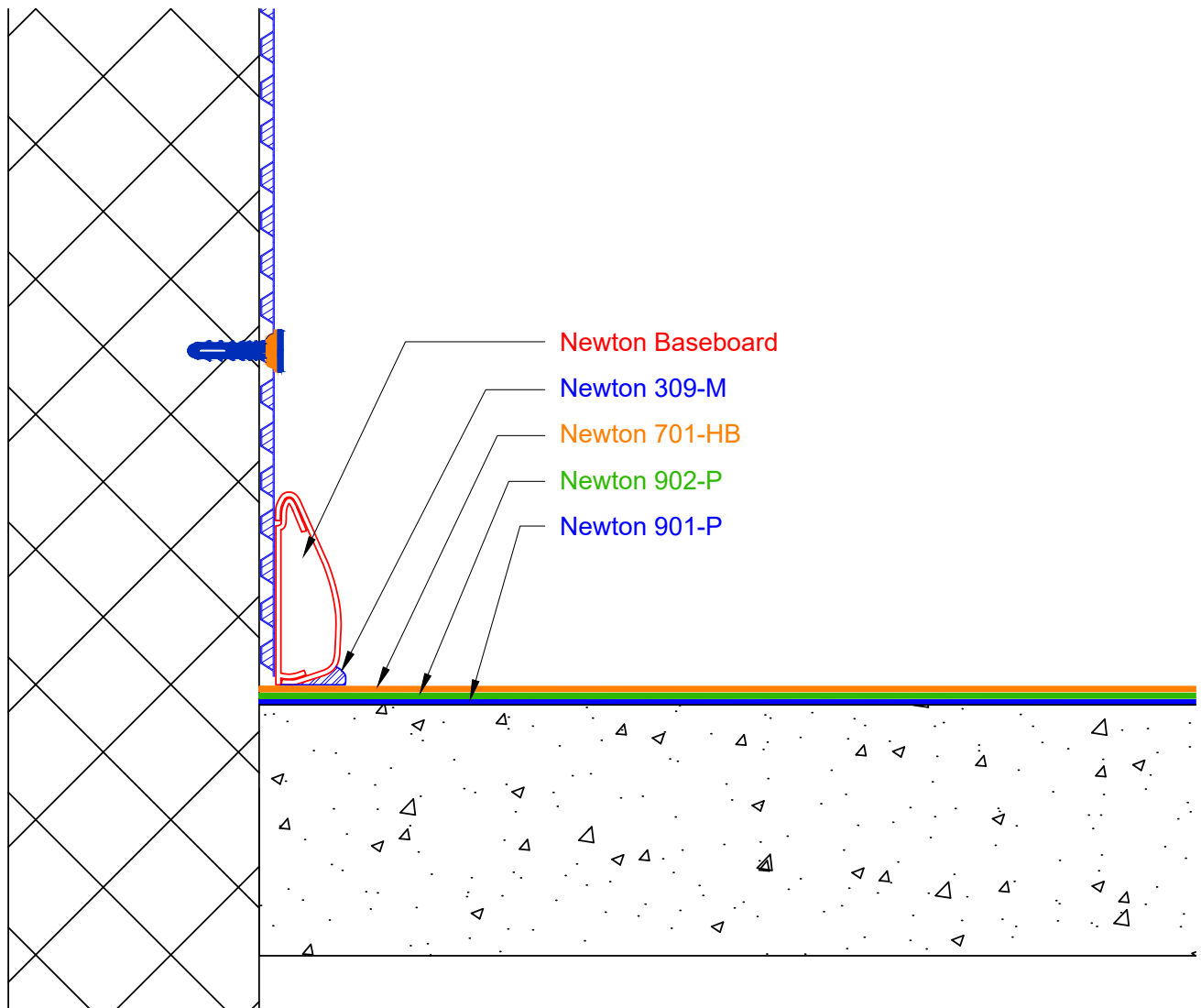

This detail assumes that the slab is in good condition - constructed to BS EN 1992 (Eurocode 2), and that the structure as a whole is of sufficient mass and quality to resist heads of water pressure as required by BS8102.

This drawing shows Newton Baseboard applied to a concrete slab to collect water ingressing at the wall/floor junction. The water is diverted by the Baseboard to a pumping system. Newton Baseboard should always be laid level and connected to the sump chamber or safe gravity drainage with at least two Drainage Connectors.

Newton 901-P and Newton 902-P primers provide a clean surface for the adhesion of the Baseboard.

Newton 309-M is an MS-polymer based, durable and fast curing elastic adhesive.

Newton 701-HB is a two component solvent free epoxy resin based floor coating developed to provide a protective and decorate properties.

This specification may be suitable for Grade 3 environment as defined by the habitable grade table within BS8102:2009.

It is recommended that concrete walls include a pore-blocking additive or be treated with Newton 106 Lime Inhibitor to limit the leaching of free-lime from the concrete. Do not apply to the concrete floor.