

A close-up photograph of a white, curved grille for an extract fan. The grille consists of multiple horizontal slats. In the center, a white cylindrical component is visible, which is part of the fan's internal mechanism. A purple semi-circular graphic is overlaid on the top right, and a blue semi-circular graphic is overlaid on the bottom left.

EXTRACT FANS

CREATING
A HEALTHY
INDOOR
ENVIRONMENT

NUAIRE'S PEDIGREE

Proud to Build British

Nuaire is a world leader in the design and manufacture of fans and ventilation systems. We put our energy into efficient ventilation so you don't waste yours.

Nuaire is a privately owned, British company that designs and manufactures innovative ventilation products for the residential and commercial sectors. We are proud to be recognised for our expertise, commitment to innovation and the outstanding quality of our products and customer service.

People are the heart of Nuaire, and we have over 400 staff at our headquarters with a further 65 technical sales engineers throughout the UK and Ireland.



MADE IN GREAT BRITAIN



Based in South Wales, our factory covers 18,000m², allowing us to manufacture almost all of our products on site; from small bathroom fans to large air handling units.

In recent years Nuaire has invested millions of pounds into new manufacturing plant to support its plans for growth.



"Our manufacturing facility is approximately 4 x the size of the Wembley pitch"



Nuaire's technical application team can offer expert advice and support to help you make the right choice in your ventilation strategy. Providing a simple, quick selection or offering advice on compliance with the very latest building regulations and environmental issues, we are here for you every step of the way.

GETTING IT
RIGHT FROM
THE START

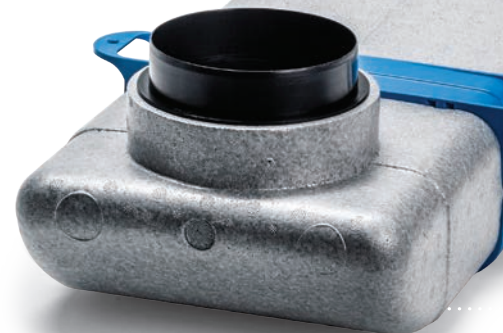



Advice On Compliance and SAP Q

Stay ahead of the latest building regulations and make the best product and fabric choices.

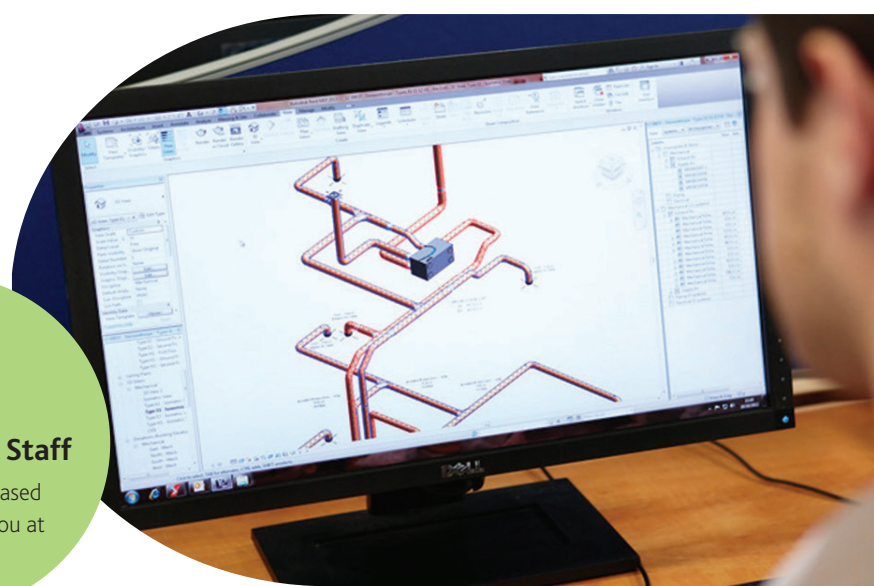

Over 65 Sales Staff

Field and office based staff to support you at every stage.



Gold Star Aftercare

Our comprehensive product warranty and dedicated after sales support gives you peace of mind.



Nuaire Academy

To ensure your installers get the best from your system and meet Building Regs, Nuaire offers BPEC training. This is free of charge to our customers delivered from our BPEC Accredited Training Centre.



The Full Service

Help with product selection, detailed parts lists and fast delivery ensure you meet your deadline and budget.



INTERMITTENT EXTRACT FANS (System 1) AND CONTINUOUS EXTRACT FANS (System 3)

A common, cost effective way to ventilate houses is extract fans. With a fan per 'wet room' (bathroom, en-suite, kitchen and utility room), extract fans can be either intermittent or continuously running.

Approved Document 'F' offers ventilation rates and guidance on fan install.

Extract + dMEV How do they work?



PROVIDES RAPID VENTILATION TO 'WET ROOMS'

Extract fans are fitted to a property's 'wet rooms' to provide rapid extraction of moisture and other pollutants. They operate intermittently either through automatic, or occupant control, with replacement fresh air provided through background ventilators.

dMEV

Nuaire's range of fans offer extremely low noise levels, have high efficiency EC/DC motors and are IPX4 rated.

Continuous running fans are set to provide background ventilation at a low rate. Nuaire's dMEV, measuring no more than a mini tablet device, is sleek and modern to discretely fit into wet rooms.

Typically costing less than £1 a year to run, it fully complies with regulation and comes with a 5 year warranty.



Install Options

Typical dMEV installation with fan mounted through ceiling.

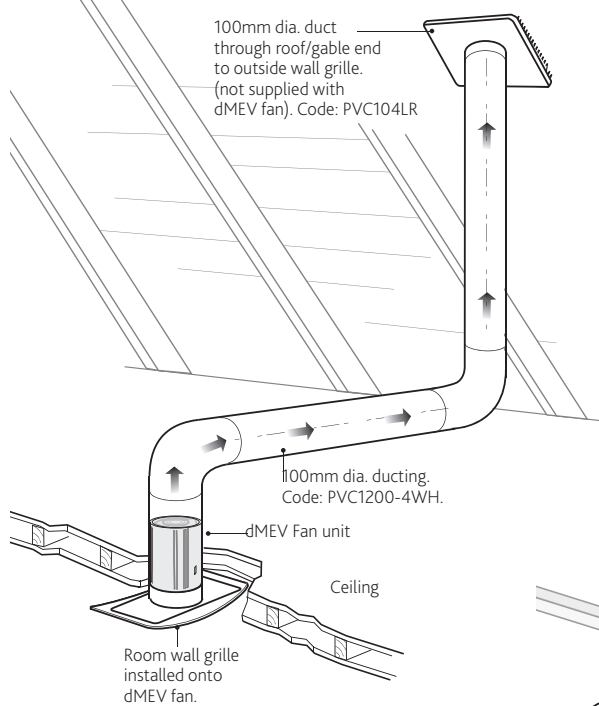

Typical dMEV installation with fan mounted through wall.

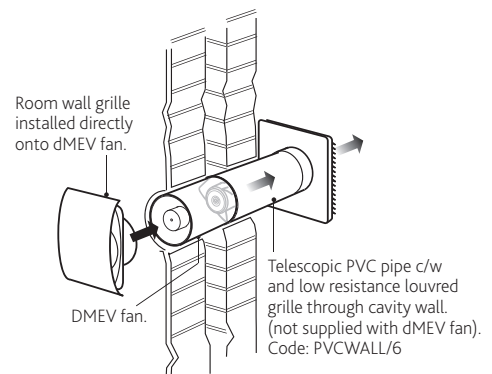

Typical dMEV induct/inline installation.

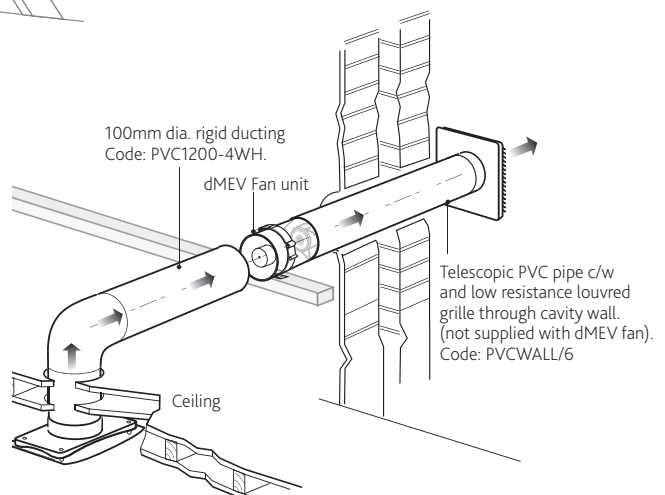

Building Regulations Part F

Room	Intermittent Extract	Continuous Extract	
	Minimum Rate	Minimum High Rate	Minimum Low Rate
Kitchen	30 l/s adjacent to hob, or 60 l/s elsewhere	13 l/s	Total extract rate should be at least the whole dwelling ventilation rate given in Table 5.1b
Utility Room	30 l/s	8 l/s	
Bathroom	15 l/s	8 l/s	
Sanitary Accommodation	6 l/s	6 l/s	

	Number of bedrooms in dwelling				
	1	2	3	4	5
Whole dwelling ventilation rate ^{a,b} (l/s)	13	17	21	25	29

Notes:

a. In addition, the minimum ventilation rates should be no less than 0.3 l/s per m² of internal floor area (this includes all floors, e.g. for a two-storey building, add the ground and first floor areas).

b. This is based on two occupants in the main bedroom and a single occupant in all other bedrooms. This should be used as the default value. If a greater level of occupancy is expected, add 4 l/s per occupant.

Intermittent extract fans

Intermittent extract rates are given in Table 5.1a. For sanitary accommodation only, as an alternative the purge ventilation provisions (windows) given in appendix b can be used where security is not an issue.

Instead of a conventional intermittent fan, a continuously running single room heat recovery ventilator could be used in wet rooms. It should use the minimum high rate given in Table 5.1a and 50% of this value is the minimum low rate. No background ventilator is required in the same room as the single room heat recovery ventilator. Furthermore, the total equivalent background ventilator area described in the tables below can be reduced by 2500mm² for each room containing a single room heat recovery ventilator.

Location of intermittent extract fans

Intermittent extract fans should be installed in each wet room.

Cooker hoods should be 650mm to 750mm above the hob surface (or follow manufacturer instructions).

Intermittent extract fans other than cooker hoods should be installed as high as is practical and preferably less than 400mm below the ceiling.

Where fans and background ventilators are fitted in the same room they should be a minimum of 0.5m apart.

Controls for Intermittent Extract

May be operated manually and/or automatically by a sensor (e.g. humidity, occupancy/usage, pollutant release). Humidity controls should not be used for sanitary accommodation as odour is the main pollutant.

In kitchens, any automatic control must provide sufficient flow during cooking with fossil fuel (e.g. gas) to avoid build up of combustion products.

Any automatic control should have a manual override to allow the occupant to turn the extract on.

In a room with no openable window (i.e. an internal room) an intermittent extract fan should have a 15 minute overrun. In rooms with no natural light, the fans could be controlled by the operation of the main room light switch.

Manual controls

Where manual controls are provided, they should be within reasonable reach of the occupants. It is recommended that they are located in accordance with the guidance for Requirement N3 safe opening and closing of windows etc, which is given in Approved Document N. Where reasonable, pull cords, operating rods or similar devices should be provided. Although Requirement N3 applies only to work places, for the purpose of Approved Document F it should also apply to dwellings.

Noise

Fans should be quiet so as to not discourage their use by the occupants.

Extract Fan Product Selector

PAGE No.	8		11		14
	SINGLE SPEED		TWIN SPEED		CONTINUOUS
Feature	NA100	NA150	NA100X	NA150X	dMEV
Part F Building Regulations Compliant					
IPX4 Splash proof for installation in zones 1 & 2					
Quiet running					
Wall mounted					
Ceiling mounted					
Panel mounted					
Window mounted					
1 year warranty					
5 year warranty					
Easy maintenance					
Suitable for WC/Bathroom					
Suitable for kitchen/utility					



NUAIRE'S EXTRACT FANS

230V & 12V Single Speed Fans

The Nuaire slimline range of axial fans incorporates 12 models complete with fixed back draft shutters.

The fans have been specifically designed to ventilate small rooms such as toilets, bathrooms, shower rooms, utility rooms and kitchens and are ideal for wall, ceiling or panel installation. The units extract directly to outside or through a short length of ducting.



Mounting Options

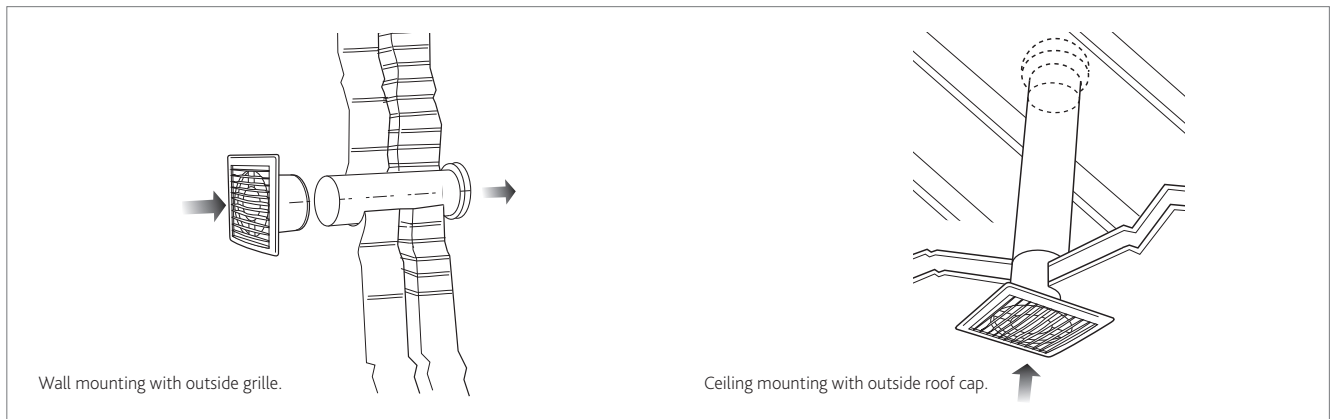

230V & 12V Twin Speed Fans

The Nuaire range of SELV and 2 speed axial fans incorporates 3 models.

They are ideal for ventilating small rooms such as toilets, bathrooms, cloakrooms and kitchens etc and can be installed on wall, ceiling, panel or window.

Window Kit Code: NA 100-WK



Mounting Options

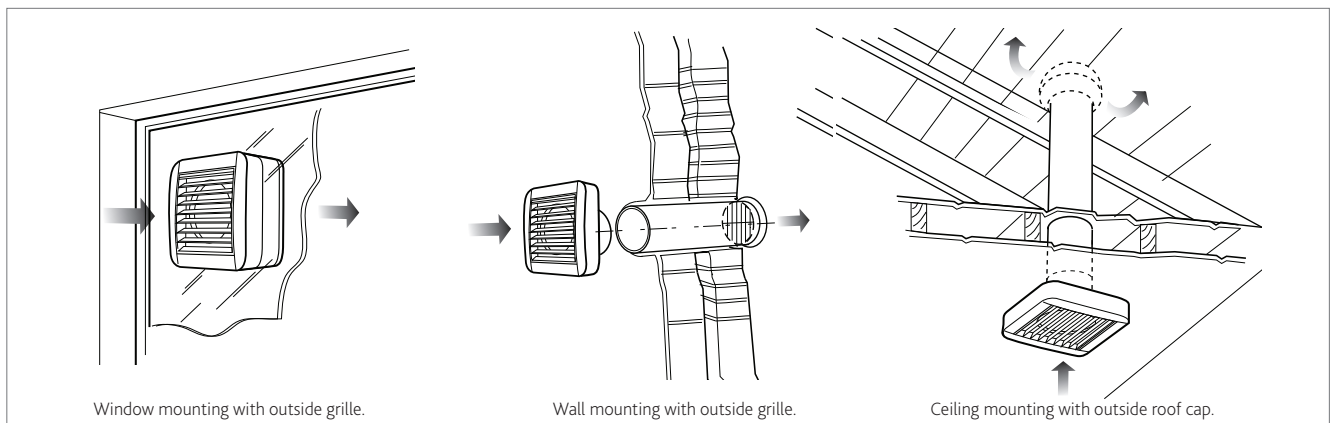

Performance - Single Speed

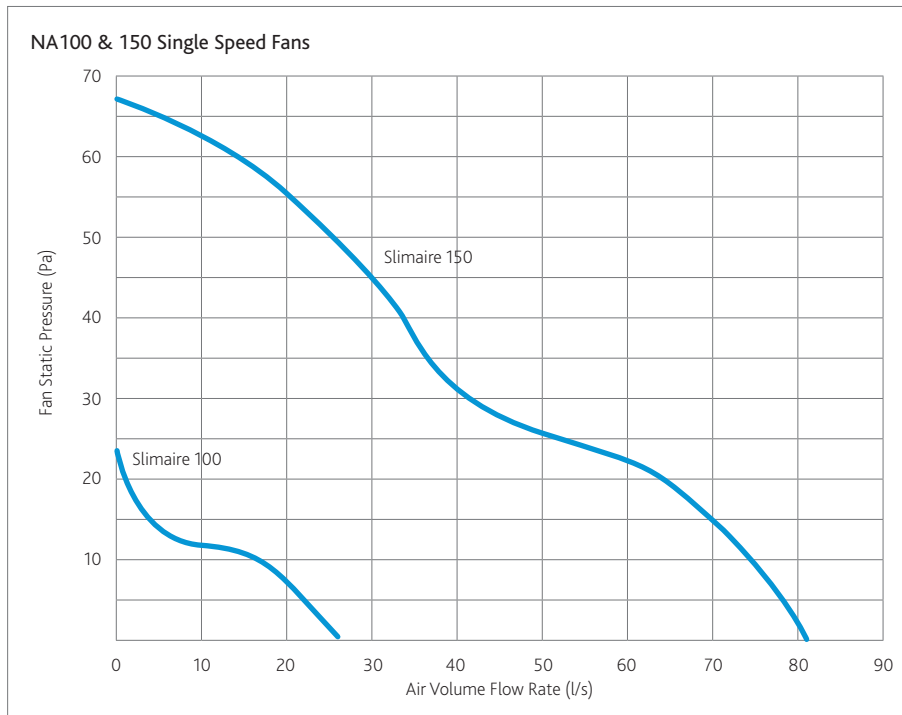

Control Function

Code	dBa @3m	Operating voltage	Control function
NA100/150	40/49	230	Standard version operated by remote switch.
NA100PC/150PC	40/49	230	Standard version operated by pull cord.
NA100T/150T	40/49	230	With integral overrun timer - the fan should be operated by a remote switch which can also serve to switch the room light on and off. After the light is switched off, the fan will continue to operate for a minimum of 3 minutes (adjustable to a maximum of 25 minutes) by turning the trimmer in a clockwise direction.
NA100HT/150HT	40/49	230	With integral humidistat and overrun timer - the adjustable, electronic humidistat is pre-set so that the fan will operate automatically when the moisture content in the room reaches a pre-set level of relative humidity. The fan will continue to run until the relative humidity falls below the pre-set level. This level can be adjusted by turning the trimmer on the fan. This fan can be operated by a remote switch or light switch allowing operation of the fan independently of the humidistat. The overrun timer, which will always make the fan continue to operate for the pre-set length of time even after it has been manually switched off, can be adjusted as described above.
NA100PIR/150PIR	40/49	230	With integral sensor and overrun timer - the fan will start to operate automatically when it detects the presence of a person. After the room is vacated, the fan will continue to operate for a minimum of 3 minutes (adjustable to a maximum of 25 minutes) by turning the trimmer in an anti-clockwise direction.
NA100-12	40	12	This version must be installed using the remote transformer supplied (see current IEE Regulations for guidance).
NA100T-12	40	12	With integral overrun timer adjusted as above. This version must be installed using the remote transformer supplied (see current IEE Regulations for guidance).

General Arrangement - Single Speed

DIMENSIONS (MM) & UNIT WEIGHT

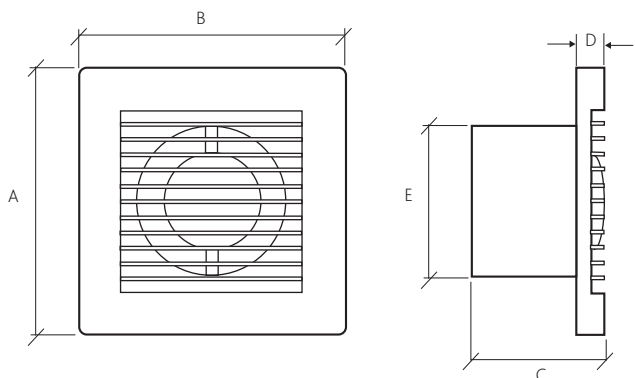

Unit	A	B	C	D	E dia.	Weight (Kg)
NA100	160	160	81	17	97	0.5
NA150	200	200	119	22	149	1.5

Wiring

NA100/150
with remote switch

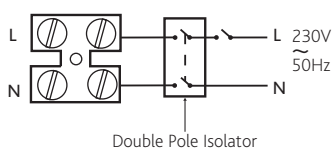

NA100PC/150PC
with pullcord

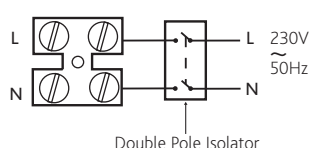

NA100T/150T
via light switch (or remote switch)

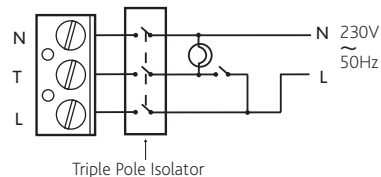

NA100/150HT PIR
with Humidistat and
Integral sensor.

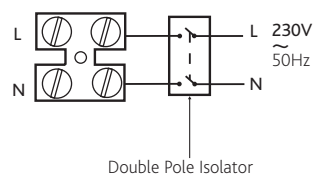

NA100-12, 12V
Must be installed with remote
transformer.

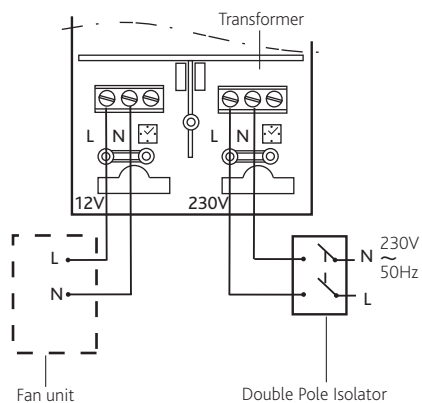

NA100T-12, 12V
via light switch (or remote switch)
Must be installed with remote transformer

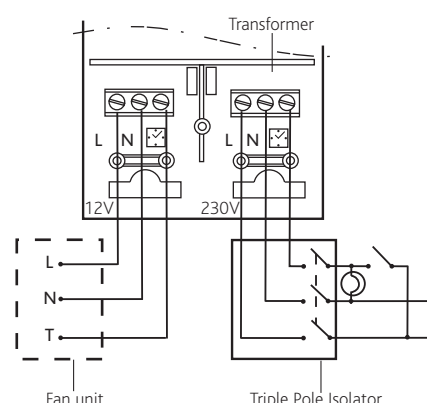

Performance - Twin Speed

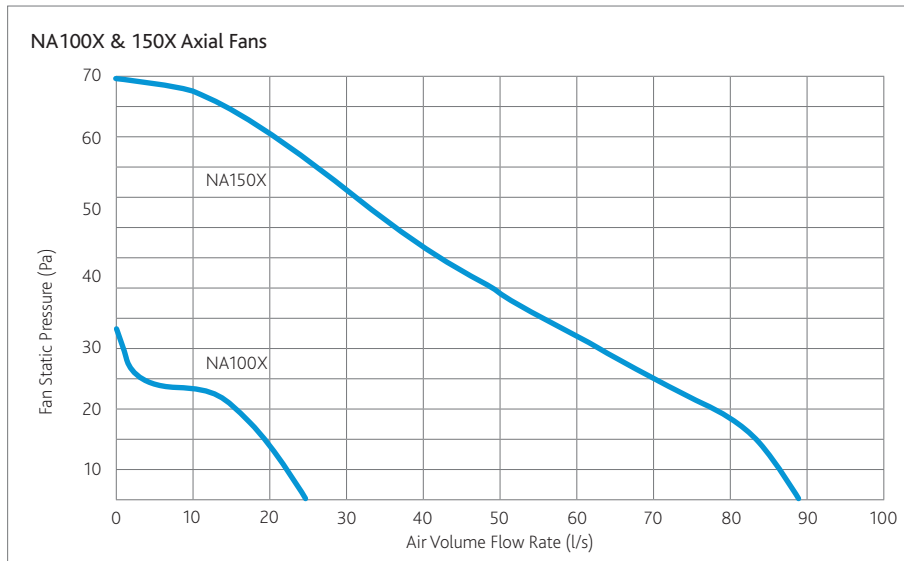

Control Function

Code	dB(A) @3m	Operating voltage	Control function
NA100XPC	39	230	Continuous low duty with boost facility operated by pull cord or remote switch.
NA100XP-12	39	12	Continuous low duty with boost facility operated by pull cord or remote switch, 12V SELV. This version must be installed using the remote transformer supplied (see current IEE Regulations for guidance).
NA150XPC	49	230	Continuous low duty with boost facility operated by pull cord or remote switch.

General Arrangement - Twin Speed

DIMENSIONS (MM) & UNIT WEIGHT

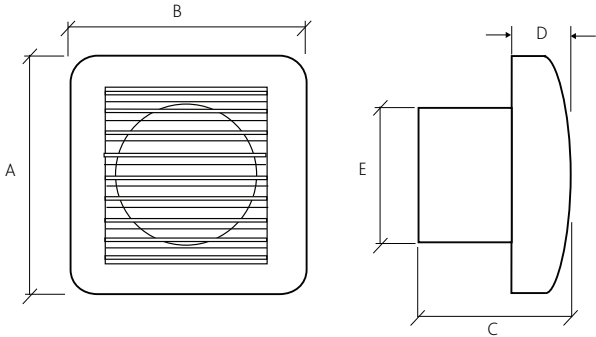

Unit	A	B	C	D	E dia.	Weight (Kg)
NA100	155	155	92	35	97	1.5
NA150	209	209	137	52	149	1.5

Wiring

NA100XPC/150XPC with integral cord

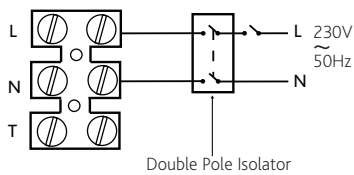

NA100XPC/150XPC

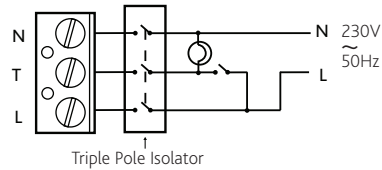

NA100XPC-12, 12V with integral cord

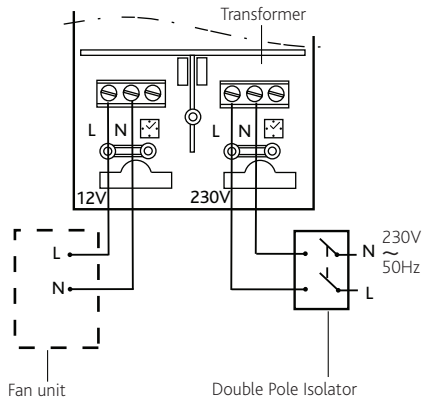

NA100XPC-12, 12V with remote switch.
(Pull-cord switch must be OFF before removing cord)

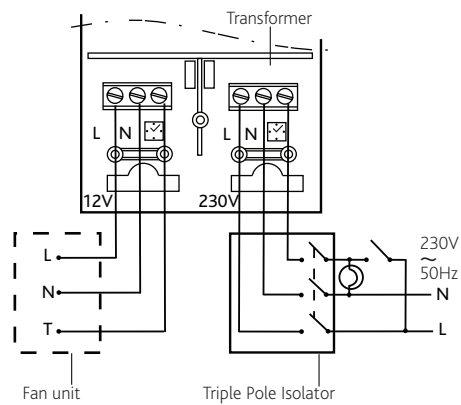

Consultants Specification

NA100 & 150 SINGLE SPEED FANS

Supplied by Nuaire Ltd the fan is to be suitable for installation either into a ceiling, wall or panel (with the appropriate accessories).

The Slimaire 100 can be window mounted and a window mounting kit is available (order code NA100-WK)

There should be a neon on the front of the fan to indicate when it is operating.

The fan casing should be made of shockproof, high quality technopolymer, contain double insulated motors of shaded poly type mounted on self lubricating, sealed ball bearings for long life, and be protected with a thermal cut-out.

The fan should be double insulated and be suitable for installation into Zones I and II.

The fan is to be CE marked and comply with current EC Low Voltage Directive EMC89/336 and with BSEN60529.

The fan should finally comply with Building Regulations requirements for installation into a utility room.

NA100X & 150X TWIN SPEED FANS

Supplied by Nuaire, this fan can either be for installation in a wall, panel, ceiling or window (with optional kit).

The fan should have three speeds, allowing a choice of one of the two lower speeds for quiet, continuous operation at installation. The user should be able to boost the fan to its maximum speed as necessary.

The fan should be made of shockproof high quality polymer and have a maintenance free, self lubricating sleeve bearing motor for long life and incorporates thermal cut-out.

The fan should be double insulated, splash proof and CE marked.

The fan should comply with Kitchen and Bathroom requirements of System 3, Part F1 of the Building Regulations. It should be capable of operation up to 9 l/sec, at 4 Pa, 2.6 watts at low speed 1, and at 12 l/sec, 14 Pa and 4.8 watts at low speed 2.

Finally the fan should comply with EN 60335-2-80, EC Low Voltage Directive LVD 2006/95/CE and EC Directive EMC2004/108 and be CE marked.

Decentralised dMEV

(whole home mechanical extract ventilation)

dMEV is a flexible solution offering three installation options; through the wall, wall/ceiling mounted with ducting to outside, as well as allowing the fan to be mounted inline and ducted to both the room and outside wall. dMEV is SAPQ listed for all three options.

A quiet, energy efficient 2 speed continuous ventilation system designed for wet room applications, the compact dMEV range of fans measure no more than a mini tablet device.



Performance

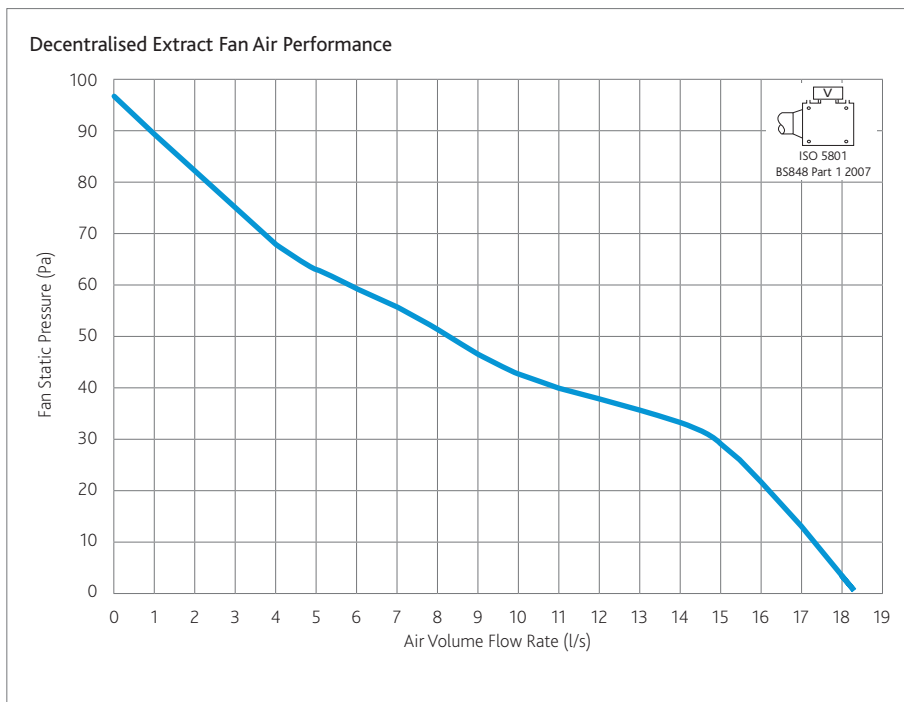

CODE DESCRIPTION

dMEV+ H



1. Decentralised Mechanical Extract Ventilation Unit
2. Decentralised Mechanical Extract Ventilation Unit with higher duty set points
3. Integral Humidistat (wall and ceiling mounted only)



Sap Appendix Q Test Results

	dMEV
Application	Specific Fan Power (W/l/s)
In-room fan - kitchen	0.20
In-room fan - other wet room	0.24
In-duct fan - kitchen	0.19
In-duct fan - other wet room	0.24
Through wall fan - kitchen	0.19
Through wall fan - other wet room	0.25

Electrical & Sound

	Extract setting (l/s)				Power consumption (Watts)				dBA @3m			
	Wet Room		Kitchen		Wet Room		Kitchen		Wet Room		Kitchen	
	Normal	Boost	Normal	Boost	Normal	Boost	Normal	Boost	Normal	Boost	Normal	Boost
dMEV	4	8	6	13	1	2.5	1.1	3	10	21	14	26
dMEV+	6	13	8	18	1.1	3	2.5	3.8	14	26	21	35
dMEVH	4	8	6	13	1	2.5	1.1	3	10	21	14	26
dMEV+H	6	13	8	18	1.1	3	2.5	3.8	14	26	21	35

General Arrangement

DIMENSIONS (MM) - FAN UNIT AND GRILLE

View of fan unit without grille

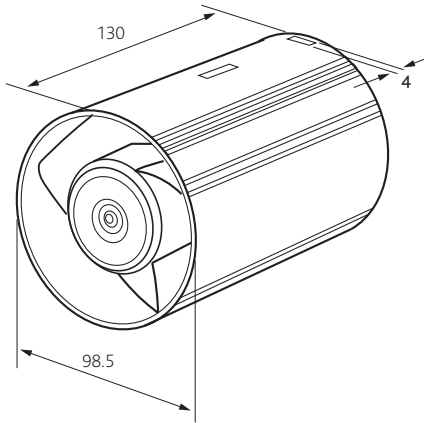

Unit weight: 0.5kg

Back view of fan unit and grille

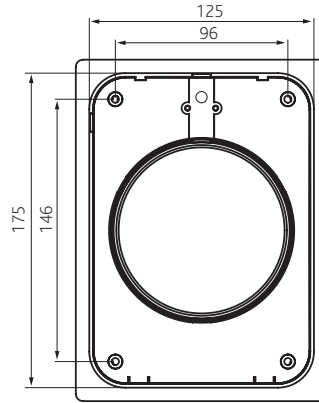

Side view of fan unit and grille

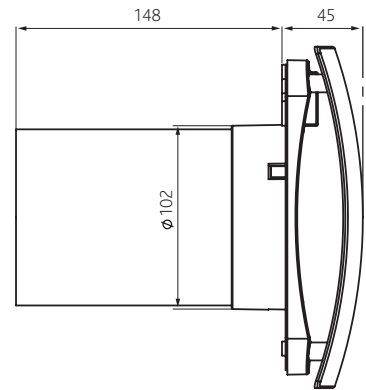

View of grille and fan unit

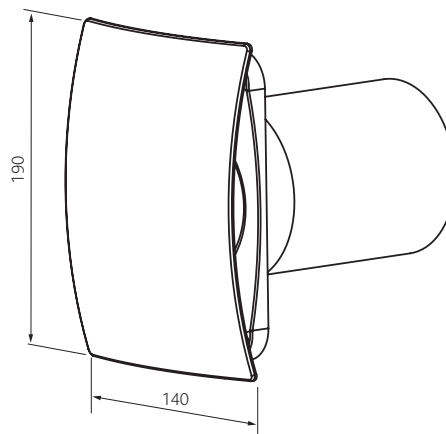

Top view of fan unit and grille

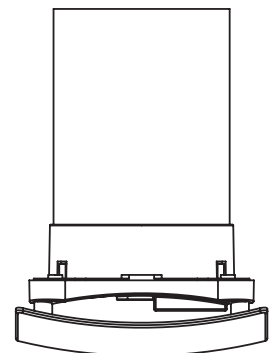

Ancillaries Available



Wall Kit

Code: (dMEV-WALLKIT)



Inline Installation Kit

Code: (dMEV-INLINE-KIT)



In-room Installation Kit

Code: (dMEV-INROOM-KIT)

Electrical Details

Voltage	230V	
Frequency	50Hz	
Operating Temperature	50°C	
Speed	Low (l/s)	Boost (l/s)
dMEV/H (Low)	4	8
dMEV/H (High)	6	13
dMEV+/H (Low)	6	13
dMEV+/H (High)	8	18

Wiring

UNIT SERVING BATHROOM OR KITCHEN (OPTIONAL BOOST)

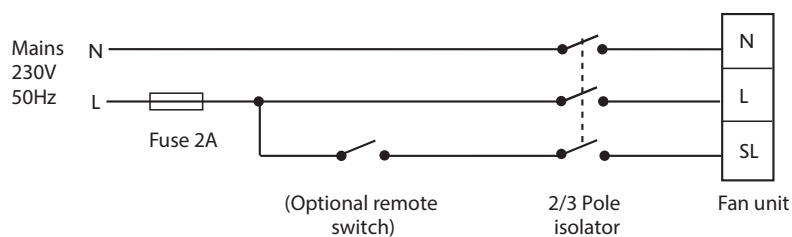

UNIT SERVING BATHROOM (VIA LIGHT SWITCH)

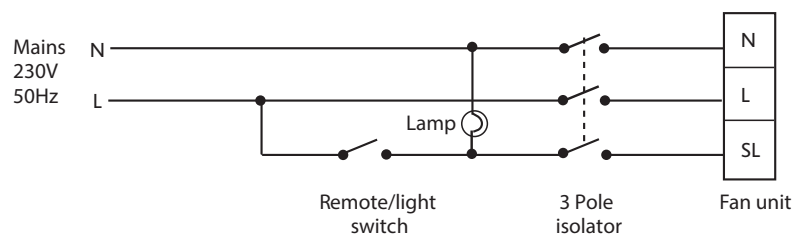

Consultants Specification

dMEV(H) / dMEV+(H) KITCHEN AND WET ROOM FAN

The unit shall be manufactured by Nuaire.

The National Calculation Method (SAP) identifier for this product is Decentralised Mechanical Ventilation Equipment (dMEV).

The unit shall be surface mountable or duct mounted using optional fixing kit. For duct mounting the fan section shall be removable and the fascia used as the inlet cowl.

The unit shall have 2 speed settings - low or high.

- The dMEV(H) unit set at low speed shall achieve 4 l/s and 8 l/s (Boost).
- The dMEV(H) unit set at high speed shall achieve 6 l/s and 13 l/s (Boost).
- The dMEV+(H) unit set at low speed shall achieve 6 l/s and 13 l/s (Boost).
- The dMEV+(H) unit set at high speed shall achieve 8 l/s and 18 l/s (Boost).

Unit noise level shall not exceed 21dBA @3m for kitchens and 14dBA for wet rooms (normal running).

The unit shall incorporate an injection moulded, 3 blade axial impeller.

The impeller shall be directly driven by a low energy, high efficiency EC motor, fitted with sealed, self-lubricating ball bearings.

IPX4 rated.

Suitable for bathroom zone 1 applications.

Motors shall have locked rotor protection to prevent overheating in the event of fan failure.

Each unit is capable of being set to comply with new edition (2010).

Part F – ventilation building regulations for (System 3) continuous mechanical extract (MEV) and new edition (2010) Part L - conservation of fuel and power.

The unit will meet the requirements of Part F for the following installations:

- Fan mounted within room with a maximum of 2.5m of rigid PVC ducting (Nuaire part number PVC1200-4WH),
2 off 90 Deg bends (Nuaire part number PVC490WH),
1 off low resistance extract grille (Nuaire part number PVC104LR).
- Fan mounted through a wall with 300mm rigid PVC ducting,
1 off low resistance extract grille. (Nuaire part number PVCWALL/6).
- Fan mounted in-duct with a maximum of 2.5m of rigid PVC ducting (Nuaire part number PVC1200-4WH),
2 off 90 Deg bends (Nuaire part number PVC490WH),
1 off low resistance extract grille (Nuaire part number PVC104LR).

Unit can comply with BRE digest 398 under continuous mechanical extract ventilation.

Meets the minimum fan power requirement of 0.5w/l/s in the 'Domestic Building Services Compliance Guide' (2010 edition).

The unit shall be designed for quietest operation to ensure occupant satisfaction.

The unit shall incorporate electrical connections to allow for the unit's "boost" airflow to be triggered by switched live.

The unit shall be supplied with a 5 year warranty. 1 Year parts and labour, additional 4 year parts.

dMEVH mounting options

Humidistat option available through wall and through ceiling mounted. Fully adjustable humidistat from 50-100RH.

Notes



NUAIRE LIMITED

Western Industrial Estate
Caerphilly
CF83 1NA

Residential product orders or enquiry:

Tel: +44 (0)29 2085 8500
Fax: +44 (0)29 2085 8555
info@nuaire.co.uk

After sales technical support:

Tel: +44(0)29 2085 8400
Fax: +44(0)29 2085 8555
info@nuaire.co.uk

www.nuaire.co.uk

 @nuaireHomes

As part of our policy of continuous product development Nuaire reserves the right to alter specifications without prior notice. Telephone calls may be recorded for quality and training purposes.