

This drawing belongs to JOPER
it is not allowed to be showed or
reproduced without its permission

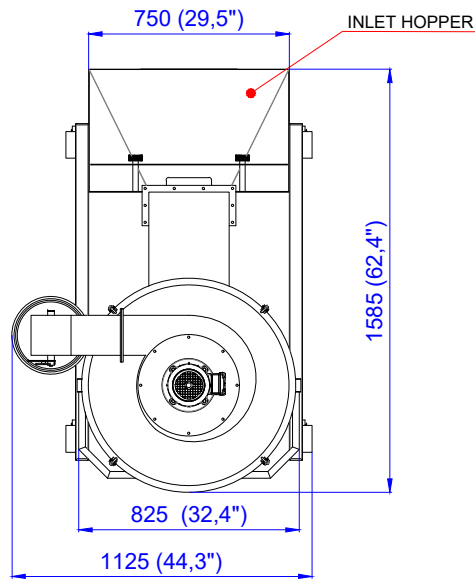
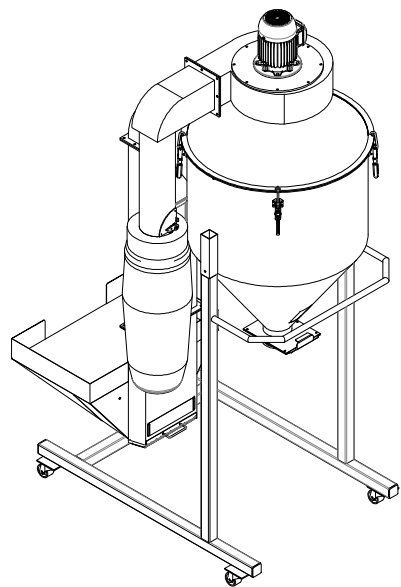
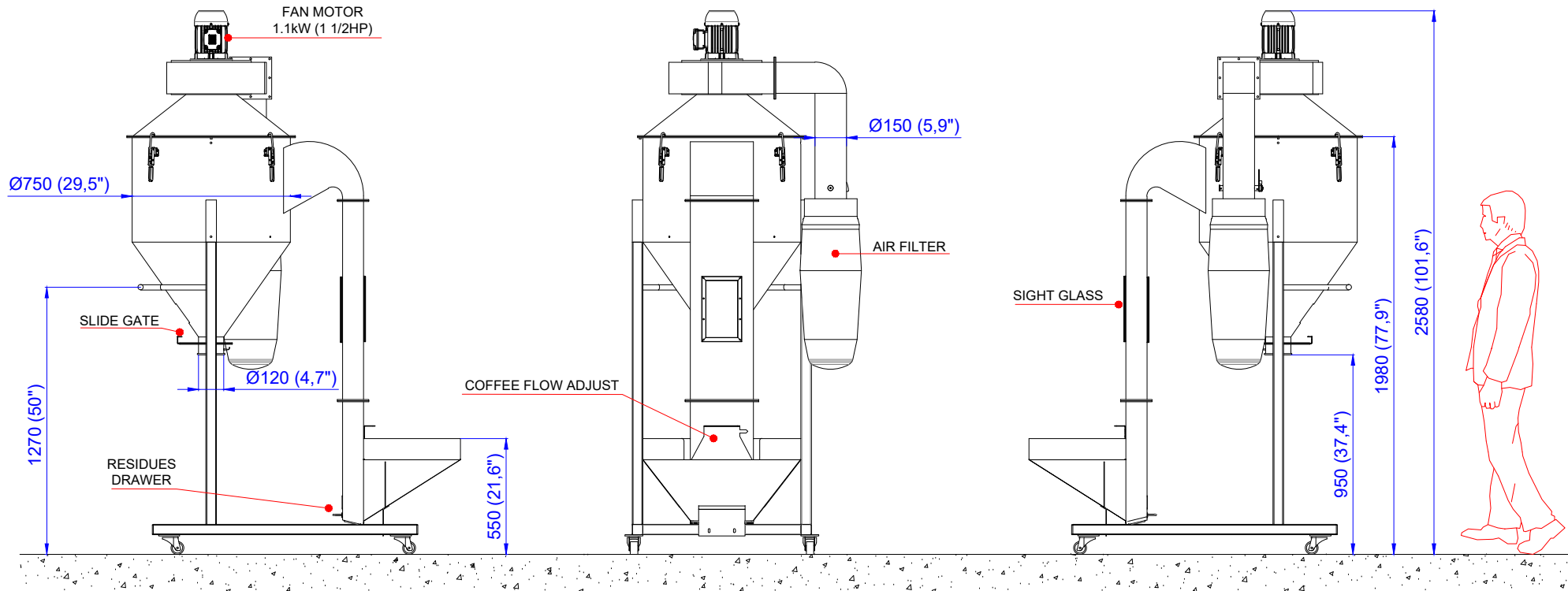

DESTONER WEIGHT : 180 KG (400 Lbs)
 SHIPPING CRATE
 > DIMENSIONS: 175x110x223 cm (68,8"x43,3"x87,7")
 > WEIGHT : 300 KG (660Lbs)

ORIGINAL

				Date	Name	Scale: 1:20
				Proj.		Designation: DESTONER DM 25-30 (GENERAL LAY-OUT)
				Des.	07.03.21 João	
				Conf.		
				Verif.		
				JOPER		Drawing: N° DM.25-30.001
				Belongs:		
Pos.	Reason	Date	Exec.	Verif.	Origin:	Sheet
REVISIONS						Subst. by: