

**PRIMO ROASTING  
RANGER-XR5  
CATALOG**



## Table of Contents

Table of Contents .....	2
1. About Primo Roasting .....	3
2. Ranger-Xr5 Key Features .....	4
3. Ranger-Xr5 Roaster Specifications .....	5
4. Ranger-Xr5 Roaster Drawings .....	6
Front View .....	7
5. Color Options .....	8
6. Pricing and Warranty .....	9
7. Safety Information .....	10
8. Things to Consider - Movement .....	11
9. Pre-Installation - Receiving/Un-crating .....	12
10. Installation - Electrical, Gas, and Ducting .....	13
11. Operating - Starting Machine/Roasting .....	14
12. Cooling and Shutoff - Cooler/Agitator .....	15
13. Maintenance and Cleaning .....	16
14. Annual Cleaning and Roasting Log .....	17
15. Cleaning Log .....	18
16. Customer Service/Parts .....	19



# ***RANGER-Xr5***

## **5.4 kg Roaster**

### **About us**

With over 28 years of expertise & experience, Primo Roasting Equipment is proud to be regarded as a manufacturing leader.

As veterans in the industry, Primo Roasting Equipment has a wealth of knowledge and expertise that's incomparable. We utilize this experience to provide both companies and individuals with quality and innovative products they can truly count on.

### **Includes**

- Two-stage digital temp controller.
- Chaff Cyclone Collector.
- Brushed Stainless Steel Faceplate.
- Infrared Burner.

In all machine sizes, Primo Roasters use specially designed paddle mechanisms to move the coffee in the drum efficiently, creating an even roast throughout the beans. Our variable rotation speed allows different batch sizes to be roasted on the same machine. Our drum, airflow, and paddles keep the beans movement consistent inside the drum. Our precise hot airflow roast the beans with as little drum contact as possible. Primo Roaster's features create a steady bean pattern and an unvarying, quality roast.

The high processing quality of the Primo Series is partly thanks to its premium design. The machines roast and cool simultaneously, with individual exhaust for cooling and roasting air. We use automated gas control with infrared ceramic burner technology for ease of use and consistent batch quality control. Our two stage temperature controller with automatic thermal control comes standard on ALL Primo Roasters.

The Ranger-Xr5 roaster can roast batch sizes up to 12 pounds (5.4kg) and has a roasting capacity of 40 pounds per hour (18.14kg per hour), this roaster is perfect for roasting, testing, and mastering specialty coffee.

## Features

- Specially designed paddles keep mixing consistent.
- Automated two-stage temperature controller.
- Variable drum speed control for different batch sizes.
- Roast and cool simultaneously with dual motors.
- Independent drum airflow motor to allow consistent roast/airflow and prevent airflow disruption from cooling.
- Independent cooling motor to allow efficient cooling without disrupting drum airflow.
- Includes independent cyclone for maximum chaff collection.
- Accessible chaff bin for ease of emptying.
- Hinged sidewalls to make cleaning as seamless and simple as possible.
- 100% of all Primo Roasters are designed and manufactured in the U.S.A.

## Care Free Roasting



Hand built coffee roasters that are simplified for all coffee roasters (beginner, intermediate, & advanced). Our Primo Roasting line produces some of, if not the most quality & phenomenally roasted beans.

## Highest Quality Materials



Here at Primo Roasting we use the highest quality American steel possible, we build reliable coffee roasters for a life long operation.

## American Craftmanship



Each machine is hand built by skilled craftsman and individually tested.

## Personal Attention



By purchasing a Primo Roaster, you are assured the best support from start to finish.



# Roaster Specifications



<b>RANGER-XR5</b>		
<b>BATCH CAPACITY</b> <b>18% WEIGHT LOSS</b>	<b>MAX GREEN</b> <b>5.44 KG / 12 LBS.</b>	<b>ROASTED</b> <b>4.5 KG / 10 LBS.</b>
<b>ROASTED CAPACITY PER HOUR.</b>		<b>18.14 KG-H / 40 LBS-H</b>
<b>GRATED SHIPPING WEIGHT.</b>		<b>700 LBS.</b>
<b>DIMENSIONS</b>	<b>74" HIGH X 38.5" DEEP X 26" WIDE</b>	
<b>ELECTRICAL</b>	<b>110 V = 14.5</b> <b>AMPS</b>	<b>220 V = 7.5</b> <b>AMPS</b>
<b>CFMS</b>	<b>ROASTING = 160</b>	<b>COOLING = 160</b>
<b>GAS SUPPLIED</b> <b>3/4" INLET</b>	<b>NATURAL</b>	<b>PROPANE</b>
<b>VENTING</b>	<b>CHAFF COOLER VENT= 6"</b>	
<b><u>STANDARD FEATURES</u></b>		
<ul style="list-style-type: none"> <li>• <b>BRUSHED STAINLESS FACE PLATE.</b></li> <li>• <b>CHAFF CYCLONE COLLECTOR.</b></li> <li>• <b>INFARED BURNERS.</b></li> <li>• <b>SPEED CONTROLLER.</b></li> <li>• <b>TWO STAGE DIGITAL TEMPERATURE CONTROLLER.</b></li> </ul>		
<b><u>UPGRADES AVAILABLE</u></b>		
<ul style="list-style-type: none"> <li>• <b>CUSTOM TRIM COLOR OPTIONS.</b></li> <li>• <b>DeSTONER WITH 250 LB. SILO.</b></li> <li>• <b>DeSTONER WITH NO SILO.</b></li> <li>• <b>GREEN COFFEE LOADER.</b></li> <li>• <b>HOPPER SCALE.</b></li> <li>• <b>INDUSTRIAL AFTERBURNER.</b></li> <li>• <b>MANUAL GAS VALVE.</b></li> <li>• <b>USB PORT FOR ROASTING PROFILE SOFTWARE.</b></li> </ul>		

## **Ranger-Xr5 Roaster Drawings**

This section contains drawing views with dimensions and component descriptions. These drawings are valuable for familiarization with the Primo Ranger-Xr5 roaster and for space and utility connection planning. There are also drawings of the Ranger-Xr5 roaster with optional loader, destoner, cyclone, and afterburner. Dimensions and some details are subject to change.

These drawings each take a full page so the remainder of this page is intentionally blank.

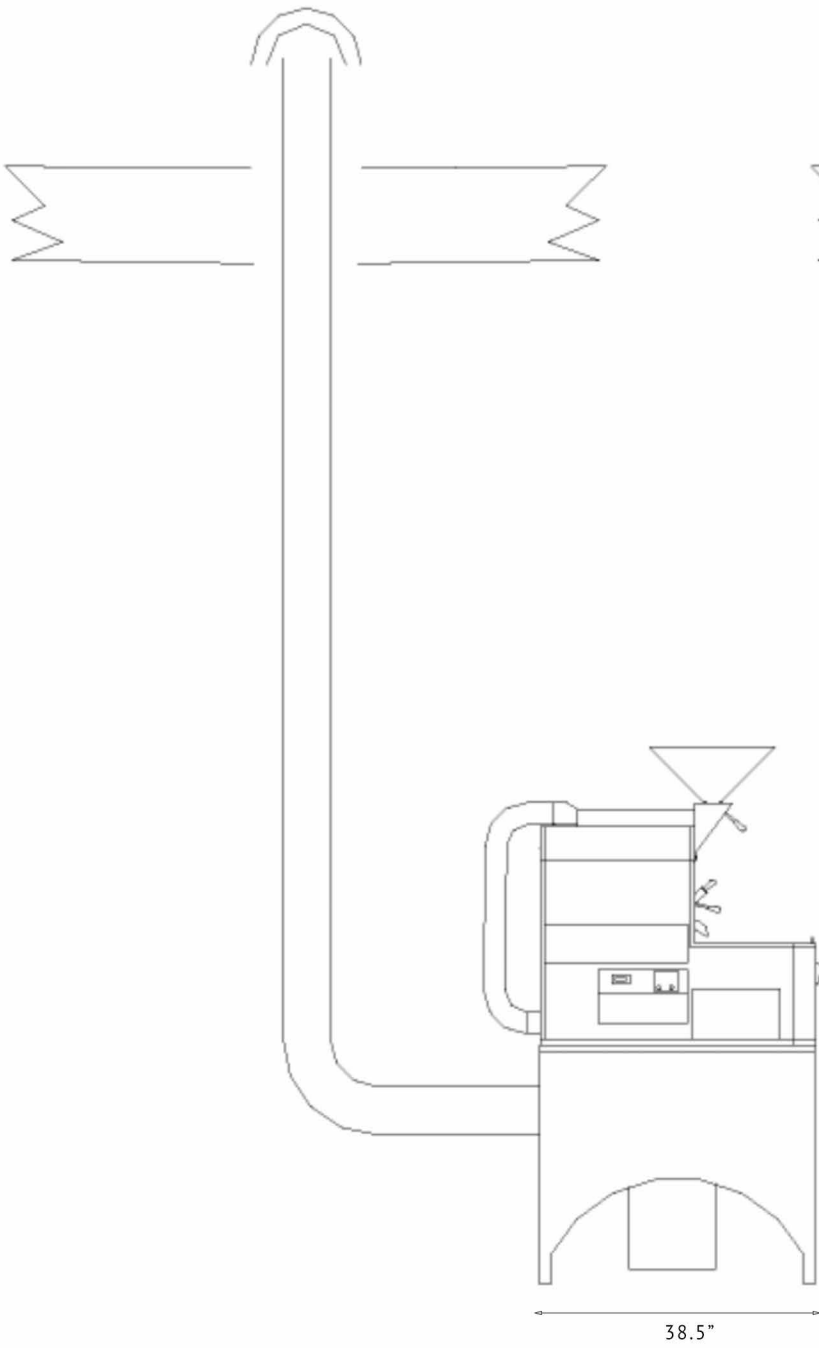

Left Side View  
Scale 1:30

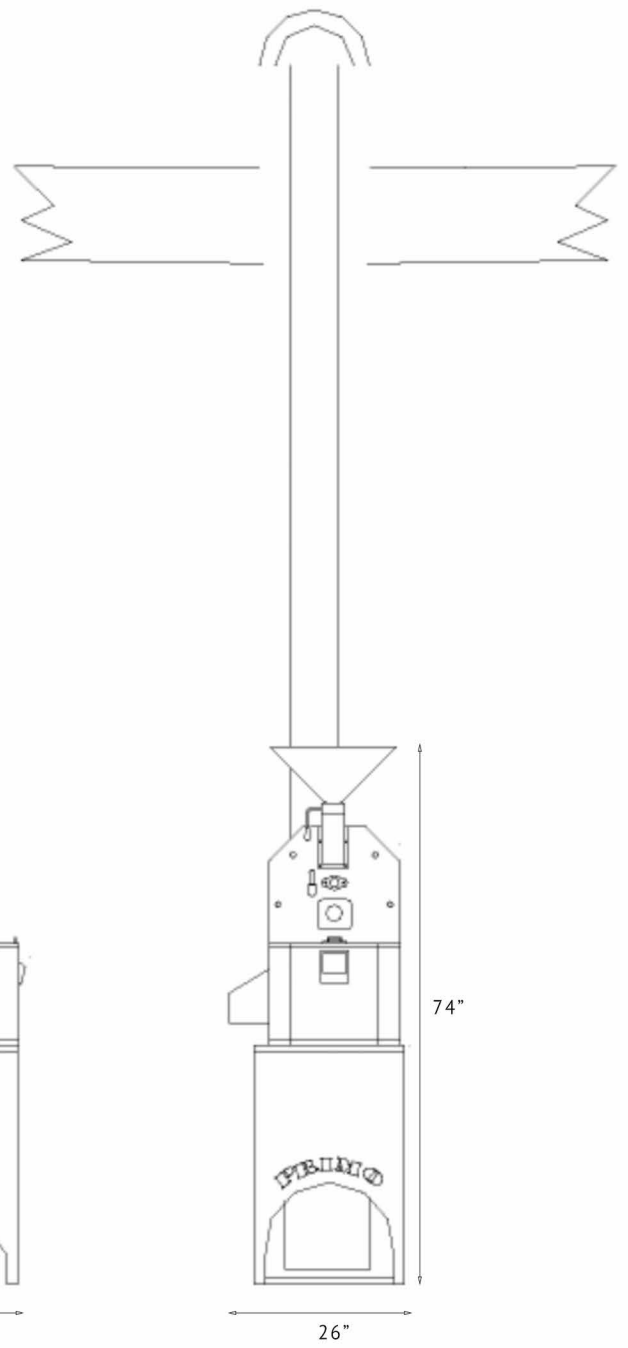

Front Side View  
Scale 1:30

# Color Options



Customization may have additional fees.

Contact us for a quote.

1000	1001	1002	1003	1004	1005	1006	1007
1011	1012	1013	1014	1015	1016	1017	1018
1019	1020	1021	1023	1024	1027	1028	1032
1033	1034	2000	2001	2002	2003	2004	2008
2009	2010	2011	2012	3000	3001	3002	3003
3004	3005	3007	3009	3011	3012	3013	3014
3015	3016	3017	3018	3020	3022	3027	3031
4001	4002	4003	4004	4005	4006	4007	4008
4009	5000	5001	5002	5003	5004	5005	5007
5008	5009	5010	5011	5012	5013	5014	5015
5017	5018	5019	5020	5021	5022	5023	5024
6000	6001	6002	6003	6004	6005	6006	6007
6008	6009	6010	6011	6012	6013	6014	6015
6016	6017	6018	6019	6020	6021	6022	6024
6025	6026	6027	6028	6029	6032	6033	6034
7000	7001	7001	7002	7003	7004	7005	7006
7008	7009	7010	7011	7012	7013	7015	7016
7021	7022	7023	7024	7026	7030	7031	7032
7033	7034	7035	7036	7037	7038	7039	7040
7042	7043	7044	8000	8001	8002	8003	8004
8007	8008	8011	8012	8014	8015	8016	8017
8019	8022	8023	8024	8025	8028	9001	9002
9003	9004	9005	9010	9011	9016	9017	9018



# Pricing

Starting Price - \$21,495.00 USD

MOST COST EFFICIENT IN THE INDUSTRY.

Additional Add-ons Available

De-Stoner - Contact Us

Storage Silo - Contact Us

Vacuum Green Coffee Loader - Contact Us

Additional Equipment Available Upon Request.

# Warranty

The Best Equipment Warranty in the industry.

Primo Roasting Equipment warranties roasting equipment to the original user, against defects in workmanship or material. This Warranty covers all parts, components, and machinery for two (2) years.

Warranty takes effect on the date of your ownership and shipment by Primo Roasting Equipment or Primo's representatives. This Warranty does not apply where damage is caused by shipping or handling, if the roaster has been abused, misused or improperly maintained in a manner not consistent with the servicing or maintenance guidelines set fourth by Primo instructions or equipment has been altered in any way.

# 1. Safety Information

Prior to installing & operating your roaster please read the entire manual. If you see this symbol in the manual, make sure to read what follows because it is a caution for actions that can cause harm or damage to your machine and/or the operator.

Death, injury, or property damage can be caused because of improper installation, adjustment, alteration, service, or maintenance. The entire installation guide must be read prior to installing, cleaning, operating, or servicing this roaster.



It is the owner's responsibility to ensure the installation, cleaning, and operation of the roaster are done safely/properly. Only a qualified professional should operate this roaster.

Keep any flammable items including but not limited to, gases, vapors, liquids, & solids, far away from the roaster at all times. The roaster needs to have a fire extinguisher nearby easily accessible incase of fire. Your local fire department will have information on which fire extinguishers should be used. Fires may be caused from not cleaning the roaster or exhaust system correctly and/or often enough.

The roaster needs 18 inches of space around it at all times. Do not touch hot surfaces.

Once the installation of the roaster is completed, you will need to have it inspected to ensure it is compliant to local building codes. A local fire inspector must also inspect the machine. These things must be done prior to operating. The Primo Roasting Equipment warranty may be null/void if the inspections are not done. This would relieve Primo Roasting Equipment from any liability that has to do with the use of the machine & how the installation was done.

Instructions for what to do when the roaster operator finds a gas leak and/or smells gas need to be posted in a location easily accessible/readable. Your local gas company or company that supplies gas will have the instructions for you to get from them.

## 2. Things to Consider

### i. Ease of Movement

**ATTENTION: Prior to moving machine and/or cyclone make sure the roaster is turned off, unplugged, and the gas is disconnected/off.**

To move the roaster and/or cyclone the machine must be taken apart.

1. Remove exhaust arm by pulling it off via compression fittings and set aside.
2. Unbolt cyclone from ground if applicable
  - (1) Use forklift to pickup machine from the back \*make sure to tilt forklift back once the roaster is lifted up to avoid it sliding off or tipping the forklift\*
3. Place roaster in desired location using the installation guide/spacing requirements,

Make sure to leave ample room behind the machine in order to let forklift have access for movement purposes.

\*Every time the machine is moved, disassembled, & put back together the operator must inspect machine prior to resuming operations\*

### **3. Pre-Installation**

#### **i. Receiving/Un-Crating**

##### **Roaster:**

The roaster comes in a crate (pallet with wooden walls & top) with a plastic cord strapping it down to the pallet base.

Pry off crate walls to expose roaster.

\*Be careful not to drop/slide the tool you are using to pry into the crate, on the roaster\*

Once all walls are taken off, cut plastic cord strapped over the cooler to the pallet

Once the roaster is free standing on the pallet use forklift to move off of the pallet

Pick up roaster from the back of the machine to get off of the pallet

\*Make sure to tilt the forklift arms up once roaster is in the air\*

\*We recommend keeping the roaster as close to the ground as possible when moving\*

Set roaster in desired area

\*Spacing requirements further down\*

##### **Cyclone:**

The cyclone comes bolted down on a pallet, wrapped in plastic.

Remove plastic wrap from cyclone & pallet

Move pallet as close to desired position for the cyclone to make moving it easier.

\*Use spacing requirements further down\*

Remove bolts from cyclone legs

\*Use BLANK size BLANK\*

Pick up cyclone using forklift in between the cyclone arms

\*Wrap and protect the forklift arms/cyclone arms to prevent abrasion on the cyclone when moving\*

Place cyclone on correct side of roaster using spacing requirements below

#### **ii. Spacing Requirements**

Access to drop chutes, panel, chaff bin, loading hopper, etc.

The switches and buttons are located on the left side of the machine, so keep that in mind when placing roaster in the position for operation.

Space to get to back of roaster & for venting

The footprint of the roaster and cyclone attached is BLANK by BLANK feet.

The cyclone needs to be placed BLANK feet to the right of the roaster. The cyclone vent should be flush with the roaster vent to make adding the exhaust arm simple & easy.

There must be easy access to the follow areas: cyclone chaff bin, left and right side cooler doors, control panel, hopper, gas line on back of roaster.

Having easy access to these places will make cleaning and maintenance much easier.

## 4. Installation

**ATTENTION: Hire a professional to install your roaster. We have made it as simple as possible to install your Primo Equipment Roaster. This manual must be read completely through prior to any installation. Check with local building authorities for their local codes & installation requirements prior to installation.**

### i. Electrical

**ATTENTION: When installing the electrical on/to your roaster use an electrical company that is licensed.**

Consult your licensed electrician to ensure proper installation of either the 110 V or 220 V, based off requested voltage.

If using 220v a 3 prong 220v will not be included and must be wired to the 3 wires from the machine.

### ii. Gas

**ATTENTION: When installing the gas line to your roaster use a gas company that is licensed.**

Local codes, regulations, and/or laws must be followed when doing the gas installation for the machine.

\*If roaster was made for propane only use propane and use a regulator.

\*Have a certified gas worker inspect and double check any gas connection work you do.\*

### iii. Roaster Funnel/Exhaust

1. Remove 4 nut caps (7/16) from hopper.
2. Place funnel slide on.
3. Place funnel on top of slide.
4. Place 4 nut caps (7/16) over bolts after funnel slide and funnel is placed on top.
5. Tighten 4 nut caps with 7/16 wrench.
6. Slide exhaust on via compression fit

### iv. Cyclone

**ATTENTION: When installing the cyclone to your roaster use a licensed contractor.**

Use 6" ducting from cyclone too vent.

Consult your licensed contractor to ensure proper installation of duct work.

To attach the exhaust arm from the roaster to cyclone you must line up the machines according to the spacing requirements. Once lined up simply put the exhaust arm in position like photo and slide onto each vent until fully on.

## 5. Operating Machine

Primo Roasters have 4 switches and 6 buttons. The switches in order from left to right: ignition (IGN), drum (DRUM), cooler (CLR), & agitator (AGT). The 6 buttons on the temperature controller are in rows of 3.

### i. Starting Roaster

1. Make sure roaster is properly connected to correct gas source.
2. Make sure roaster is properly plugged in to correct outlet.
3. Make sure the chaff bin is empty and that the under cooler & side panels are clean of debris.

How to turn roaster on:

### ii. Roasting

1. Preheat roaster before first roast for 15-20 minutes or at 400 F.
2. Turn Drum on by pushing in the drum switch on the left facing side of the roaster.
3. Next push in the ignition switch next to the drum switch to start the temperature controller.
4. Hold start on the temperature controller (middle button, lower row) until the ignitor starts. (the two red lights will turn on below the temperature display screen once burners are on. You can also look into the burner view window in order to check.)
5. Push temperature button and temp 1 will come up on the temp module, use up and down arrows to set desired temperature.
6. Push temperature button once more and temp 2 will come up on the temp module, use up and down arrows set temp 2 to desired temperature.
7. Let roaster preheat to desired temperature and stay constant for 3 minutes.
8. Fill hopper with raw material.
9. Once filling stops pull hopper door open to allow material to fall into the drum.
10. Close hopper door.
11. Once the material reaches desired temperature turn on the agitator switch and the cooler switch.
12. When material is finished open drum door to allow all material to fall into the cooling tray.
13. Allow machine to reheat prior to next material.
14. Open cooling tray door to allow first roast to be transported before the new roast reaches desired degrees.
15. Close cooling tray door when all roasted material is out of cooling tray to prepare it for the batch currently roasting.
16. Repeat steps for multiple batches.

How to turn burners on:

How to set temperatures 1 and 2:

How to use timer:

### **iii. Cooling**

#### **Cooler/Agitator**

Primo Roasters are equipped with an agitator/cooler to cool down the roasted material.

Before dropping roasted material into the cooler tray turn on the agitator and cooler switches (the right two switches).

Once your material has cooled to the desired temp you can open the cooler side door to drop material into storage bin. Be sure to close cooler door latch correctly before dropping the next batch of material into the cooler tray.

### **iv. Misc.**

#### **Shut-off**

1. Open hopper slide and the drum door when cooling to speed up cooling process.
2. Push start/stop button on temperature controller until the burners turn off.
3. Leave drum on until temp drops to 200 degrees F.
4. Turn all switches to the off position once the roaster has cooled down.
5. Close hopper slide/drum door.
6. Turn gas valves off and unplug the roaster.

## **6. Maintenance/Cleaning**

### **i. Maintenance Schedule**

#### **Changing Drum Depth:**

1. Make sure machine is turned off
  2. Loosen the two bolts on the front bearing with a BLANK size BLANK
  3. Use a rubber mallet to push the drum axle back to desired distance
- \*Use rubber mallet as to not damage the machine. Do NOT hit any other part than the front flat section of the drum axle\*

TO BRING DRUM FORWARD...

Re-tighten the two bolts

\*If not tightened properly drum will move during your next roast and may damage the roaster itself\*

#### **Grease Bearings:**

1. Add grease to front and rear bearing every 500 pounds of coffee.
2. Use greasing tool to add teflon grease to the pin on the side of the front bearing.
3. Wipe excess grease off with a rag.

### **ii. Cleaning Schedule**

**ATTENTION: Unplug machine prior to cleaning. Turn gas valve off prior to cleaning machine. Let machine cool down if hot prior to cleaning to avoid injury.**

#### **Daily Cleaning**

1. Empty chaff bin beneath cyclone by removing the chaff bin and vacuuming the chaff out. Remove the bin by sliding it away from the front of the cyclone. \*Be sure the chaff bin is below cyclone prior to operating machine.\*
2. Open side cooler doors to vacuum out chaff that has fallen below the cooling tray. \*Be sure to close both doors and lock latches before operating machine.\*
3. If the cooling tray screen has any blockages in it be sure to clean them out via a brush or tool to ensure maximum cooling is taking place.
4. Open side panels on roaster by turning each of the 3 knobs and lowering the panel. Remove the heat shield. Vacuum out the burner area to clear all chaff. \*Be sure side panels are closed properly before your next roast.\*

#### **Every 10th Day Cleaning**

1. Clean exterior of machine/cyclone using either compressed air or microfiber cloth.
2. Inspect front/rear drum bearings and lubricate as necessary.
3. Inspect venting system from roaster to cyclone, cyclone to vent, and roaster to vent for blockage. Clean as necessary.
4. Inspect all ducting on roaster/cyclone for accumulation. If necessary clean and remove the accumulation prior to cleaning.
5. Check blower motor fan and if necessary, clean.



## Annual Cleaning

1. Check all visible bolts/screws and tighten/replace if necessary.
2. Have a professional chimney cleaner sweep clean the exhaust ducting.

## Coffee Roasting Log (      )

Date: \_\_\_\_\_

Green Coffee				Batch Size: _____			
Steps	RPM: _____	B. Temp.	Time	Vent.	Gas	E. Temp	M.E.T.
	1		°F 00:00			°F	°F
	2		°F :			°F	°F
	3		°F :			°F	°F
	4		°F :			°F	°F
	5		°F :			°F	°F
	6		°F :			°F	°F
	7		°F :			°F	°F
	8		°F :			°F	°F
	9	Finish	°F :		:	R.D.T.	°F

Date: \_\_\_\_\_

Green Coffee				Batch Size: _____			
Steps	RPM: _____	B. Temp.	Time	Vent.	Gas	E. Temp	M.E.T.
	1		°F 00:00			°F	°F
	2		°F :			°F	°F
	3		°F :			°F	°F
	4		°F :			°F	°F
	5		°F :			°F	°F
	6		°F :			°F	°F
	7		°F :			°F	°F
	8		°F :			°F	°F
	9	Finish	°F :		:	R.D.T.	°F

Date: \_\_\_\_\_

Green Coffee				Batch Size: _____			
Steps	RPM: _____	B. Temp.	Time	Vent.	Gas	E. Temp	M.E.T.
	1		°F 00:00			°F	°F
	2		°F :			°F	°F
	3		°F :			°F	°F
	4		°F :			°F	°F
	5		°F :			°F	°F
	6		°F :			°F	°F
	7		°F :			°F	°F
	8		°F :			°F	°F
	9	Finish	°F :		:	R.D.T.	°F

**iii. Roasting Log**

**iv. Cleaning Log**

<b><u>EVERY DAY</u></b>	DATE/TIME COMPLETED	INITIALS
Clean chaff from under cooler tray.		
Empty chaff bin from under cyclone.		
Make sure cooler screen tray is clear of any blockage and clean if necessary.		
Clean chaff from inside burner panels on each side.		
<b><u>EVERY 50 HOURS OF ROASTING OR 10 DAYS</u></b>		
Clean entire exterior of machine.		
Inspect front/rear drum bearings and lubricate as necessary.		
Inspect venting system from roaster to cyclone, cyclone to vent, and roaster to vent for blockage. Clean as necessary.		
Inspect all ducting on roaster/cyclone for accumulation. If necessary clean and remove the accumulation prior to cleaning.		
Check blower motor fan and if necessary, clean.		
<b><u>ONCE A YEAR</u></b>		
Check all visible bolts/screws and tighten/replace if necessary.		
Have a professional chimney cleaner sweep clean the exhaust ducting.		

## **7. Customer Service/Parts**

Primo Roasting Equipment does NOT stop helping you once your machine is shipped out. Our machines come with a 2 year full warranty on parts and after those 2 years are up we have dependable customer service and parts team ready to help with any issue. Primo Roasting Equipment machines are still running from 10-15 years ago smoothly after continuous production. All parts are stocked and ready to ship when you need them.

If you ever have any questions/issues do not hesitate to contact us at (714)-556-5259 or email us at [primoroastingequipment@gmail.com](mailto:primoroastingequipment@gmail.com) and we will find a solution as soon as possible!

**Contact us**  
PRIMO ROASTING  
EQUIPMENT



**(1)-800-675-0160**

Available from Monday 12:00AM to Sunday 11:59PM (PT)

**Address:** 1309 South Lyon St. Santa Ana CA 92705

**Phone:** 714-556-5259

**Email:** Sales@PrimoRoasting.com