

Product Range

Solar Collector:

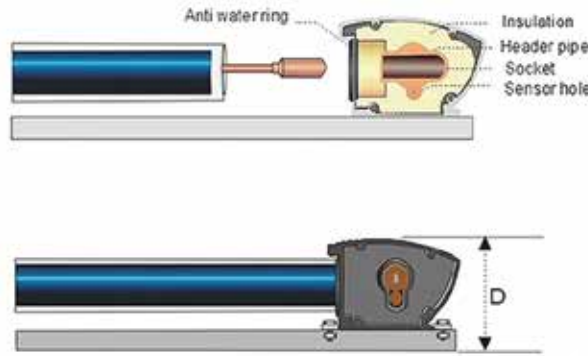
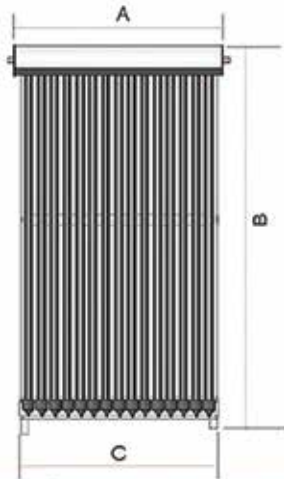

Model:		CE-ST15COL	CE-ST30COL
Condenser	mm	24	24
Capacity	L/Day - 60C	140-150	250-300
Effective collector area	m ²	1.95	3.91
Size A	mm	1295	2420
Size B	mm	2020	2020
Size C	mm	1230	2355
Size D	mm	123	123

- High efficiency vacuum tube collectors
- Works down to -30c & in cloudy conditions
- 22mm Inlet / Outlet
- Each tube works independantly
- Daily efficiency >55% Summer / >42%Winter
- 12 Bar max pressure
- ALN/AIN-SS/CU Vacuum Tube Coating

Controller

Model: CE-STCON

Our digital solar thermal controller compares the temperature in the storage tank (or buffer) against the temperature on the solar collector. It then switches the pump on automatically if there is a demand for heat and a higher temperature at the collector.

- The controller kit includes:
- Digital Controller Interface
 - Wiring Centre & Temperature Probes.

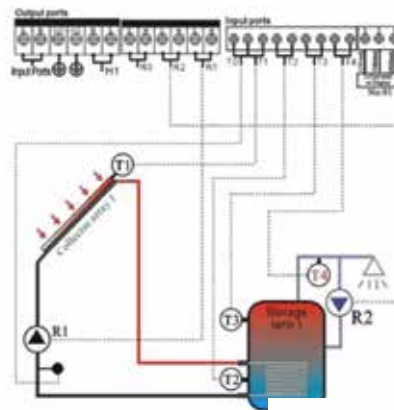

Pump Station

Model: CE-STPUMP

Our solar pump station is used to pump the heat transfer medim around the system.

The pump station kit includes: temperature / pressure gauge, flow meter with balacing / filling valve, safety valve & pump.



Specifications subject to change without warning.



Product Range

Solar Kits:



Model: CE-STKIT1 / CE-STKIT2

Includes:
 Solar Vacuum Tube Collector, 1 x Solar Controller, 1 x Solar Pump Station, 1 x 15m Roll DN16 Twin Insulated Pipe, 1 x 10L Solaris DTX Glycol, 1 x Discharge Container, 1 x 8L Expansion Vessel, 1 x Vessel Bracket & 6 x Brass Solar Fittings



Accessories

Solar Cylinders:



All In One EcoStore Heat Pump Cylinders

CE-ES200
CE-ES300



Dual Coil Invented Cylinders

CE-INOX200DC
CE-INOX250DC
CE-INOX300DC

Pipework / Fittings / Other:



22mm Comp, x DN16 Comp, CE-5051



22mm Spigot x DN16 Comp, CE-5061



3/4" Male x DN16 Comp CE-5081



Solar Expansion Vessels

CE-STEX8L
CE-STEX19L
CE-EXBRKT - Bracket



Solar Discharge Container

CE-STEVPG550001



CE-ST10MTWPIPE
CE-ST15MTWPIPE
CE-ST25MTWPIPE



Solaris DTX Solar Heat Transfer Glycol

CE-SOLDTX10
CE-SOLDTX25

Other sizes available on request

Specifications subject to change without warning.

