

---

# Domestic Hot Water Heat Pump

- Installation and Service Manual -



Model: CE-H5 CE-H7

## TABLE OF CONTENT

<b>INTRODUCTION</b> .....	2
General information .....	2
Items inside product box .....	2
<b>SAFETY PRECAUTIONS</b> .....	3
<b>WARNING</b> .....	3
<b>CAUTION</b> .....	5
<b>OVERVIEW OF THE UNIT</b> .....	6
<b>EXPLODED VIEW</b> .....	7
<b>OPERATING THE UNIT</b> .....	8
Features and functions .....	8
User interface .....	9
Buttons .....	10
LCD operation .....	10
<b>PARAMETER CHECKING AND ADJUSTMENT</b> .....	13
Unit running status query table .....	13
Parameter settings .....	14
<b>SYSTEM PROTECTIONS/ ERROR CODES</b> .....	15
<b>WIRING DIAGRAM</b> .....	17
<b>INSTALLATION OF THE UNIT</b> .....	18
Installation guidelines .....	18
Precautions for selecting the location .....	18
Selecting a location in cold climates .....	18
Installation space .....	19
Mounting the unit .....	19
Water pipe work .....	19
Checking the water circuit .....	19
Connecting the water circuit .....	20
Charging water .....	21
Piping insulation .....	21
Field wiring .....	21
Pre-operation checks .....	22
Checks before initial start-up .....	22
Setting the pump speed .....	23
<b>MAINTENANCE</b> .....	24
<b>TROUBLESHOOTING</b> .....	25
General guidelines .....	25
<b>TEMPERATURE SENSOR R-T CONVERSION TABLE</b> .....	26
<b>WIFI APPLICATION</b> .....	28

## INTRODUCTION

This manual includes the necessary information about the unit. Please read this manual carefully before you install, operate and maintain the unit.

### General information



The heat pump water heater is one of the most economical systems to heat the water for family domestic use. Using free renewable energy form the air, the unit is highly efficient with low running costs. Its efficiency can be up to 3-4 times more than conventional gas boiler or electrical heater.

It can offer hot water all year around. Also it can be compatible with the existing geyser in household.

### Items inside product box

Thank you for choosing the heat pump water heater.

Before starting installation, please make sure that all parts are found inside the product box.

The Unit Box		
Item	Image	Quantity
LCHWC-70R		1
Installation and Service Manual		1
Control Pad		1

## SAFETY PRECAUTIONS

To prevent injury to the user, other people, or property damage, the following instructions must be followed. Incorrect operation due to ignoring of instructions may cause harm or damage.

Install the unit only when it complies with local regulations, by-laws and standards. Check the main voltage and frequency. This unit is only suitable for earthed sockets.

The following safety precautions should always be taken into account:

- Be sure to read the following WARNING before installing the unit.
- Be sure to observe the cautions specified here as they include important items related to safety.
- After reading these instructions, be sure to keep it together with the manual in a handy place for future reference.

### WARNING

#### **Do not install the unit yourself.**

Incorrect installation could cause injury due to fire, electric shock, the unit falling or leakage of water. Consult the dealer from whom you purchased the unit or a specialized installer.

#### **Install the unit securely in a place.**

When insufficiently installed, the unit could fall causing injury. When installing the unit in a small room, please take measures (like sufficient ventilation) to prevent the asphyxia caused by the leakage of refrigerant.

#### **Use the specified electrical wires and attach the wires firmly to the terminal board (connection in such a way that the stress of the wires is not applied to the sections).**

Incorrect connection and fixing could cause a fire.

#### **Be sure to use the provided or specified parts for the installation work.**

The use of defective parts could cause an injury due to possible fire, electric shocks, the unit falling etc.

#### **Perform the installation securely and please refer to the installation instructions.**

Incorrect installation could cause an injury due to possible fire, electric shocks, the unit falling, leakage of water etc.

#### **Perform electrical work according to the installation manual and be sure to use a dedicated section.**

If the capacity of the power circuit is insufficient or there is an incomplete electrical circuit, it could result in a fire or an electric shock.

#### **The unit must always have an earthed connection.**

If the power supply is not earthed, you may not connect the unit.

**Never use an extension cable to connect the unit to the electric power supply.**

If there is no suitable, earthed wall socket available, have one installed by a recognized electrician.

**Do not move/repair the unit yourself.**

Improper movement or repair on the unit could lead to water leakage, electrical shock, injury or fire.  
Have any repairs and/or maintenance only carried out by a recognized service engineer.

**Do not plug or unplug the power supply during operation**

There is a risk of fire or an electric shock

**Do not touch/operate the unit with wet hands**

There is a risk of fire or an electric shock

**Do not place a heater or other appliances near the power cable**

There is a risk of fire or an electric shock

**Be cautious that water could not be poured to the product directly, do not allow water to run into electric parts**

There is a risk of fire or an electric shock

**Working ambient temperature: -10°C to 43°C, working pressure: 0.6MPa to 4.5MPa.**

**An all-pole disconnection device which has at least 3mm clearances in all poles, and have a leakage current that may exceed 10mA, the residual current device (RCD) having a rated residual operating current not exceeding 30mA, and disconnection must be incorporated in the fixed wiring in accordance with the wiring rules.**

**If the supply cord is damaged, it must be replaced by the manufacturer or its service agent or a similarly qualified person in order to avoid a hazard.**

**This appliance has not been designed for use by persons (including children) with reduced physical, sensorial or mental faculties or by persons without any experience or knowledge of heating systems, unless they act under the safety and supervision of a responsible person or have received prior training concerning the use of the appliance.**

**Children should be supervised to ensure that they do not play with the appliance**



**IF THE PRODUCT IS NOT USED FOR A LONG TIME, WE STRONGLY RECOMMEND NOT TO SWITCH 'OFF' THE POWER SUPPLY OF THE UNIT.**



**IF THE POWER IS NOT SUPPLIED, SOME SPECIAL PRODUCT-PROTECTING ACTIONS (SUCH AS ANTI-FREEZE) WILL NOT BE PERFORMED.**

 **CAUTION**

**Do not install the unit in a place where there is a chance of flammable gas leaks.**

If there is a gas leak and gas accumulates in the area surrounding the unit, it could cause an explosion.

**Perform the drainage/piping work according to the installation instruction.**

If there is a defect in the drainage/piping work, water could leak from the unit and household goods could get wet and be damaged.

**Do not clean the unit when the power is 'on'.**

Always shut 'off' the power when cleaning or servicing the unit. If not, it could cause an injury due to the high speed running fan or an electrical shock.

**Do not continue to run the unit when there is something wrong or there is a strange smell.**

The power supply needs to be shut 'off' to stop the unit; otherwise this may cause an electrical shock or fire.

**Be cautious when unpacking and installing the product.**

Sharp edges could cause injury. Especially watch the edges and the fins on the heat exchanger of the product.

**Always check for gas (refrigerant) leakage after installation or repair of product.**

Low refrigerant levels may cause failure of the product.

**Keep level even when installing the product.**

This is to avoid vibration or water leakage.

**Do not put your fingers or others into the fan, or evaporator.**

The ventilator runs at high speed, this could cause serious injury.

## OVERVIEW OF THE UNIT

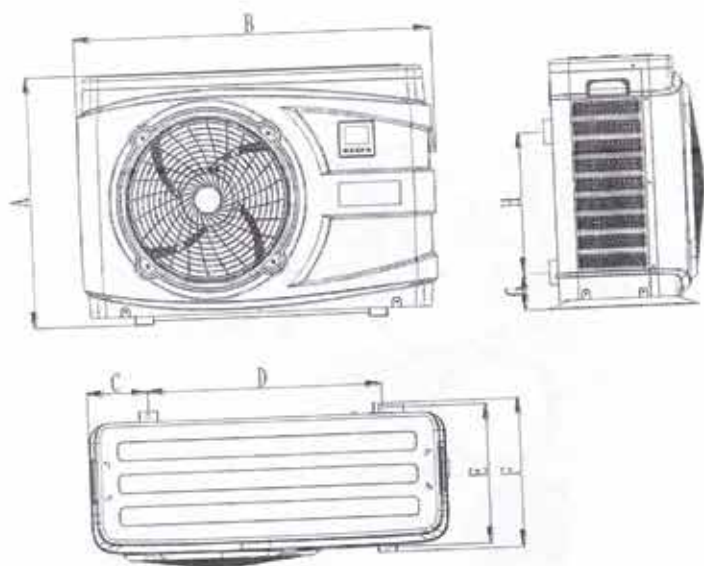

No.	CE-H5 CE-H7
A	657
B	945
C	159
D	620
E	366
F	390
G	96
H	370

## EXPLODED VIEW

MODEL: CE-H5 CE-H7

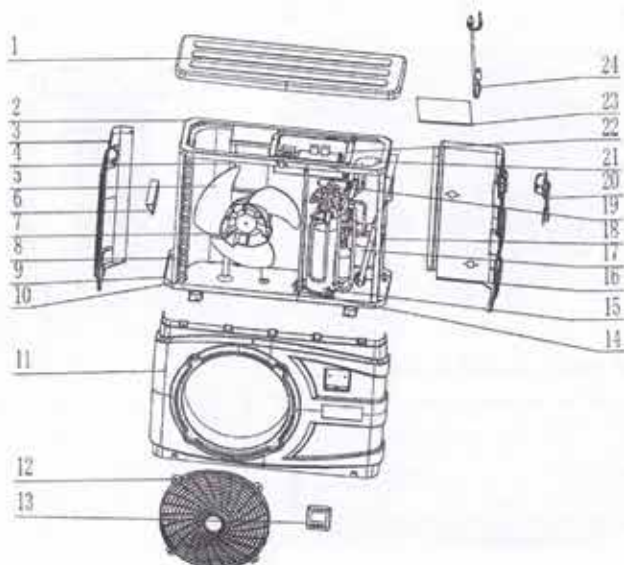



1	Top cover	13	Wired controller
2	Top metallic frame	14	Partition plate
3	Left panel	15	Compressor
4	Fan bracket	16	Right panel
5	Fan blade	17	Water pump
6	Left handle	18	Pillar 1
7	Fan motor	19	4-way valve assembly
8	Evaporator	20	Terminals cover
9	Chassis	21	Condenser
10	Pillar 2	22	Electrical box assembly
11	Front panel	23	Electrical box cover
12	Grill	24	Capillary assembly



## OPERATING THE UNIT

*Operating the unit comes down to operating the digital controller.*

-  NEVER LET THE DIGITAL CONTROLLER GET WET. THIS MAY CAUSE AN ELECTRIC SHOCK OR FIRE.
-  NEVER PRESS THE BUTTONS OF THE DIGITAL CONTROLLER WITH A HARD, POINTED OBJECT. THIS MAY DAMAGE THE DIGITAL CONTROLLER.
-  NEVER INSPECT OR SERVICE THE DIGITAL CONTROLLER YOURSELF, ASK A QUALIFIED SERVICE PERSON TO DO THIS.

## Features and functions



### Basic controller functions

The basic controller functions are:



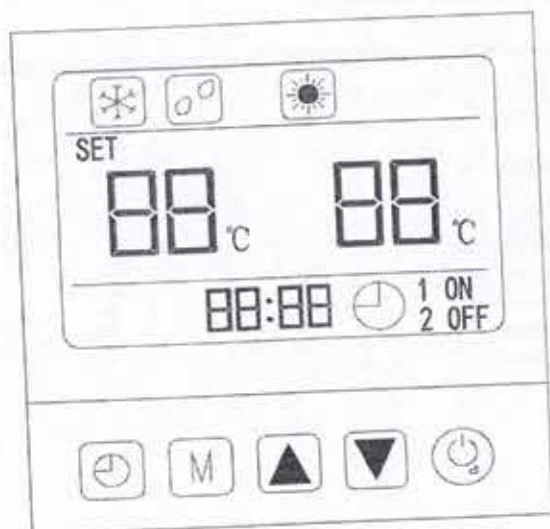







- Turning the heat pump 'ON'/'OFF'.
- 24 hours real time clock.
- Timer 'ON' and timer 'OFF'.
- Parameter adjustment

## User interface











-  NEVER LET THE DIGITAL CONTROLLER GET WET. THIS MAY CAUSE AN ELECTRIC SHOCK OR FIRE.
-  NEVER PRESS THE BUTTONS OF THE DIGITAL CONTROLLER WITH A HARD, POINTED OBJECT. THIS MAY DAMAGE THE DIGITAL CONTROLLER.
-  NEVER INSPECT OR SERVICE THE DIGITAL CONTROLLER YOURSELF. PLEASE REFER TO A QUALIFIED SERVICE ENGINEER.

## Buttons













-  Unit ON/OFF button
  - ◇ Under unit unlock status, press this button for 1 second to switch unit ON/OFF.
  - ◇ Under other setting status, press this button to return back to main interface.
  - ◇ Under locked screen status, press this button for 5 seconds to unlock screen.
-  Mode button
  - ◇ Under main interface, press this button to check unit running status.
  - ◇ Hold for 5 seconds to access parameter setting menu.
-  and 
  - ◇ Turn pages up and down to check, modify parameters.
  - ◇ Combining with  to query and change parameters.
  - ◇ Under unit ON status, press  and  to set temperature in current mode.
-  Timer button
  - ◇ Press this button to enter into Timer ON/OFF setting mode, combining with  and  buttons to set 2 groups of Timer ON/OFF.
  - ◇ Hold for 5 seconds to access clock setting menu.

## LCD operation

- Clock settings
  - ◇ Under main operation interface screen, press  for 5 seconds to enter into clock setting interface.
  - ◇ On clock setting interface screen, press  again, the "hour" digit is flashing, then press  and  buttons to modify value for "hour".
  - ◇ After setting "hour" digit, the "minute" digit is flashing, then press  and  buttons to modify value for "minute".

- ◇ After setting "minute" digit, press  or  to confirm clock settings and go back to main operation interface.
- ◇ Under clock setting interface, if there is no any press on buttons within 30 seconds, will automatically confirm current clock settings and go back to main operation interface.

#### ● Timer settings

- ◇ On main operation interface screen, press  to enter into Timer setting interface.
- ◇ Then press  and  to set Timers, there're 2 groups of Timers.
- ◇ When Time 1 is flashing, press  to enter into Timer 1 ON "hour" digit setting which will flash, then press  and  buttons to set value for "hour" digit.
- ◇ After setting Timer 1 ON "hour" digit, press  again to enter into Timer 1 ON "minute" digit which will flash, then press  and  buttons to set value for Time 1 ON "minute" digit.
- ◇ After setting Timer 1 ON "minute" digit, press  again to enter into Timer 1 OFF "hour" digit, the setting way is same as above.
- ◇ When finish setting Timer OFF time, press  again to confirm current Timer settings, and enter into Timer 2 ON/OFF settings, the operation is same as Timer 1 settings, then back to main operation interface.
- ◇ On Timer setting interface screen, press  at any time to confirm current Timer settings and back to main operation interface.
- ◇ On Timer setting interface screen, press  for 5 seconds to cancel current Timer ON/OFF settings.

#### ● Lock and unlock buttons

The keypad will automatically lock after 60 seconds of inactivity. An icon will show on the screen indicating the keypad is locked. To unlock:

- ◇ Press  for 5 seconds, a "buzzer" will sound, buttons will be unlocked.
- ◇ Can lock the buttons in the same way above.

- **Cooling mode**

- ◇ Press  for 5 seconds, can switch different modes: cooling or heating.

- **Forced defrosting**

- ◇ Under unit ON status, press  for 5 seconds to enter into forced defrosting.

- ◇ Press  for 1 seconds until unit turns off, to cancel defrost.

- **Remove error history record**





- ◇ On error history query interface screen, press  and  for 5 seconds to remove error history records.

- **Reset**

- ◇ Under unit OFF status, press  and  for 5 seconds, parameters will resume initial factory default value.

## PARAMETER CHECKING AND ADJUSTMENT









### Unit running status query table

- On main interface, press  to check unit running status, use  and  buttons to check each parameter. Please refer to a list of relevant unit running parameters below.
- Press  to go back to main interface screen.

Code	Parameter Name	Description	Typical Range
A1	Coil temp	Evaporator coil temperature.	(-10)-15℃ (Heat) 35-48℃ (Cool)
A2	Compressor suction gas temp	Refrigerant gas temperature at the inlet of the compressor.	(-10)-15℃ (Heat) 10-25℃ (Cool)
A3	Compressor exhaust gas temp	Refrigerant gas temperature at the outlet of the compressor.	40-80℃ (Heat) 60-95℃ (Cool)
A4	Ambient air temp	Surrounding ambient air temperature.	(-10)-45℃
A5	Outlet water temp	Water temperature at the outlet of the heat pump (return to water tank).	5-60℃
A6	Compressor current	Displays the compressor current (3-Phase units only).	5-10A
A7	Opening of the EEV	Opening angle of the EEV (Electronic Expansion Valve).	10-60
E1-E6	Error code display	Displays up to 6 error codes.	None

### Parameter settings

User parameters (can be adjusted by users.)

- On main interface screen, press  for 5 seconds to enter into user parameter query interface, press  and  buttons to check each parameter. Please refer to the relevant parameter list below.
- On user parameter query interface, press  to enter into parameter setting interface, press  and  buttons to modify parameter value, press  again to save value and go back to user parameter query interface.
- Press  at any time to confirm settings and go back to main operation interface.

Code	Parameter Name	Description	Range	Default
L2	Temperature Differential	Set how much water temp difference to restart heat pump automatically again, i.e. Heat pump will stop heating once water temperature reaching to set water temperature 55°C in heat mode (for instance). If this parameter is set to 5°C, heat pump won't restart until water temperature drops to 50°C.	1-25°C	5°C
L3	Heat Mode Water Temp Set	Set target water temperature when in Heat mode.	5-60°C	55°C
L4	Cool Mode Water Temp Set	Set target water temperature when in Cool mode.	5-32°C	12°C
L5	Compressor Current	Set upper limit of compressor current. There will be an alert if value exceeds this limit. '0' for no detection. (set for 3-phase units only).	0-40A	0
L6	Buzzer	Set buzzer ON or OFF when heat pump goes to an error mode.	0 (off), 1 (on)	1 (on)
L7	Water pump running mode	0 / 1  0: When target water temp reached and the heat pump will shut down, water pump still keeps running. 1: When target water temp reached and the heat pump will shut down, and water pump will stop running.	0 / 1	1

## SYSTEM PROTECTIONS/ ERROR CODES

When an error occurs or the protection mode is set automatically, the wired controller will display an error code as below.

Code	Failure	Possible reasons	Remedy
Er01	Phase dislocation	Wrong connection of live wires	1) Reverse position of 2 live wires(3-Phase units only).
Er02	Phase loss	Live wires loose or without power	1) Check if live wires loose or without power (3-Phase units only).
Er03	Water flow switch failure.	1) Inadequate water flow 2) Water flow switch damaged 3) Main PCB damaged	1) Check the pump 2) Replace the water flow switch 3) Replace the PCB
Er04	Anti-freeze protection in winter	This function occurs when ambient temp is too low.	No action needed
Er05	High pressure protection	1) Inadequate flow rate 2) Uncompressed gas in refrigerant system 3) Overcharge with refrigerant 4) Water temp setting too high 5) Poor connection of pressure switch 6) Pressure switch failure 7) Main PCB damaged	1) Check pump and water control valve 2) Discharge and then recharge the refrigerant. 3) Discharge some refrigerant 4) Set lower water temp 5) Reconnect the switch 6) Replace the pressure switch 7) Replace the PCB
Er06	Low pressure protection	1) Undercharged refrigerant 2) Capillary block 3) Poor connection of pressure switch 4) Pressure switch failure 5) Main PCB damaged	1) Add some refrigerant 2) Replace the capillary 3) Reconnect the switch 4) Replace the pressure switch 5) Replace the PCB
Er09	Communication failure	The control pad and PCB connection failure	Check the wire connection
Er12	Over-high compressor exhaust gas temp protection	1) Refrigerant Undercharged 2) Possible reasons as Er05	1) Add some refrigerant 2) Similar corrections as Er05
Er15	Inlet water temp sensor failure	1) Sensor open circuit 2) Sensor short circuit 3) Main PCB damaged	1) Check the sensor connection 2) Replace the sensor 3) Replace the main PCB
Er16	Coil temp sensor failure	1) Sensor open circuit 2) Sensor short circuit	1) Check the sensor connection



		3) Main PCB damaged	2) Replace the sensor 3) Replace the main PCB
Er18	Compressor exhaust gas temp. sensor failure	1) Sensor open circuit 2) Sensor short circuit 3) Main PCB damaged	1) Check the sensor connection 2) Replace the sensor 3) Replace the main PCB
Er21	Ambient temp sensor failure	1) Sensor open circuit 2) Sensor short circuit 3) Main PCB damaged	1) Check the sensor connection 2) Replace the sensor 3) Replace the main PCB
Er23	Overflow outlet water temp protection under cooling mode	1) Inadequate water flow rate 2) Overflow inlet water temp 3) Main PCB damaged	1) Check the water filter and water circuit (no block) 2) Adjust the setting temp to normal working range 3) Replace the main PCB
Er27	Outlet water temp sensor failure	1) Sensor open circuit 2) Sensor short circuit 3) Main PCB damaged	1) Check the sensor connection 2) Replace the sensor 3) Replace the main PCB
Er29	Compressor suction gas temp sensor failure	1) Sensor open circuit 2) Sensor short circuit 3) Main PCB damaged	1) Check the sensor connection 2) Replace the sensor 3) Replace the main PCB
Er35	Compressor over-high current protection	1) Inadequate water flow rate under heat mode 2) If ambient temp is above 31°C under heat mode 3) If fan motor broken under cool mode	1) Check pump, filter and water circuit (no block) 2) Check ambient/inlet/outlet water temps 3) Check compressor exhaust and suction gas temps 4) Check fan
Er44	Over-low ambient temp protection	This function occurs when ambient temp is too low.	Check if ambient temp is below -10°C.
Er45	Over-high outlet water temp protection under heat mode	1) Inadequate water flow rate 2) Set outlet water temp is too high 3) Outlet water temp sensor or main PCB damaged	1) Check pump, filter and water circuit (no block) 2) Adjust set outlet water temp to normal working range 3) Replace outlet water temp sensor or main PCB

# WIRING DIAGRAM

(CE-H5, CE-H7)

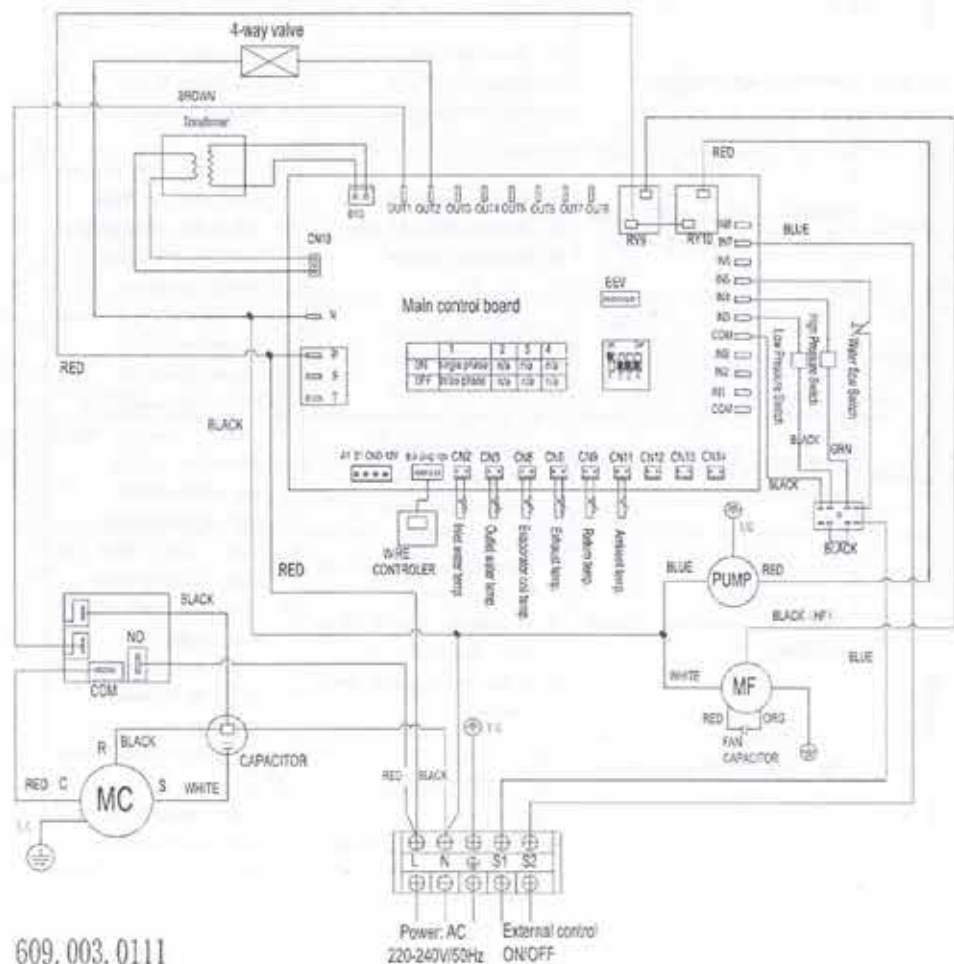



609.003.0111

## INSTALLATION OF THE UNIT

### Installation guidelines

#### Precautions for selecting the location

-  MAKE SURE TO PROVIDE FOR ADEQUATE MEASURES IN ORDER TO PREVENT THAT THE OUTDOOR UNIT WILL BE USED AS A SHELTER FOR SMALL ANIMALS.
  -  SMALL ANIMALS MAKING CONTACT WITH ELECTRICAL PARTS CAN CAUSE MALFUNCTIONS, SMOKE OR FIRE. PLEASE KEEP THE AREA AROUND THE UNIT CLEAN.
1. Choose a place solid enough to bear the weight and vibration of the unit, where the operation noise will not be amplified.
  2. Choose a location where the hot air discharged from the unit or the operation noise will not cause a nuisance to the neighbors of the user.
  3. Avoid places near a bedroom and the like, so that the operation noise will cause no trouble.
  4. There must be sufficient space for carrying the unit into and out of the site.
  5. There must be sufficient space for air passage and no obstructions around the air inlet and the air outlet.
  6. Locate the unit so that the noise and the discharged hot air will not annoy the neighbors.
  7. The site must be free from the possibility of flammable gas leakage in a nearby place.
  8. Install units, power cords and inter-unit cables at least 3m away from television and radio sets. This is to prevent interference to images and sounds.
  9. Depending on radio wave conditions, electromagnetic interference can still occur even if installed more than 3m away.
  10. In coastal areas or other places with salty atmosphere of sulfate gas, corrosion may shorten the life of the outdoor unit.
  11. Since drain flows out of the outdoor unit, do not place anything under the unit which must be kept away from moisture.

#### Selecting a location in cold climates

-  WHEN OPERATING THE OUTDOOR UNIT IN A LOW OUTDOOR AMBIENT TEMPERATURE, BE SURE TO FOLLOW THE INSTRUCTIONS DESCRIBED BELOW.
- To prevent exposure to wind, install the outdoor unit with its suction side facing the wall.
  - Never install the outdoor unit at a site where the suction side may be exposed directly to wind.
  - To prevent exposure to wind, install a baffle plate on the air discharge side of the outdoor unit.
  - In heavy snowfall areas it is very important to select an installation site where the snow will not affect the unit. If lateral snowfall is possible, make sure that the heat exchanger coil is not affected by the snow (if necessary construct a lateral canopy).



Construct a large canopy.

Construct a pedestal.  
Install the unit high enough off the ground  
to prevent burying in snow.

## Installation space

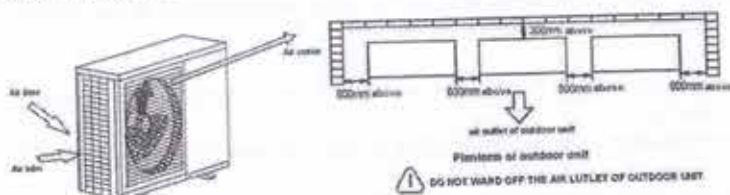

## Mounting the unit

When installing the outdoor unit, please refer to "Installation guidelines" to select an appropriate location.

1. Check the strength and level of the installation ground so that the unit will not cause any operating vibration or noise after installation.
2. Prepare 4 sets of M8 foundation bolts, nuts and washers each (filed supply).
3. Fix the unit securely by means of the foundation bolts in accordance with the foundation drawing. It is best to screw in the foundation bolts until their length remains 20mm above the foundation surface.



## Water pipe work

### Checking the water circuit

The water circuits must be provided by a licensed technician and must comply with all relevant European and national regulations.

 THE UNIT IS ONLY TO BE USED IN A CLOSED WATER SYSTEM. APPLICATION IN AN OPEN WATER CIRCUIT CAN LEAD TO EXCESSIVE CORROSION OF THE WATER PIPING.

Before continuing the installation of the unit, check the following points:

- The maximum water pressure is 6 bar.
- Two stop valves are not delivered with the unit. To facilitate service and maintenance, please install one at each water inlet/outlet. Mind position of the stop valves. Orientation of the integrated drain and fill valves is important for servicing.
- Drain taps must be provided at all low points of the system to permit complete drainage of the circuit during maintenance.
- Air vents must be provided at all high points of the system. The vents should be located at points which are easily accessible for servicing. Do the air purge during the installation.
- Take care that the components installed in the field piping can withstand the water pressure.

### Connecting the water circuit

Water connections must be made in accordance with the outlook diagram delivered with the unit, respecting the water in and outlet



BE CAREFUL NOT TO DEFORM THE UNIT PIPING BY USING EXCESSIVE FORCE WHEN CONNECTING THE PIPING. DEFORMATION OF THE PIPING CAN CAUSE THE UNIT TO MALFUNCTION.

*If air, moisture or dust gets in the water circuit, problems may occur.*

Therefore, always take into account the following when connecting the water circuit:

- Use clean pipes only.
- Hold the pipe end downwards when removing burrs.
- Cover the pipe end when inserting it through a wall so that no dust and dirt can enter.
- Use a good thread sealant for the sealing of the connections.
- The sealing must be able to withstand the pressures and temperatures of the system.
- When using non-brass metallic piping, make sure to insulate both materials from each other to prevent galvanic corrosion.
- Because brass is a soft material, use appropriate tooling for connecting the water circuit. Inappropriate tooling will cause damage to the pipes.



THE UNIT IS ONLY TO BE USED IN A CLOSED WATER SYSTEM. APPLICATION IN AN OPEN WATER CIRCUIT CAN LEAD TO EXCESSIVE CORROSION OF THE WATER PIPING.



NEVER USE ZN-COATED PARTS IN THE WATER CIRCUIT. EXCESSIVE CORROSION OF THESE PARTS MAY OCCUR AS COPPER PIPING IS USED IN THE INTERNAL WATER CIRCUIT OF THE UNIT.



WHEN USING A 3-WAY VALVE OR A 2-WAY VALVE IN THE WATER CIRCUIT. THE RECOMMENDED MAXIMUM CHANGE-OVER TIME OF THE VALVE SHOULD BE LESS THAN 60 SECONDS.

## Charging water

1. Connect the water supply to a drain and fill valve.



### NOTE

- Water quality must be according to EN directive 98/83 EC.

## Piping insulation

The complete water circuit, inclusive all piping, must be insulated to prevent and reduction of the heating capacity.

## Field wiring



### WARNING

- A main switch or other means for disconnection, having a contact separation in all poles, must be incorporated in the fixed wiring in accordance with relevant local and national legislation.
- Switch 'off' the power supply before making any connections.
- All field wiring and components must be installed by a licensed electrician and must comply with relevant European and national regulations.
- The field wiring must be carried out in accordance with the wiring diagram supplied with the unit and the instructions given below.
- Be sure to use a dedicated power supply. Never use a power supply shared by another appliance.
- Be sure to establish an earth. Do not earth the unit to a utility pipe, surge absorber, or telephone earth. Incomplete earth may cause electrical shock.
- Be sure to install an earth leakage protector.

Failure to do so may cause electrical shock.

## Wiring overview

The table below gives a wiring overview of the required field wiring.

Model	CE-H5, CE-H7
Power supply	$\geq 2.0 \text{ mm}^2 \times 3$

## Pre-operation checks

### Checks before initial start-up



SWITCH OFF THE POWER SUPPLY BEFORE MAKING ANY CONNECTIONS.

After the installation of the unit, check the following before switching on the circuit breaker:

**1. Field wiring**

Make sure that the field wiring between the local supply panel and domestic hot water tank has been carried out according to the instructions, according to the wiring diagrams and according to European and national regulations.

**2. Fuses or protection devices**

Check that the fuses or the locally installed protection devices are of the size and type specified. Make sure that neither a fuse nor a protection device has been bypassed.

**3. Earth wiring**

Make sure that the earth wires have been connected properly and that the earth terminals are tightened.

**4. Internal wiring**

Visually check the switch box on loose connections or damaged electrical components.

**5. Fixation**

Check that the unit is properly fixed, to avoid abnormal noises and vibrations when starting up the unit.

**6. Damaged equipment**

Check the inside of the unit on damaged components or squeezed pipes.

**7. Refrigerant leakage**

Check the inside of the unit on refrigerant leakage. If there is a refrigerant leak, call your local dealer.

**8. Power supply voltage**

Check the power supply voltage on the local supply panel. The voltage must correspond to the voltage on the identification label of the unit.

**9. Water flow switch should be installed for the place where there is no constant sufficient water flow (Field supply).**

**10. Stop valves**

Make sure that the stop valves are correctly installed and fully open.



OPERATING THE SYSTEM WITH CLOSED VALVES WILL DAMAGE THE PUMP!

### Setting the pump speed

The pump speed can be selected on the pump. The default setting is high speed (III). If the water flow in the system is too high (e.g., noise of running water in the installation) the speed can be lowered (I or II). The available external static pressure (ESP, expressed in mH<sub>2</sub>O) in function of the water flow (l/min) is shown in the graph below.

### Model RS15/6 and RS25/8

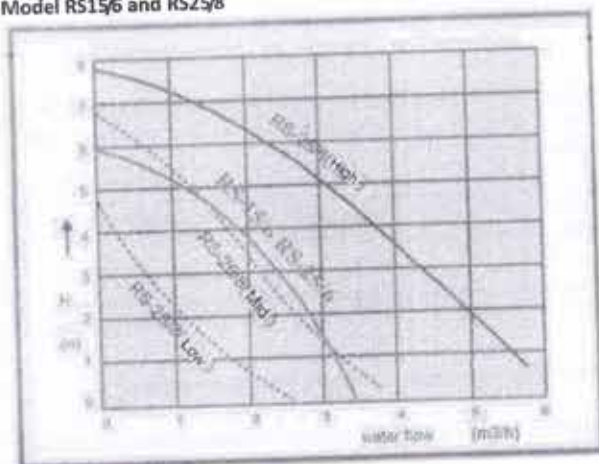



## MAINTENANCE

In order to ensure optimal availability of the unit, a number of checks and inspections on the unit and the field wiring have to be carried out at regular intervals.



BEFORE CARRYING OUT ANY MAINTENANCE OR REPAIR ACTIVITY, ALWAYS SWITCH 'OFF' THE CIRCUIT BREAKER ON THE SUPPLY PANEL, REMOVE THE FUSES OR OPEN THE PROTECTION DEVICES OF THE UNIT.



MAKE SURE THAT BEFORE STARTING ANY MAINTENANCE OR REPAIR ACTIVITIES THE POWER SUPPLY TO THE OUTDOOR UNIT IS SWITCHED 'OFF'.

*The described checks must be executed at least once a year.*

### 1. Water pressure

Check if the water pressure is above 0.3 bar. If necessary add water.

### 2. Domestic hot water tank pressure relief valve (field supply)

*Applies only to installations with a domestic hot water tank.*

Check for a correct operation of the pressure relief valve on the domestic hot water tank.

### 3. Domestic hot water tank booster heater(field supply)

*Applies only to installations with a domestic hot water tank.*

It is advisable to remove lime build up on the booster heater to extend its life span, especially in regions with hard water. To do so, drain the domestic hot water tank, remove the booster heater from the domestic hot water tank and immerse in a bucket (or similar) with lime-removing product for 24 hours.

## TROUBLESHOOTING

This section provides useful information for diagnosing and correcting certain troubles which may occur in the unit.

### General guidelines

Before starting the troubleshooting procedure, carry out a through visual inspection of the unit and look for obvious defects such as loose connections or defective wiring.

Before contacting your local dealer, read this chapter carefully, it will save you time and money.

 WHEN CARRYING OUT AN INSPECTION ON THE SWITCH BOX OF THE UNIT, ALWAYS MAKE SURE THAT THE MAIN SWITCH OF THE UNIT IS SWITCHED "OFF".

When a safety device was activated, stop the unit and find out why the safety device was activated before resetting it. Under no circumstances safety devices may be bridged or changed to a value other than the factory setting. If the cause of the problem cannot be found, call your local dealer/installer.

if the pressure relief valve is not working correctly and needs to be replaced.

## TEMPERATURE SENSOR R-T CONVERSION TABLE

R25 = 5.0K $\Omega$  $\pm$ 1.0%

B25-50 = 3470K $\pm$ 1.0%

T(°C)	Rmin(K $\Omega$ )	R(K $\Omega$ )	Rmax(K $\Omega$ )	T(°C)	Rmin(K $\Omega$ )	R(K $\Omega$ )	Rmax(K $\Omega$ )
-30.0	61.254	63.465	65.749	46.0	2.287	2.328	2.369
-29.0	58.028	60.090	62.219	47.0	2.209	2.250	2.290
-28.0	54.991	56.914	58.898	48.0	2.135	2.174	2.214
-27.0	52.130	53.924	55.773	49.0	2.063	2.102	2.141
-26.0	49.434	51.107	52.832	50.0	1.994	2.032	2.071
-25.0	46.892	48.454	50.063	51.0	1.927	1.965	2.003
-24.0	44.497	45.954	47.455	52.0	1.863	1.901	1.938
-23.0	42.237	43.598	44.998	53.0	1.802	1.839	1.876
-22.0	40.105	41.376	42.682	54.0	1.743	1.779	1.815
-21.0	38.094	39.280	40.499	55.0	1.686	1.721	1.757
-20.0	36.195	37.303	38.441	56.0	1.631	1.666	1.701
-19.0	34.402	35.437	36.499	57.0	1.579	1.613	1.647
-18.0	32.709	33.676	34.668	58.0	1.528	1.561	1.595
-17.0	31.109	32.012	32.939	59.0	1.479	1.512	1.545
-16.0	29.597	30.441	31.306	60.0	1.432	1.464	1.497
-15.0	28.168	28.957	29.765	61.0	1.386	1.418	1.451
-14.0	26.816	27.554	28.308	62.0	1.343	1.374	1.406
-13.0	25.538	26.227	26.932	63.0	1.301	1.331	1.362
-12.0	24.328	24.972	25.631	64.0	1.260	1.290	1.321
-11.0	23.183	23.785	24.400	65.0	1.221	1.250	1.280
-10.0	22.098	22.661	23.236	66.0	1.183	1.212	1.242
-9.0	21.071	21.598	22.135	67.0	1.147	1.175	1.204
-8.0	20.098	20.590	21.093	68.0	1.111	1.139	1.168
-7.0	19.176	19.636	20.106	69.0	1.077	1.105	1.133
-6.0	18.301	18.732	19.171	70.0	1.045	1.072	1.099
-5.0	17.472	17.875	18.285	71.0	1.013	1.040	1.067
-4.0	16.686	17.063	17.446	72.0	0.983	1.009	1.035
-3.0	15.940	16.292	16.650	73.0	0.953	0.979	1.005
-2.0	15.231	15.561	15.896	74.0	0.925	0.950	0.975
-1.0	14.559	14.867	15.180	75.0	0.897	0.922	0.947
0.0	13.920	14.208	14.501	76.0	0.871	0.895	0.919
1.0	13.313	13.582	13.856	77.0	0.845	0.869	0.893
2.0	12.736	12.988	13.244	78.0	0.820	0.843	0.867
3.0	12.188	12.423	12.662	79.0	0.796	0.819	0.842
4.0	11.666	11.887	12.110	80.0	0.773	0.795	0.818
5.0	11.170	11.376	11.585	81.0	0.751	0.773	0.795
6.0	10.698	10.891	11.086	82.0	0.729	0.751	0.773

7.0	10.249	10.429	10.611	83.0	0.708	0.729	0.751
8.0	9.822	9.990	10.160	84.0	0.688	0.709	0.730
9.0	9.414	9.572	9.730	85.0	0.668	0.689	0.709
10.0	9.027	9.173	9.321	86.0	0.649	0.669	0.690
11.0	8.657	8.794	8.932	87.0	0.631	0.651	0.671
12.0	8.305	8.432	8.561	88.0	0.613	0.632	0.652
13.0	7.969	8.088	8.208	89.0	0.596	0.615	0.634
14.0	7.648	7.760	7.872	90.0	0.579	0.598	0.617
15.0	7.343	7.446	7.551	91.0	0.563	0.581	0.600
16.0	7.051	7.148	7.245	92.0	0.548	0.566	0.584
17.0	6.773	6.863	6.953	93.0	0.533	0.550	0.568
18.0	6.507	6.5911	6.675	94.0	0.518	0.535	0.553
19.0	6.253	6.331	6.410	95.0	0.504	0.521	0.538
20.0	6.011	6.083	6.156	96.0	0.490	0.507	0.524
21.0	5.779	5.847	5.914	97.0	0.477	0.493	0.510
22.0	5.558	5.620	5.683	98.0	0.464	0.480	0.496
23.0	5.346	5.404	5.463	99.0	0.452	0.467	0.483
24.0	5.144	5.198	5.252	100.0	0.439	0.455	0.470
25.0	4.950	5.000	5.050	101.0	0.428	0.443	0.458
26.0	4.761	4.811	4.861	102.0	0.416	0.431	0.446
27.0	4.580	4.630	4.680	103.0	0.405	0.420	0.434
28.0	4.408	4.457	4.507	104.0	0.395	0.409	0.423
29.0	4.242	4.292	4.341	105.0	0.384	0.398	0.412
30.0	4.084	4.133	4.182	106.0	0.374	0.388	0.402
31.0	3.933	3.981	4.030	107.0	0.364	0.378	0.391
32.0	3.788	3.836	3.885	108.0	0.355	0.368	0.381
33.0	3.649	3.697	3.745	109.0	0.346	0.358	0.372
34.0	3.516	3.563	3.611	110.0	0.337	0.349	0.362
35.0	3.388	3.435	3.483	111.0	0.328	0.340	0.353
36.0	3.266	3.313	3.360	112.0	0.320	0.332	0.344
37.0	3.149	3.195	3.241	113.0	0.311	0.323	0.336
38.0	3.037	3.082	3.128	114.0	0.303	0.315	0.327
39.0	2.929	2.974	3.019	115.0	0.296	0.307	0.319
40.0	2.826	2.870	2.915	116.0	0.288	0.300	0.311
41.0	2.726	2.770	2.815	117.0	0.281	0.292	0.303
42.0	2.631	2.675	2.718	118.0	0.274	0.285	0.296
43.0	2.540	2.583	2.626	119.0	0.267	0.278	0.289
44.0	2.452	2.494	2.537	120.0	0.260	0.271	0.282
45.0	2.368	2.409	2.451				

## WIFI APPLICATION

### 1. Install APP

Download and install the APP in the "app store" using your computer or mobile phone.



### 2. APP startup

After the installation completed, click on the icon "Smart Life" to start running the APP.





①

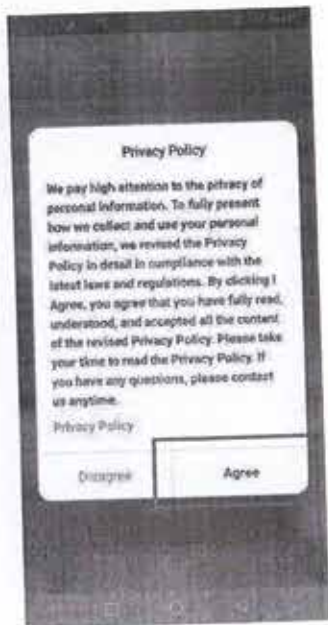

②



3



4



5

Input a family name,  
location, rooms, then  
press " Done ".



6



### 3. Add device

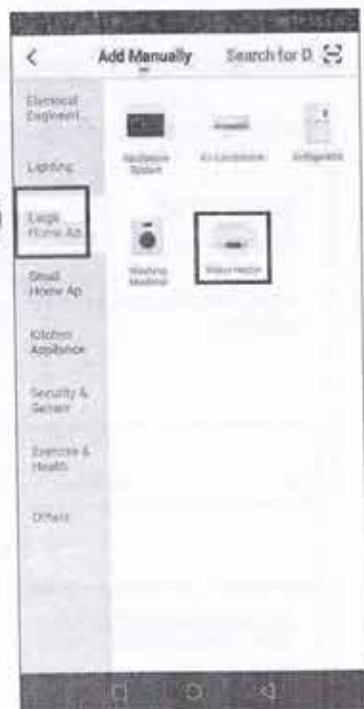

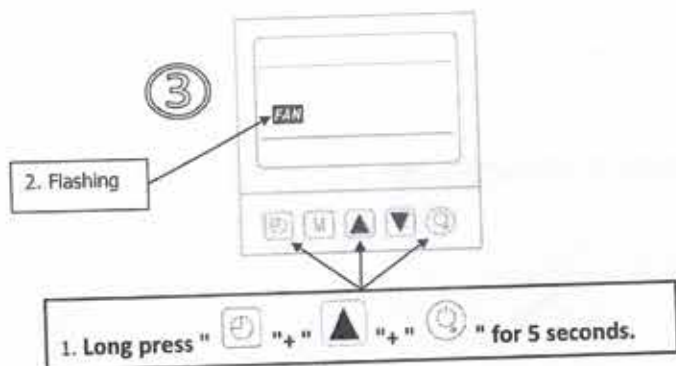

Long press " [Power] "+" [Up Arrow] "+" [Power] " for 5 seconds to enter into network matching mode. When connected successfully, the "FAN" icon will flash quickly.



Device added successfully. Then press "Done" to enter into operation interface.

#### 4. Control

