

**Cool Energy Pro Pool Series**

**Pool Water Heaters**

Version 3.0



# **Installation and Users Guide**

**IMPORTANT SAFETY INSTRUCTIONS**

**READ AND FOLLOW ALL INSTRUCTIONS**

**RETAIN THIS GUIDE FOR FUTURE REFERENCE**

# Cool Energy Pro Pool Series

## Installation and User Guide

### Customer Service

If you have any questions about ordering Air Source Heat Pump replacement parts and products, please get in touch.

### Customer Service and Technical Support

(Open from 9am-4pm Monday- Friday)

**Phone:** 01472 867497

**Email:** [sales@coolenergyshop.com](mailto:sales@coolenergyshop.com)

**Address:** 169-177 Cleethorpe Road, Grimsby, DN31 3AX

**Website:**

---

**[www.coolenergyshop.com](http://www.coolenergyshop.com)**

# Table of Contents

<b>IMPORTANT SAFETY PRECAUTIONS.....</b>	<b>5</b>
Health and Safety (Materials).....	5
Important End User Safety Information.....	6
<b>Section 1.....</b>	<b>7</b>
<b>Introduction.....</b>	<b>7</b>
Product Overview.....	7
General Features.....	7
<b>Section 2.....</b>	<b>8</b>
<b>Installation.....</b>	<b>8</b>
Materials needed for installation.....	8
Specification tables for Units.....	9
Installation of Outdoor Unit.....	10, 11
Suggested Installation Method.....	12
Water Connections.....	13
Plumbing Installation Requirements.....	13
Electrical Connections.....	14
General Information.....	14
Electrical Wiring Diagram.....	15, 16
Power Supply.....	17
Grounding and Over Current Protection.....	17

<b>Section 3.....</b>	<b>18</b>
<b>Operating Heat Pump.....</b>	<b>18</b>
LCD User-Friendly Interface Controller.....	18
General Instruction.....	19
Controller Panel.....	19
Controller Set-up.....	19
1. Temperature Setting.....	19
2. System Status Display Value.....	20
3. Clock Setting.....	21
4. Timer Setting.....	21
5. Manual/Forced Defrosting.....	22
General Operating Guide.....	23
User Guide.....	23
Product Protection.....	24, 25
<b>Section 4.....</b>	<b>26</b>
<b>General Maintenance.....</b>	<b>26</b>
Controller Error Codes.....	26
Inspection and Service.....	27
Owner Inspection.....	27
Trouble Shooting.....	27
Problems and Corrective Action.....	28, 29, 30, 31, 32, 33, 34

---

## HEALTH AND SAFETY INFORMATION

---

### INFORMATION FOR INSTALLER AND SERVICE ENGINEERS

Under the Consumer Protection Act 1987 and the Health and Safety at Work Act 1974, it is required to provide information on substances hazardous to health (COSHH Regulations 1998).

Cool Energy takes every reasonable care to ensure that these products are designed and constructed to meet these general safety requirements, provided they are properly installed and used.

To fulfil this requirement, products are comprehensively tested and examined before dispatch.

When working on the appliance, it is the responsibility of the user/engineer to ensure that any necessary personal protective clothing or equipment is worn when appropriate for parts, which could be considered hazardous or harmful.

This appliance may contain some of the items below:

#### **Refrigerants**

The appliance contains R410a refrigerant. The constituents of R410a are HFC's R134, , HFC-32 and HCF-125 all of which have low toxicity levels.

When handling, avoid inhalation and contact with the skin and eyes. Suitable personal protective equipment (PPE) must be worn (gloves, overalls, eye protection) and a comprehensive first aid kit (containing eyewash) should be easily available.

Site engineers should have a certificate of competence and should know and understand the properties and hazards before handling liquid refrigerants.

When the appliance has come to the end of its life span, an approved engineer must dispose of the equipment and refrigerants in accordance with the EU laws.

Seek urgent medical attention if inhaled or digested. Exposure to eyes and skin should be followed by immediate cleansing of the affected areas and medical attention if necessary.

#### **Insulation**

Fibre insulation may be irritating to the skin, eyes, nose and throat. When handling, avoid inhalation and contact with the eyes. Use disposable gloves, facemasks and eye protection.

After handling, wash hands and other exposed parts. When disposing, reduce dust with water spray and ensure all parts are securely wrapped.

#### **Glue, Sealants and Paints**

Glue, sealants and paints are used in this appliance and present no known hazards when used in the manner of which they are intended.



## IMPORTANT SAFETY INFORMATION FOR THE END-USER

- Installation of the appliance must only be carried out by persons with suitable competence.
- Do not attempt to modify, repair or service the appliance yourself.
- Do not insert body parts or any other items into the air inlet or outlet.
- Do not start or stop the unit by removing the power cable; always use the controls and switches provided.
- If installed outside, ensure the appliance is protected from prolonged exposure to large quantities of water.
- Do not operate the unit or the programmer with wet fingers.
- Keep the programmer unit out of reach of children.
- The electrical supply must be isolated during a heightened risk of lightning strikes.
- Do not attempt to move the appliance once it is installed; this must be carried out by a qualified engineer.
- Isolate the electrical supply to the appliance if an odour presents, or scorching is detected.
- Only use this appliance for the purpose intended.
- Ensure the area around the appliance is clean, well-ventilated and kept free of all obstructions.
- Do not keep items on top of the appliance or use it to support other appliances.
- Do not under any circumstances stand on the appliance.
- Isolate the electrical supply to the appliance if it is to be switched off for a period of more than two months.
- Periodically check the condition of any supports for deterioration.
- Do not wash the unit with water, alcohol, benzene, thinner, glass cleaner or powders.
- During cleaning, isolate the electrical supply to the appliance.

# Section 1

## Introduction

### Product Overview

Air Source Heat Pumps transfer heat from the ambient air to water, providing high-temperature hot water up to 40°C. The unique Cool Energy Pro Pool heat pump is widely used for Swimming Pool, Spa and Pond Heating.

With our innovative & advanced technology, the pro mono block range of heat pumps can operate very well down to -15°C ambient temperature with high output temperatures up to 40°C. Compared with traditional Oil / LPG boilers, Cool Energy heat pumps produces up to 50% less CO<sup>2</sup> whilst saves up to 80% on running costs. Cool Energy heat pumps are not only highly efficient, but also easy and safe to operate.

### General Features

1. Low running costs and high efficiency.
  - A high coefficient of performance (COP) of up to 5, results in lower running costs compared with traditional ASHP technology.
  - No immersion heater supplement is required.
2. Reduced Capital Costs.
  - Simple installation
3. High Comfort Levels.
4. No potential danger of any inflammable, gas poisoning, explosion, fire, electrical shock which are associated with other heating systems.
5. A digital controller is incorporated to maintain the desired water temperature.
6. Long-life and corrosion resistant stainless cabinet stands up to severe climates.
7. The latest compressor technology ensures outstanding performance, ultra-energy efficiency, durability and quiet operation.
8. Self-diagnostic control panel monitors and troubleshoots heat pump operations to ensure safe and reliable operations.
9. Intelligent digital controller with friendly user interface and blue LED back light.
10. Separate isolated electrical compartment prevents internal corrosion and extends heat pump life.
11. The heat pump can operate down to ambient air temperature of -15°C.

## Section 2

# Installation

The following general information describes how to install the air source heat pump.

**Note:** Before installing this product, read and follow all warning notices and instructions. Only a qualified / competent person should install the heat pump.

### Materials needed for Installation:

The following items are needed and are to be supplied by the installer for **all** heat pump installations:

1. Plumping fittings.
2. Level surface with provision for condensate drainage.
3. Ensure that a suitable electrical supply cable is provided. See the rating plate on the heat pump for electrical specifications. Please take a note of the specific current rating. No junction box is needed at the heat pump; Connections are made inside of the heat pump electrical compartment. Conduit may be attached directly to the heat pump jacket.
4. It is advised to use PVC conduit for the electrical supply cables.
5. Ensure correctly sized pipe work to obtain minimum water flow rates required.
6. A filter on the water inlet to the heat pump is required.
7. The plumbing should be insulated to reduce heat losses, and water treated with a suitable inhibited antifreeze.

**Note:** We recommend installing shut-off valves on the inlet and outlet water connections for ease of serviceability.



## Cool Energy Pro Pool Series Air Source Heat Pump Specification

Cool Energy Pool and Pond Air to Water Heat Pumps				
Model		CE-PH7	CE-PH14	CE-PH23
ERP Energy Rating:		A++	A++	A++
Rated Capacity @ 28°C Water/ 20°C Ambient	Heating Capacity	6.77kW	14.09kW	23.49kW
	Power Input	1.25kW	2.52kW	4.8kW
	Coefficient Performance	4.2COP	5.6 COP	4.79 COP
Rated Capacity @ 28°C Water/ 7°C Ambient	Heating Capacity	4.55kW	10.5kW	16.1kW
	Power Input	1kW	2.95kW	3.84kW
	Coefficient Performance	Coefficient	3.55 COP	4.2 COP
Rated Capacity @ 40°C Water/ 20°C Ambient	Heating Capacity	5.85kW	11.05kW	21.3kW
	Power Input	1.3kW	2.64kW	5.28kW
	Coefficient Performance	4.68 COP	4.18 COP	4.32 COP
Rated Capacity @ 40°C Water/ 7°C Ambient	Heating Capacity	4.09kW	9.5kW	14.49kW
	Power Input	1.1kW	3.18kW	4.22kW
	Coefficient Performance	3.72 COP	2.99 COP	3.8 COP
Rated Power Input:		1.2kW/5.5A	3kW/13.63	4.62kW/21A
Max Power Input:		1.79kW/8.15	3.6kW/16.36	5.09kW/23.1
Compressor Make/Model:		Mitsubishi RN145VHEMC	Mitsubishi LN28VBRMC	Copeland ZW54KWP-PFS-52E
Noise:		≤52dB(A)	≤60dB(A)	≤60dB(A)
Power supply:		220-240V AC – 50Hz		
Outlet Water Temperature:		15°C-45°C		
Protection class:		IPX4		
Anti-electric shock class:		Class I		
Refrigerant/Charge:		R410A-800g	R410A-1300g	R410A-3000g
Average Water Flow Required:		4m <sup>3</sup> /h	6m <sup>3</sup> /h	7.5m <sup>3</sup> /h
Pool Volume:		<20m <sup>3</sup>	<42m <sup>3</sup>	<70m <sup>3</sup>
Water Connections:		1 ½" PVC	1 ½" PVC	1 ½" PVC
Climate Type:		-15~43°C		
Product dimension: L x W x H:		mm 725/365/990	755/365/111	830/732/955
Net weight:		59kg	76kg	115kg
Manufacture Date / Serial Number See Bar Code				
<b>Cool Energy Holding Ltd</b> <b>Grimsby, UK</b> <b>01472 867497</b> <b>www.coolenergyshop.com</b>				

**Note:** The above design and specifications are subject to change without prior notice for product improvement. For detailed specifications of the units please refer to name plate on the units. Correct installation is required to ensure safe operation. The requirements for Cool Energy heat pumps include the following:

1. Appropriate site location and clearances.
2. Wiring to conform to 17<sup>th</sup> edition wiring regulations.
3. Adequate water flow.

This manual provides the information needed to meet these requirements. Review all application and installation procedures completely before continuing the installation.

## Installation of Outdoor Unit

The heat pump should be installed on a solid level base that can take the weight, preferably a concrete foundation. If concrete slabs are used, they must rest on asphalt or shingle.



The heat pump should not be positioned next to sensitive walls, for example, next to a bedroom. Also ensure that the placement does not inconvenience the neighbours. The heat pumps must not be placed so that recirculation of the outdoor air can occur; this causes lower output and impaired efficiency.

Large amounts of condensation water as well as melted waters from defrosting can be produced. Condensation water must be led off to a drain, soakaway or similar.

The outdoor unit should be installed in a ventilated place, with enough space for air inlet and outlet, while without thermal radiation or other heat source. The air outlet should not be against the wind.

Generally, horizontal air flow type heat pump does not need sheltering. The structure design has protected all internal components against rain and sunshine. A shelter is necessary to avoid snow burying the heat pump in heavy snow areas.

Please make sure the standardized voltage 220V-240V is available to the heat pump, otherwise the performance would be influenced and could affect your warranty.

The foundation of the heat pump can be a cement or steel structure. Anti-vibration rubber feet and a flat foundation are generally required. The foundation structure can be flexibly designed according to the working weight of the heat pump. (Please see the technical data in this manual.)

Water drainage should be available near the installation location for draining water in an effective way. Do not install the heat pump in a place where there is polluting or corrosive materials like oil, flammable and explosive gas and sulphide ect. Keep it far away from sands, falling leaves and area with high-frequency equipment.

Installation on a balcony or on a roof-top must be in accordance with the allowable stress of the building structure.

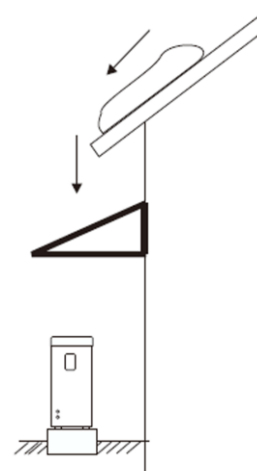

The installation space should be referred as follows:

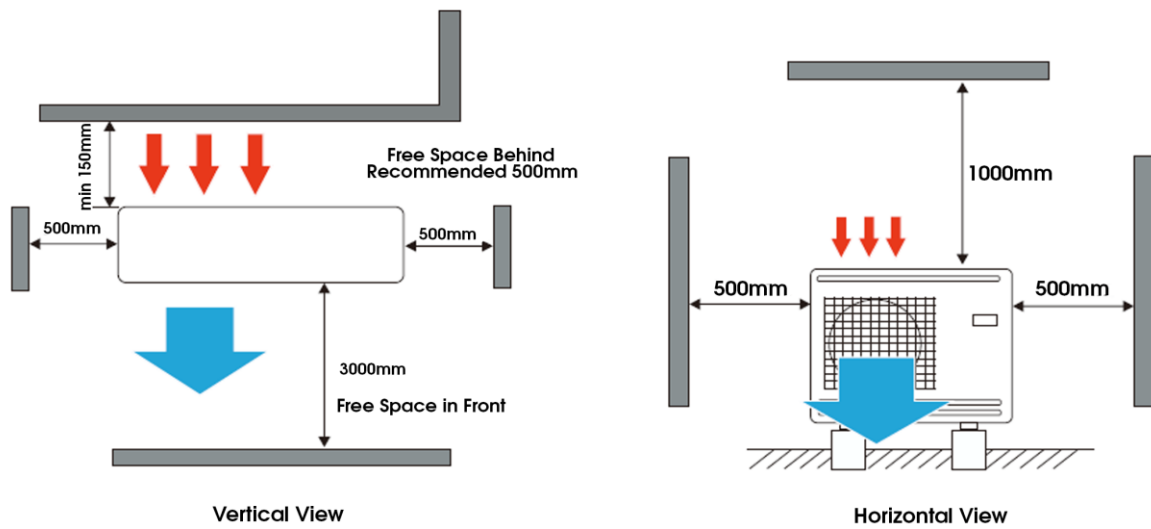

Intake and outlet should not be obstructed. The wall the unit is to be mounted on should be strong enough to bear the weight and vibrations of the unit.

Allow for proper clearances around the unit. Location should allow easy access for maintenance.

For any further guidance on heat pump installations for planning purposes, please consult the latest version of the MCS guidelines or your local authority.

Suggested Installation Method: -

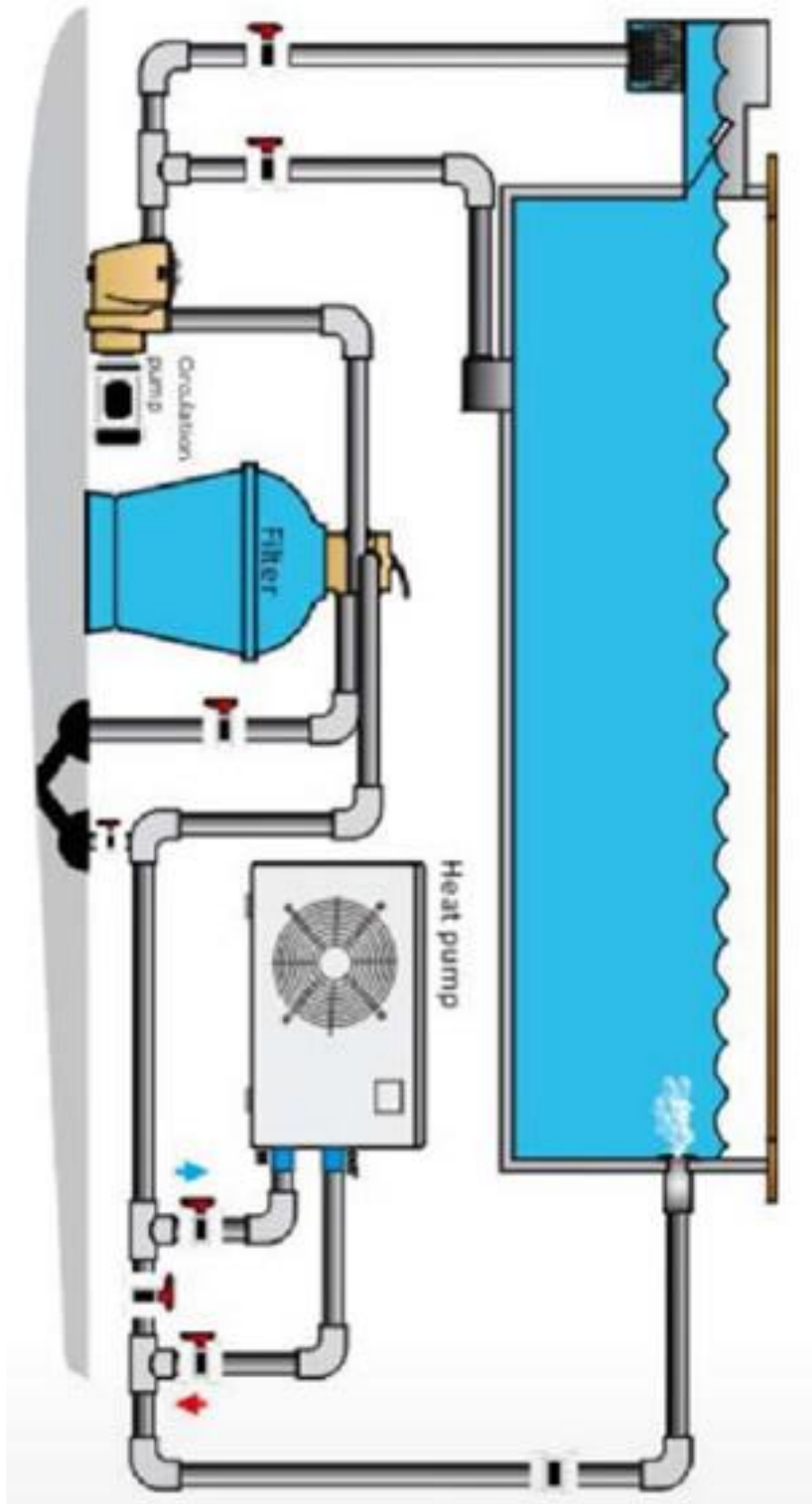

## Water Connections

### Water connections at the heat pump

Flexible pipe fittings are recommended to be installed on the flow and return connections. (See Figure 3).



(Figure 5)

The water inlet and outlet connections to the heat pump, accept standard PVC / ABS fittings.



**CAUTION** – Make sure that the required water flow rates can be maintained at all times.

### Plumbing Installation Requirements

1. Water pressure should not exceed 3 Bar.
2. Each part connected to the unit needs to be connected with method of loose jointing and installed with intermediate valves.
3. Ensure that all plumbing has been properly flushed and tested.
4. All pipelines and pipe fittings must be insulated to prevent heat losses.
5. Install a drain valve at the lowest point of the system to enable the system to be drained fully.
6. Install a check valve on the water outlet connection if back siphoning could occur.
7. In order to reduce the back pressure, the pipes should be installed horizontally.
8. Minimum flow rates detailed on the date badge must be maintained and could void warranty and damage unit if they are not.

## Electrical Connections



**WARNING** – Risk of electrical shock or electrocution.

Ensure that all high voltage circuits are disconnected before commencing heat pump installation. Contact with these circuits could result in death or serious injury to users, installers or others.



**CAUTION** – Label all wires prior to disconnection when servicing the heat pump. Wiring errors can cause improper and dangerous operation. Check and ensure proper operation after servicing.

## General Information

Wiring connections must be done according to the wiring diagram found on the inside of the heat pump access panel or see addendum A for reference.

The heat pumps must also be earthed. A ground lug is provided on the inside of the heat pump electrical compartment.

The supplied controller is pre-wired using a low voltage low loss cable and can be easily moved and located where required.

The controller plugs directly onto the cable supplied with no additional wiring required.

If you wish to extend this cable or any of the sensor cables, please use a shielded low loss cable.

# Wiring Diagrams

## Single Phase: CE- PH7

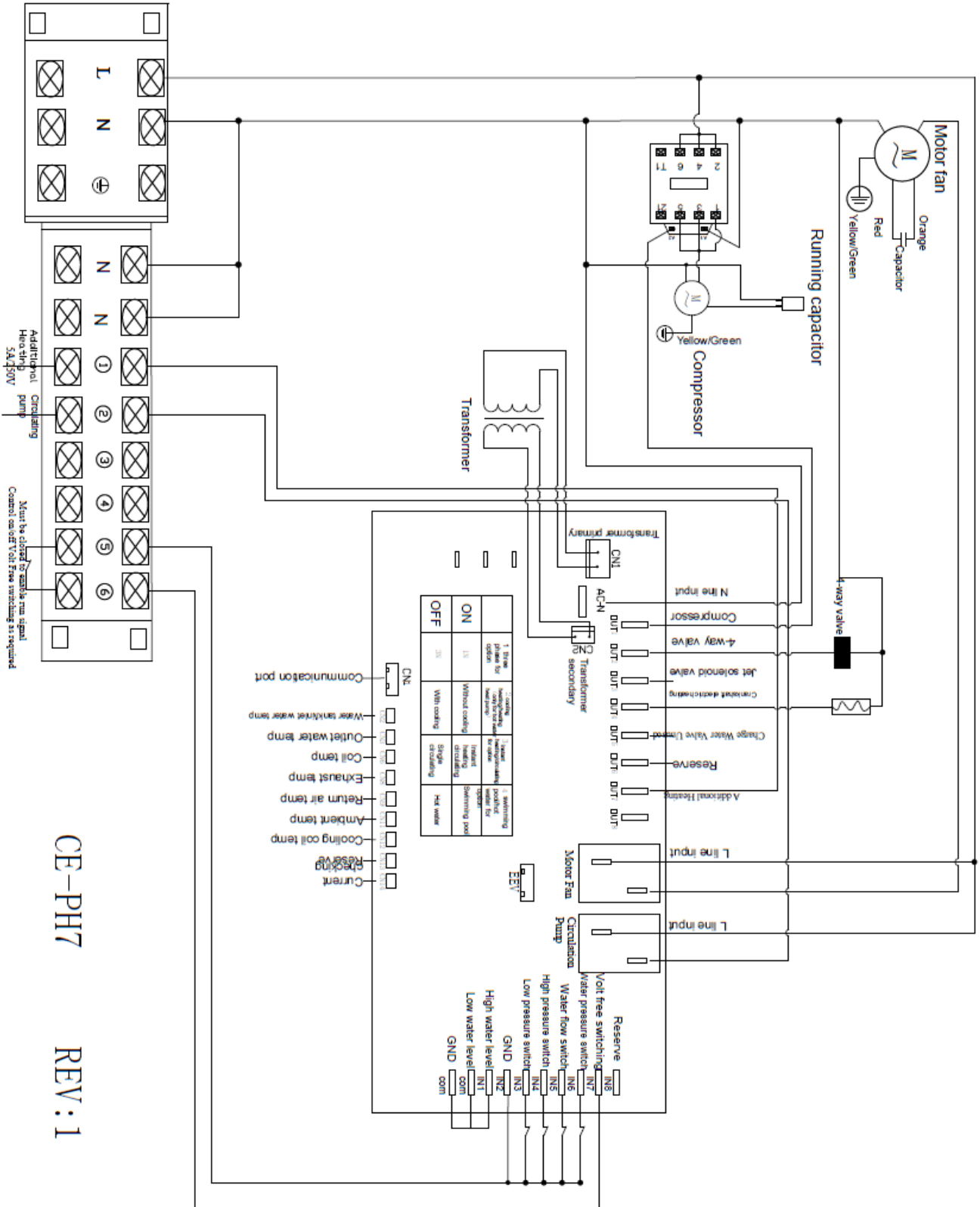

CE-PH7

REV:1

# Single Phase CE- PH14, CE-PH23

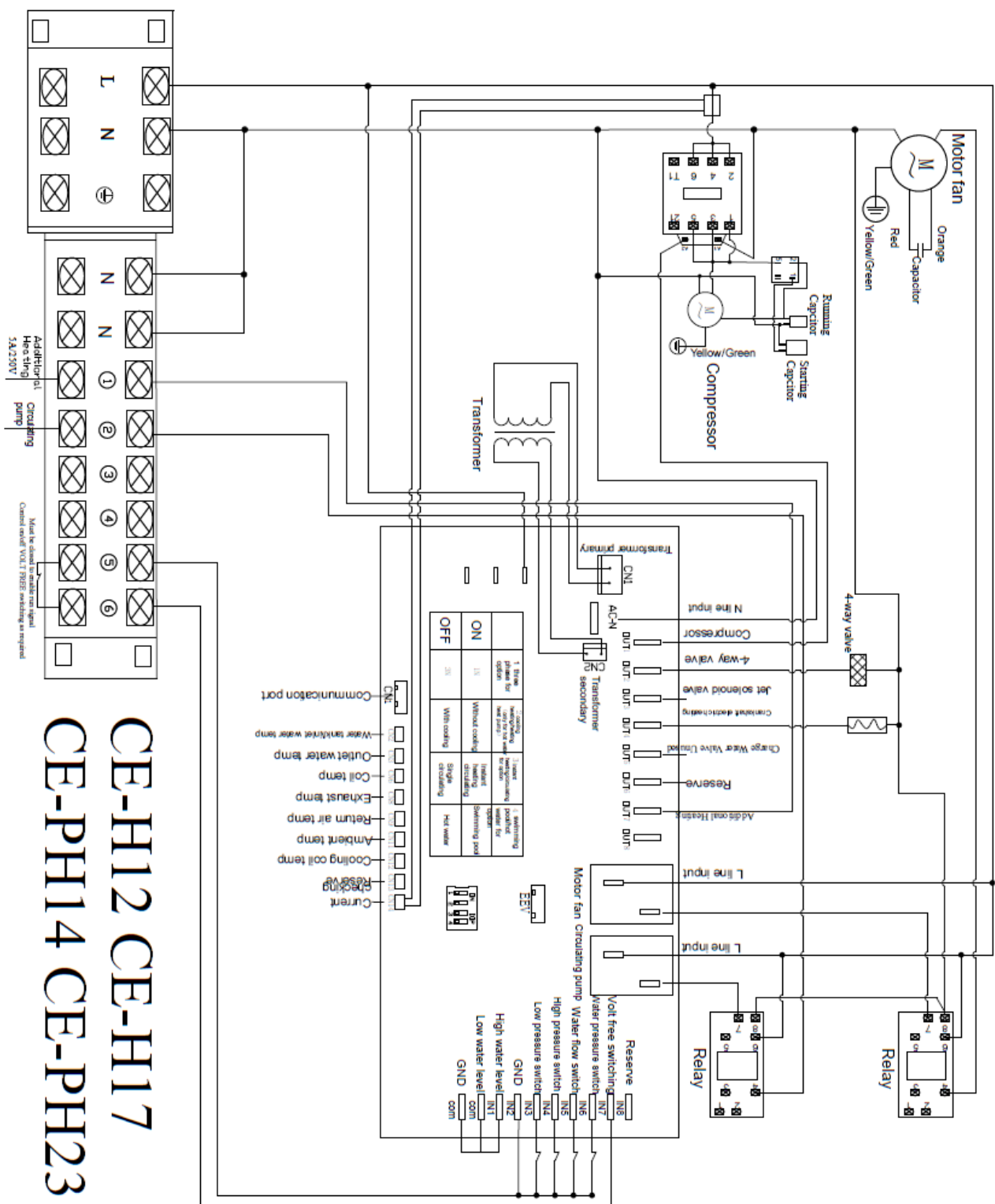

**CE-H12 CE-H17**  
**CE-PH14 CE-PH23 REV 1**



## **Power Supply**

1. If the supply voltage is too low or too high, it can cause damage and/or result in unstable operation of the heat pump unit, due to high inrush currents on start up.
2. The minimum starting voltage should be above 90% of rated voltage. The acceptable operating voltage range should be within  $\pm 10\%$  of the rated voltage. When heat pump units are installed in parallel, ensure that the voltage difference, between these units, is within  $\pm 2\%$  of each other. The voltage difference between phases of a three-phase power supply should be within  $\pm 2\%$ .
3. Ensure the cable specifications meet the correct requirements for the specific installation. The distance between the installation site and the mains power supply will affect the cable thickness. Follow the 17<sup>th</sup> edition wiring regulations to select the cables, circuit breakers and circuit breakers.

## **Earthing and Over Current Protection**

In order to prevent electrical shock in case of leakage from unit, install the heat pump according to current electrical wiring regulations.

1. Do not frequently interrupt the voltage supply to the heat pump as this may result in a shorter life expectancy of the heat pump.
2. When installing over current protection, ensure that the correct current rating is met for this specific installation.
3. The compressor, fan coil unit and heat pump water pump all have AC- contactors and thermo relay protection. Therefore, in the process of installation and debugging, firstly measure each of the components' current, and then adjust the current protection range of the thermo relays.

## Section 3

# Operating Your Heat Pump

### LCD User-Friendly Interface Controller

#### General Instructions

The operation panel features:

1. Capacitive touch keys for higher operating sensitivity and unlimited key operations.
2. Minimal electromagnetic susceptibility and interference.
3. Stylish appearance of easy viewing purposes.
4. Dust and Water Proof.
5. Install on wall indoor for convenient operation.
6. Automatic Key Lock Function (AKL).

#### Controller Panel

#### Operating Controller



#### Operation Guide

When the power supply to the heat pump is switched on for the first time, an audible tone is heard from the controller. The LCD will be displayed in a dimming mode (no back light). At this time the touch keys are locked (see “lock key display” symbol).

## Keys Explanation:

**Unlocking Keys:** Press the “power” key for 3 seconds until you hear the audible tone, then release the key. The backlight of the LCD display will turn on and the key pad is locked with no “lock key display” symbol. The key pad will automatically lock after 60 seconds, displaying the “lock key display” symbol.

**“Power” keys:** By pressing the “power” key for 3 seconds, the unit can be switched ON and OFF.

**“▲” and “▼” keys:** Press to increase and decrease set temperature.

**“M” key:** Press for inquiry, parameter and password setting.

**“Clock” key:** Press for timer setting, timer eliminate and clock settings.

## Controller Set-Up

### 1. Temperature Setting:

Make sure key-pad is unlocked. Press the “▲” key, “temperature setting” symbol is flashing and the set temperature is displayed. Press the “▲” key again, the displayed temperature will increase. Press the “▼” key, “temperature setting” symbol is flashing and the L3 set temperature is displayed. Press the “▼” key again, the displayed temperature will decrease. The range of water temperature can be set from 20°C (68°F) to 40°C (140°F) (default = 40°C (140°F)).



### NOTE:

- It is recommended that the maximum setting temperature to 28°C for pools.

## 2. System Status display values:

Make sure key-pad is unlocked. Press the “M” key and enter into the inquiry panel.



The up and down keys can now be used to view the status of all sensors.

On the state of power on, press the “M” key for more than 3 seconds, until an audible tone is heard and enter into the setting panel. After parameter set, press the “setting” key again to adjust each parameter or the up and down arrows to navigate through the settings. After all parameters set, exit the setting panel by pressing the power key. Details are shown as follows:

Code	Name	Range	Default
L1	Not Used	20°C–40°C	N/A
L2	Decreasing water temperature difference to restart Compressor	3–18°C	5°C
L3	Pool water temperature setting	20°C–40°C	40°C
L4	Not Used	N/A	N/A
L5	Ambient temperature to trigger AUX heating terminal	0°C–35°C	5°C
L6	Not Used	N/A	20
L7	Not Used	N/A	20
L8	Not Used	N/A	0
L9	Not Used	N/A	55

For a single heat pump system (SHPS), the inquiry codes are from A1 to A9. By pressing the “M” key sequentially, the desired inquiry code will be selected, and value displayed. To exit the inquiry panel, press the “Power” key once after the last inquiry code (Er) is reached. Details are shown as follows:

Item	Info	Item	Info
A1	Evaporator coil pipe temp.	A6	Heating inlet water temp.
A2	Compressor suction temp.	A7	N/A
A3	Compressor discharging temp.	A8	N/A
A4	Ambient temp.	A9	EEV opening degree
A5	Water outlet temp.	A10	N/A
C1	Constant temp valve steps for option*10	E1-E6	Last 6 Fault Codes

### 3. Clock Setting

Press the “Clock” key for more than 8 seconds until an audible tone is heard and the clock display flashes. Press the “Clock” key again to adjust hours. The hour value is flashing and can be adjusted by pressing “▲” and “▼” keys. Press the “clock” key for minute adjustment and repeat as previous. Press the “Power” key to exit.



### 4. Timer Setting

The heat pump consists of four separate timing functions. Timer 01 and 02 are used to set the ON/OFF times of the heat pump within the 24-hour period.

#### Heat pump ON/OFF timers:

- 01 – ON/OFF timing
- 02 – ON/OFF timing
- 03 – ON/OFF timing
- 04 – ON/OFF timing

Press the “Clock” key and use up and down key to select 01 ON time. Set the ON time as in **Clock Setting** section. Press the “Clock” key again to set timer 01 OFF time. Set the OFF time as in **Clock Setting** section. Repeat sequence until all timer settings are completed.

If, however, a timer is not used, set ON and OFF times to 00:00. Timer setting can be randomly selected. For example, Timer 01 ON, Timer 02 OFF, Timer 03 OFF and Timer 04 OFF.



After completing all timer settings, the controller will display the following:



### **5. Manual/ Forced Defrosting:**

Although this heat pump features an automatic defrosting function, a manual defrosting function enables the user to manually defrost the heat pump when unusual frosting appears. Make sure the key-pad is unlocked. Ensure that heat pump unit is in running mode, displaying the heat symbol.

Press the “▼” key for more than 8 seconds until an audible tone is heard, and release key. The heat pump will be in defrosting mode and the “defrost” symbol will be on display.

## General Operating Guide

### Initial Start-Up Precautions

First boot-strap and running state checks.

1. To ensure the power to the unit is at the correct voltage.
2. Unit electrical connections: Check if power supply wire connections are okay; if earth wire is properly connected; check if water pump and other chain devices are properly connected.
3. Water pipe and pipes: ensure all pipes have been flushed and are free of debris.
4. Check water system: make sure the water flow is adequate and there is no air or leakages.
5. First boot-strap or starting up again after being shut down for a long time, stop, ensure power is on ahead and heating at least 12 hours for crankcase (local loop temperature is zero). Water pump starts up first, fan starts up, and then compressor starts up and begins regular operation.
6. Running checks: check the following items:
  - a. Input and output water temperature.
  - b. Water flow rate.
  - c. Running electric current of compressor and fan.
  - d. High and low-pressure value when heating is running.

 **CAUTION** – Refrain from using this heat pump if any technical components have been in contact with water. Immediately call a qualified service technician to inspect the heat pump.

 **CAUTION** – Keep all objects clear from above the heat pump. Blocking air flow could damage the unit and may void the warranty.

### Users Guide

#### 1. Rights and Responsibility

1.1 To ensure you have the service guarantee period, only qualified heating engineers can install and repair the unit. If you infract this request and cause any loss and damage, our company will not be held responsible. Please refer to your warranty card for further information.

#### 2. User Guide

2.1 All safety protection devices are set in unit before leaving the factory, don't adjust it by yourself.

2.2 Units have been charged with refrigerant and lubricating oil, if needed owing to a leak; please refer to the charging quantity on nameplate.

2.3 The external water pump must be connected to the output from the unit.

2.4 Use antifreeze / glycol when the environment temperature is less than zero in winter.

2.5 Safety Precautions

- a. Unit must be installed by a competent person, plumber or heating engineer.
- b. Please check that power supply corresponds with unit size.
- c. The main power switch of unit should have earth leakage protector; the power cable must meet the unit power requirements.
- d. Unit must have a ground wire; don't use the unit if there is no ground wire.
- e. Don't use the unit if the fan fence has been removed.

- f. To avoid electric shock or fire, don't store or use, oil paint, petrol, combustible gas or liquid around the unit; don't throw water or other liquid on to the unit and don't touch the unit with wet hands.
- g. Don't adjust the switch, valve, controller or internal data without permission of customer support team.
- h. If a safety protection device is activated at start up, please contact the customer support team.

## Product Protection

**1. Compressor Time Delay Protection:** To ensure the compressor is protected, a time delay of 3 minutes is needed to restart the compressor following it becoming satisfied.

**2. Compressor High Discharge Temperature Production (error code: Er12):** If a high compressor discharge temperature ( $\geq 115\text{C}$  (239F)) is detected for 30 seconds, the heating function will be disabled, and the error code will be displayed. The heat pump will resume operating automatically after 3 minutes.

**4. Compressor High Pressure Protection (error code: Er05):** If a high pressure is detected on the compressor, the heating function will be suspended, the error code will be displayed, and the alarm will sound. The heat pump unit will resume operation 3 minutes after the high pressure switch was rest. If the same error code appears for 3 consecutive times within an hour the heating function will be permanently disabled and the alarm will sound. Please consult an authorised service technician. This error normally relates to an inadequate water flow rate causing the heat pump to overheat, check that the system pipework has been designed to allow the water flow rate required on the data badge.

**5. Compressor Low Pressure Protection (error code: Er06):** If a low pressure is detected on the compressor, the heating function will be suspended, the error code will be displayed, and the alarm will sound. The heat pump unit will resume operation 3 minutes after the high pressure switch was rest. If the same error code appears for 3 consecutive times within an hour, the heating function will be permanently disabled, the error code will be displayed and the alarm will sound. Please consult an authorised service technician.

**NOTE:** Low pressure will not be detected under 2 circumstances, during the defrosting period and/or during the first 5 minutes after the compressor has started.

**6. Sensor (Any) Faults (error codes: Er15, Er16E, Er18, Er21, Er22, Er27, Er29, Er42):** When any sensor appears to be faulty, the heating function will be suspended, and the corresponding error code will be displayed. The heat pump will resume operation when the fault has been corrected.

### 7. Frost Protection:

- During constant temp standby or power off, if ambient temp  $\leq 2^{\circ}\text{C}$ , the unit goes into anti-freeze protection mode 1, circulating water pump every 40mins for 5min. When ambient temperature increases the unit will exit anti-freeze protection mode.
- During constant temp standby or power off, if ambient temp  $\leq 2^{\circ}\text{C}$ , and water tank probe is  $\leq 4^{\circ}\text{C}$ , the unit goes into anti-freeze protection mode 2, automatically heating until water tank temp probe reaches  $\geq 15^{\circ}\text{C}$  or ambient temp  $\geq 8^{\circ}\text{C}$  then the unit will exit



anti-freeze protection mode 2.

- During antifreeze mode the outlet water temp $\leq 2^{\circ}\text{C}$ , warns water pump fault Er04, until the outlet water temp $\geq 4^{\circ}\text{C}$ .
- If there is a water tank temperature probe fault and then ambient temp decides to go into anti-freeze mode, it will only trigger mode 1.
- If there is an ambient temperature probe fault, then the unit automatically goes into mode 1 anti-freeze protection.
- If ambient temperature probe and outlet temperature probe both give a fault, then then the unit will go into mode 1 anti-freeze protection and water pump will function.

## **9. Compressor over Current Protection (Er35): - Not Currently Used**

### **10. Controller Communication Faults (Er09):**

- The first time the unit powers on, if within 20 seconds the PCB doesn't receive communication from remote controller, it will operate to "the last input parameter";
- If when the unit is running, and remote controller doesn't receive communication from PCB for a constant 10 seconds it is judged as a communication fault, the unit will display fault code Er09. During this time the unit works as per original settings and after communication fault is corrected the fault will disappear.

## Section 4

### General maintenance

#### Controller Error Codes

The following Common Error Codes for the heat pump units displayed on the controller:

CODE	NAME	CODE	NAME
Er01	Phase Failure	Er21	Ambient temperature too low and/or Faulty ambient temperature sensor
Er02	Phase Stagger	Er22	Faulty heating inlet water sensor
Er04	Anti-freeze Protection	Er23	Cooling supercool protection
Er05	Compressor high pressure discharge	Er24	Constant temperature sensor fault
Er06	Compressor low pressure and/or faulty switch	Er27	Faulty outlet water temp sensor
Er09	Controller communication fault	Er29	Faulty compressor suction temp sensor
Er11	Password protection	Er35	Compressor over current protection
Er12	Compressor high discharge temperature	Er37	Inlet / outlet water temp differential too high much protection
Er15	Faulty inlet water tank water temperature sensor	Er42	Cooling coil sensor fault
Er16	Faulty Evaporator sensor	Er44	Ambien temperature too low protection
Er18	Abnormal compressor discharge temperature and/or Faulty compressor discharge temperature sensor	Er45	Cooling coil temperature fault

#### NOTE:

If a fault occurs during normal heat pump operation, a common error code will be displayed on the controller display panel. Follow the instructions in Section 3, Controller Set-Up, "System status display values (2)" to "inquire" (check) the specific error codes for the corresponding heat pump systems.

## Inspection and Service

Cool Energy air source heat pumps are designed and built to provide long life and performance, when installed and operated properly under normal conditions. Periodic inspections are important to keep your heat pump running safely and efficiently.

### Owner Inspection

Cool Energy recommends that inspections on heat pumps are done frequently, especially after abnormal weather conditions. The following basic guidelines are suggested for your inspection:

1. Make sure the front of the unit is accessible for service.
2. Keep the top and surrounding areas of the heat pump clear of all debris.
3. Keep all plants and shrubs trimmed and away from the heat pump especially the area around the fan.
4. Keep lawn sprinklers from spraying on the heat pump to prevent corrosion and damage.
5. Ensure that the earth wire is always properly connected.
6. A water filter must be installed and maintained.
7. All the safety protection devices have been set up; please refrain from changing these settings. If any changes are needed, please contact our support team.
8. If the heat pump is installed under roof without a gutter, ensure that all measures are taken to prevent excessive water from entering the unit.
9. Do not use this heat pump if any electrical part has been in contact with water. Contact an authorized service technician.

## Troubleshooting

Use the following troubleshooting information to resolve issues with your heat pump.



### **WARNING — RISK OF ELECTRICAL SHOCK OR ELECTROCUTION.**



Ensure that all high voltage circuits are disconnected before commencing heat pump installation maintenance. Contact with these circuits could result in death or serious injury to users, installers or others.

- Keep your hands and hair clear of the fan blades to avoid injury.
- **DO NOT** attempt to adjust or service the unit without consulting your authorized installer/agent.
- **PLEASE** read the complete Installation and/or User's Guide before attempting to operate service or adjust the heater.

### Problem and Corrective Action

NO.	Problem Description	Possible Cause	Corrective Action	
1	Error code 01 or 02	1. Absent phase or phase rotation or voltage imbalance among the 3 phases	1. Ensure that incoming phase rotation is correct. Use a phase rotation meter to check incoming phase.	
			2. Test for absent phase, make sure that the circuit breakers are switched ON and check cable connection.	
			3. Test for Voltage imbalance, if not balanced, check cabling and connections.	
		2. Controller or PC Board Faulty (Phase rotation Protection damaged)	Replace the PC Board and/or Controller	
2	Error code 03	1. Water Flow Switch Faulty	Replace Water Flow Switch	
			If no flow switch installed, check flow switch terminal has been linked out.	
		2. Connection cable damaged or disconnected.	Replace the connection cable or reconnect the cable.	
		3. Controller or PC Board Faulty	Replace the PC Board and/or the Controller.	
3	Error code 05	1. Measured water tank water Temp < Actual water tank water Temp	a) The water tank water temperature sensor and PC Board are not compatible.	Use the correct sensor.
			b) The water tank temperature sensor is not in the correct position.	Position the sensor correctly.
		2. The Y shaped filter is blocked.	Clean the filter.	
		3. The plumbing is blocked.	Repair or replace the plumbing and/or valves.	
		4. Too much air in the plumbing result in reduction in flow rate.	1. Remove air from the system.	
			2. Make sure that the circulation pump is working correctly.	
		5. Circulation pump faulty.	a) Circulation pump damaged.	Repair or replace circulation pump.

			b) Circulation pump is too small.	Install correct circulation pump for specific application.
		6. Excessive refrigerant charge volume.		Charge the correct volume of refrigerant specified on the label.
		7. Control cable of the high pressure switch damaged or disconnected.		Replace the damaged cable or reconnect.
		8. High pressure switch cannot be reset.		Replace high pressure switch.
		9. Input of the high pressure sensor is shorted with common, error code 05 is still displaying.		Replace the PC Board.
		10. The refrigeration system is blocked (by ice or dirt).		Find the cause of blockage and replace the filter and/or re-vacuum the system.
4	Error code 06	1. Refrigerant leakage.		Detect leakage and repair. Vacuum, charge refrigerant and start heat pump.
		2. Control cable of the high pressure switch damaged or disconnected.		Replace the damaged cable or reconnect.
		3. Low pressure switch cannot be reset.		Replace low pressure switch.
		4. Input of the high pressure sensor is shorted with common, error code 05E is still displaying.		Replace the PC Board.
		5. The refrigeration system is blocked (by ice or dirt).		Find the cause of blockage and replace the filter and/or re-vacuum the system.
5	Error Code 09	1. The controller cable damaged or disconnected.		Replace damaged controller cable or reconnect.
6	Error Code 11	1. Incorrect installer/agent control password.		Input the correct control password.
7	Error Code 12	1. Insufficient refrigerant charge volume.		Charge the correct volume of refrigerant specified on the label.
		2. Compressor discharge temperature sensor faulty or damaged.		Replace the compressor discharge temperature sensor.
		3. PC Board damaged.		Replace the PC Board.
8	Error Code 15	1. Water tank water temperature sensor		Replace water tank water temperature sensor.

		damaged.	
		2. Water tank water temperature sensor connector (plug) disconnected and/or oxidized due to damp or water.	Reconnect or clean water tank water temperature sensor.
		3. The controller and/or PC Board faulty or damaged.	Replace the controller or PC Board.
9	Error Code 16	1. Defrost temperature sensor faulty or damaged.	Replace the defrost temperature sensor.
		2. Defrost temperature sensor connector (plug) disconnected and/or oxidized due to damp or water.	Reconnect or clean defrost temperature sensor.
		3. The controller and/or PC Board faulty or damaged.	Replace the controller or PC Board.
10	Error code 18	1. Compressor discharge temperature sensor faulty or damaged.	Replace the compressor discharge temperature sensor.
		2. Compressor discharge temperature sensor connector (plug) disconnected and/or oxidized due to damp or water.	Reconnect or clean compressor discharge temperature sensor.
		3. The controller and/or PC Board faulty or damaged.	Replace the controller or PC Board.
11	Error code 21	1. Ambient temperature sensor faulty or damaged.	Replace the Ambient temperature sensor.
		2. Ambient temperature sensor connector (plug) disconnected and/or oxidized due to damp or water.	Reconnect or clean Ambient temperature sensor.
		3. The controller and/or PC Board faulty or damaged.	Replace the controller or PC Board.
12	Error code 22	1. Return water temperature sensor faulty or damaged.	Replace the return water temperature sensor.
		2. Return water temperature sensor connector (plug) disconnected and/or oxidized due to damp or water.	Reconnect or clean Return water temperature sensor.
		3. The controller and/or PC Board faulty or damaged.	Replace the controller or PC Board.
13	Error code 27	1. Outlet water temperature sensor faulty or damaged.	Replace the outlet water temperature sensor.

		2. Outlet water temperature sensor connector (plug) disconnected and/or oxidized due to damp or water.	Reconnect or clean outlet water temperature sensor.	
		3. The controller and/or PC Board faulty or damaged.	Replace the controller or PC Board.	
14	Error code 29	1. Compressor suction temperature sensor faulty or damaged.	Replace the Compressor suction temperature sensor.	
		2. Compressor suction temperature sensor connector (plug) disconnected and/or oxidized due to damp or water.	Reconnect or clean compressor suction temperature sensor.	
		3. The controller and/or PC Board faulty or damaged.	Replace the controller or PC Board.	
15	Error code 31	1. Water pressure switch connector (plug) disconnected and/or oxidized due to damp or water.	Reconnect or clean water pressure cable connection to PC Board.	
		2. Water pressure switch cable damaged.	Replace the cable	
		3. The controller and/or PC Board faulty or damaged.	Replace the controller or PC Board.	
16	Error code 35	1. Compressor over current	1. Check if the incoming voltage.	
			2. Check if the compressor is overloaded.	
			1. Check whether the thermal relay is damaged, if so, replace.	
17	The heat pump is not heating	1. User's incorrect operation and/or parameter settings.	a) The water tank water temperature setting is set too low and the desired temperature cannot be reached.	Re-set the water tank water temperature to the correct range.
			b) The difference between the required water tank water temperature and the heat pump restart temperature (L2) is too big.	Re-set by reducing the value of L2.
			c) Timer function has been set to a specific ON and OFF time, which does not allow sufficient time for the heat pump to operate.	Re-set the timer.
			d) No electrical power supply to the heat pump (no display on the controller).	1. Check and ensure that circuit breakers are ON. 2. Test voltage on the PC Board L/N/E

				Connectors.			
				3. If power is not restored, replace cable.			
				a) The temperature displayed is more than 45°C. Check the water tank water temperature sensor, replace if faulty.			
				b) PC Board is damaged due to burnt relays. Find out the cause, find faulty relay(s) and replace.			
2. Problem with controller or PC Board.				c) PC Board microcontroller chip faulty. Replace the PC Board.			
				18	Slow increase of water tank water temperature	1. Insufficient refrigerant.	1. Check for leakages, if found, repair and re-charge refrigerant as per volume specification on label.
							2. If no leakage was found, re-charge refrigerant as per volume specification on label.
2. The heating capacity of the heat pump is insufficient.	Increase the size or number of heat pump units.						
3. Serious residues/dirt occurred on the heat exchanger.	Clean the heat exchanger.						
4. The evaporator coil is dirty or jammed and this will affect the heat exchange efficiency.	Clean the evaporator coil.						
5. The length of the pipes is too long and/or improperly insulated.	1. If the length of the pipes cannot be reduced, then ensure well insulated piping.						
	2. Increase the size and number of heat pump units.						
19	The controller displays "Er09"	1. The controller cable damaged or disconnected.	Reconnect or replace controller cable.				
		2. PC board damaged.	Replace PC Board.				
		3. Pool temperature sensor and/or cable disconnected or damaged.	Reconnect or replace pool temperature sensor.				
20	No display on the controller	1. Mains power supply is abnormal.	a) The main power supply cables is disconnected or damaged.	Reconnect or replace the mains power supply cable.			



			b) The main power supply voltage is lower than 175V.	Check and ensure that the mains power supply cable', length and thickness, is within the specifications.
		2. PC board power cable is disconnected or the fuse is burnt.	Reconnect PC Board cable or replace the fuse.	
		3. PC Board transformer is damaged.	Replace the PC Board transformer.	
		4. The controller cable damaged or disconnected.	Reconnect or replace controller cable.	
		5. PC Board damaged.	Replace the PC board.	
21	The fan does not operate	1. Fan motor capacitor damaged (under this circumstance the fan motor will overheat).	Replace fan motor capacitor.	
		2. The motor windings have been burnt.	Repair or replace the fan motor.	
		3. The display is ON but heat pump unit is not in running mode/ON.	Press the power button and turn On the heat pump unit.	
		4. Fan motor relay damaged.	Check and replace if damaged.	
		5. No fan motor output from PC Board.	Replace PC board.	
		6. Fan motor cable disconnected or damaged.	Reconnect or replace fan motor cable.	
22	The compressor does not operate while the fan is working	1. Compressor damaged (under this circumstance the compressor motor will overheat).	Replace compressor capacitor.	
		2. Compressor connecting cable is burnt.	Replace compressor connecting cable.	
		3. The compressor windings have been burnt.	Repair or replace the compressor.	
		4. The compressor is jammed or blocked.	Repair or replace the compressor.	
		5. AC contactor does not work.	a) The AC contactor winding is damaged or the contactor is jammed and cannot close.	Replace the AC contactor.

			b) The main power supply voltage is lower than 175V.	Check and ensure that the mains power supply cable', length and thickness, is within the specifications.
			c) No compressor relay output from the PC Board.	Check and/or replace compressor relay or PC Board.
		6. Thermal relay damaged.	Replace the thermal relay.	
23	Frost or ice	1. Fan is not working.	Refer to " <b>problem description #22</b> ".	
		2. Insufficient refrigerant or the refrigeration system is blocked.	1. Find the cause of blockage and replace the filter and/or re-vacuum the system.	
			2. Check for leakages, if found, repair and re-charge refrigerant as per volume specification on label.	
			3. If no leakage was found, re-charge refrigerant as per volume specification on label.	
		3. The defrost parameter is not set correctly.	Re-set the defrost parameter to the correct value.	
		4. The defrost sensor is not placed correctly.	Move the defrost sensor to the correct position.	
		5. The 4-way valve cannot be reversed	Check the 4-way valve to find the cause, replace the winding or the 4-way valve.	
		6. Controller is damaged.	Replace the controller.	
7. The refrigeration system has a problem.	Check and repair refrigeration system.			



**Cool Energy Holding Ltd.**

169-177 Cleethorpe Road,

Grimsby,

DN31 3AX.

Email: [sales@coolenergyshop.com](mailto:sales@coolenergyshop.com)

**[www.coolenergyshop.com](http://www.coolenergyshop.com)**