

**Cool Energy Inverter Monoblock Series
Heat Pump Water Heaters**

Version 5



Installation and Users Guide

**IMPORTANT SAFETY INSTRUCTIONS
READ AND FOLLOW ALL INSTRUCTIONS**

RETAIN FOR FUTURE REFERENCE

Customer Service and Technical Support

(Open from 9am-4pm Monday- Friday)

Phone: 01472 867497

Email: sales@coolenergyshop.com

Address: Office & Showroom - 163 Cleethorpe Road, Grimsby, DN31 3AX

Website: www.coolenergyshop.com

Table of Contents

- IMPORTANT SAFETY PRECAUTIONS..... 3**
 - Health and Safety (Materials)..... 3
 - Important End User Safety Information..... 4

- Section 1..... 5**
- Introduction..... 5**
 - Product Overview..... 5
 - General Features..... 6
- Section 2..... 7**
- Installation..... 7**
 - Materials needed for installation..... 7
 - Installation of Outdoor Unit.....7, 8
 - Suggested Installation Methods.....9, 10, 11
 - Water Connections..... 12
 - Plumbing Installation Requirements..... 12
 - Electrical Connections..... 13
 - General Information..... 13
 - Electrical Wiring Diagram..... 14, 15
 - Power Supply..... 16
 - Grounding and Over Current Protection..... 16

- Section 3..... 17**
- Operating Heat Pump.....17**
 - LCD User-Friendly Interface Controller..... 18
 - General Instruction..... 18
 - Controller Panel..... 18
 - Controller Set-up.....18
 - 1. Temperature Setting..... 19
 - 2. System Status Display Value..... 19
 - 3. Clock Setting..... 19
 - 4. Timer Setting..... 19
 - 5. Manual/Forced Defrosting..... 19
- General Operating Guide..... 20
- User Guide..... 20
- Product Protection..... 21

- Section 4..... 22**
- General Maintenance..... 22**
 - Controller Error Codes..... 22
 - Inspection and Service..... 23
 - Owner Inspection..... 23
- Section 5..... 24**
 - Benchmark.....24**
 - Commissioning Checklist.....24
 - Service Record.....25

HEALTH AND SAFETY INFORMATION

INFORMATION FOR INSTALLER AND SERVICE ENGINEERS

Under the Consumer Protection Act 1987 and the Health and Safety at Work Act 1974, it is required to provide information on substances hazardous to health (COSHH Regulations 1998).

Cool Energy takes every reasonable care to ensure that these products are designed and constructed to meet these general safety requirements, provided they are properly installed and used.

To fulfil this requirement, products are comprehensively tested and examined before dispatch.

When working on the appliance, it is the responsibility of the user/engineer to ensure that any necessary personal protective clothing or equipment is worn when appropriate for parts, which could be considered hazardous or harmful.

This appliance may contain some of the items below:

Refrigerants

The appliance contains R410a refrigerant. The constituents of R410a are HFC's R134, , HFC-32 and HCF-125 all of which have low toxicity levels.

When handling, avoid inhalation and contact with the skin and eyes. Suitable personal protective equipment (PPE) must be worn (gloves, overalls, eye protection) and a comprehensive first aid kit (containing eyewash) should be easily available.

Site engineers should have a certificate of competence and should know and understand the properties and hazards before handling liquid refrigerants.

When the appliance has come to the end of its life span, an approved engineer must dispose of the equipment and refrigerants in accordance with the EU laws.

Seek urgent medical attention if inhaled or digested. Exposure to eyes and skin should be followed by immediate cleansing of the affected areas and medical attention if necessary.

Insulation

Fibre insulation may be irritating to the skin, eyes, nose and throat. When handling, avoid inhalation and contact with the eyes. Use disposable gloves, facemasks and eye protection.

After handling, wash hands and other exposed parts. When disposing, reduce dust with water spray and ensure all parts are securely wrapped.

Glue, Sealants and Paints

Glue, sealants and paints are used in this appliance and present no known hazards when used in the manner of which they are intended.



IMPORTANT SAFETY INFORMATION FOR THE END-USER

- Installation of the appliance must only be carried out by persons with suitable competence.
- Do not attempt to modify, repair or service the appliance yourself.
- Do not insert body parts or any other items into the air inlet or outlet.
- Do not start or stop the unit by removing the power cable; always use the controls and switches provided.
- If installed outside, ensure the appliance is protected from prolonged exposure to large quantities of water.
- Do not operate the unit or the programmer with wet fingers.
- Keep the programmer unit out of reach of children.
- The electrical supply must be isolated during a heightened risk of lightning strikes.
- Do not attempt to move the appliance once it is installed; this must be carried out by a qualified engineer.
- Isolate the electrical supply to the appliance if an odour presents, or scorching is detected.
- Only use this appliance for the purpose intended.
- Ensure the area around the appliance is clean, well-ventilated and kept free of all obstructions.
- Do not keep items on top of the appliance or use it to support other appliances.
- Do not under any circumstances stand on the appliance.
- Isolate the electrical supply to the appliance if it is to be switched off for a period of more than two months.
- Periodically check the condition of any supports for deterioration.
- Do not wash the unit with water, alcohol, benzene, thinner, glass cleaner or powders.
- During cleaning, isolate the electrical supply to the appliance.

Section 1

Introduction

Product Overview

Air Source Heat Pumps transfer heat from the ambient air to water, providing high-temperature hot water up to 60°C. The unique Cool Energy heat pump is widely used for house heating or hot water.

With our innovative & advanced technology, the pro mono block range of heat pumps can operate very well down to -15°C ambient temperature with high output temperatures up to 60°C. Compared with traditional Oil / LPG boilers, Cool Energy heat pumps produces up to 50% less CO² whilst saves up to 80% on running costs. Cool Energy heat pumps are not only highly efficient, but also easy and safe to operate.

General Features

1. Low running costs and high efficiency.
 - A high coefficient of performance (COP) of up to 5, results in lower running costs compared with traditional ASHP technology.
 - No immersion heater supplement is required.
2. Reduced Capital Costs.
 - Simple installation
 - Compatible with traditional radiator systems, under floor heating or fan coils.
3. High Comfort Levels.
 - High storage temperature results in increased hot water availability.
4. No potential danger of any inflammable, gas poisoning, explosion, fire, electrical shock which are associated with other heating systems.
5. A digital controller is incorporated to maintain the desired water temperature.
6. Long-life and corrosion resistant composite cabinet stands up to severe climates.
7. The latest compressor technology ensures outstanding performance, ultra-energy efficiency, durability and quiet operation.
8. Self-diagnostic control panel monitors and troubleshoots heat pump operations to ensure safe and reliable operations.
9. Intelligent digital controller with friendly user interface and blue LED back light.
10. Separate isolated electrical compartment prevents internal corrosion and extends heat pump life.
11. The heat pump can operate down to ambient air temperature of -15°C.

Section 2

Installation

The following general information describes how to install the air source heat pump.

Note: Before installing this product, read and follow all warning notices and instructions. Only a qualified / competent person should install the heat pump.

Materials needed for Installation:

The following items are needed and are to be supplied by the installer for **all** heat pump installations:

1. Plumbing fittings.
2. Level surface with provision for condensate drainage.
3. Ensure that a suitable electrical supply cable is provided. See the rating plate on the heat pump for electrical specifications. Please take a note of the specific current rating. No junction box is needed at the heat pump; Connections are made inside of the heat pump electrical compartment. Conduit may be attached directly to the heat pump jacket.
4. It is advised to use PVC conduit for the electrical supply cables.
5. Ensure correctly sized pipe work to obtain minimum water flow rates required.
6. A filter on the water inlet to the heat pump is required.
7. The plumbing should be insulated to reduce heat losses, and water treated with a suitable inhibited antifreeze.

Note: We recommend installing shut-off valves on the inlet and outlet water connections for ease of serviceability.

Note: For detailed specifications of the units please refer to name plate on the units. Correct installation is required to ensure safe operation. The requirements for Cool Energy heat pumps include the following:

1. Appropriate site location and clearances.
2. Wiring to conform to 17th edition wiring regulations.
3. Adequate water flow.

This manual provides the information needed to meet these requirements. Review all application and installation procedures completely before continuing the installation.

Installation of Outdoor Unit

The heat pump should be installed on a solid level base that can take the weight, preferably a concrete foundation. If concrete slabs are used, they must rest on asphalt or shingle.



The heat pump should not be positioned next to sensitive walls, for example, next to a bedroom. Also ensure that the placement does not inconvenience the neighbours. The heat pumps must not be placed so that recirculation of the outdoor air can occur; this causes lower output and impaired efficiency.

Large amounts of condensation water as well as melted waters from defrosting can be produced. Condensation water must be led off to a drain, soakaway or similar.

The outdoor unit should be installed in a ventilated place, with enough space for air inlet and outlet, while without thermal radiation or other heat source. The air outlet should not be against the wind.

Generally, horizontal air flow type heat pump does not need sheltering. design has protected all internal components against rain and sunshine. necessary to avoid snow burying the heat pump in heavy snow areas.

Please make sure the standardized voltage 220V-240V is available to the otherwise the performance would be influenced and could affect your The foundation of the heat pump can be a cement or steel structure. rubber feet and a flat foundation are generally required. The foundation flexibly designed according to the working weight of the heat pump. technical data in this manual.)

Water drainage should be available near the installation location for an effective way. Do not install the heat pump in a place where there is corrosive materials like oil, flammable and explosive gas and sulphide away from sands, falling leaves and area with high-frequency

Installation on a balcony or on a roof-top must be in accordance with the allowable stress of the building structure.

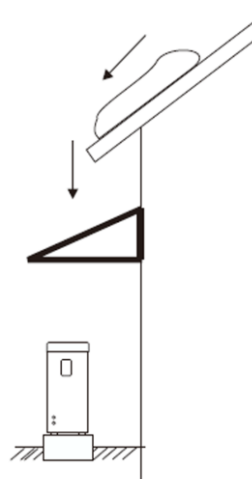

The structure
A shelter is

heat pump,
warranty.
Anti-vibration
structure can be
(Please see the

draining water in
polluting or
ect. Keep it far
equipment.

The installation space should be referred as follows:

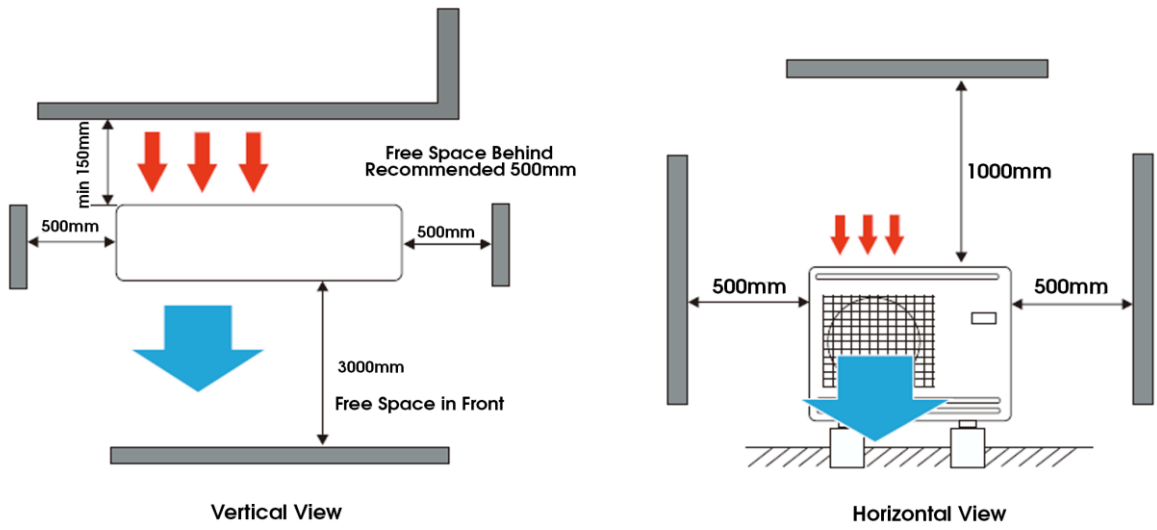

Intake and outlet should not be obstructed. The wall the unit is to be mounted on should be strong enough to bear the weight and vibrations of the unit.

Allow for proper clearances around the unit. Location should allow easy access for maintenance.

For any further guidance on heat pump installations for planning purposes, please consult the latest version of the MCS guidelines or your local authority.

Suggested Installation Method 1: - Heating with Hot Water Priority + Buffer

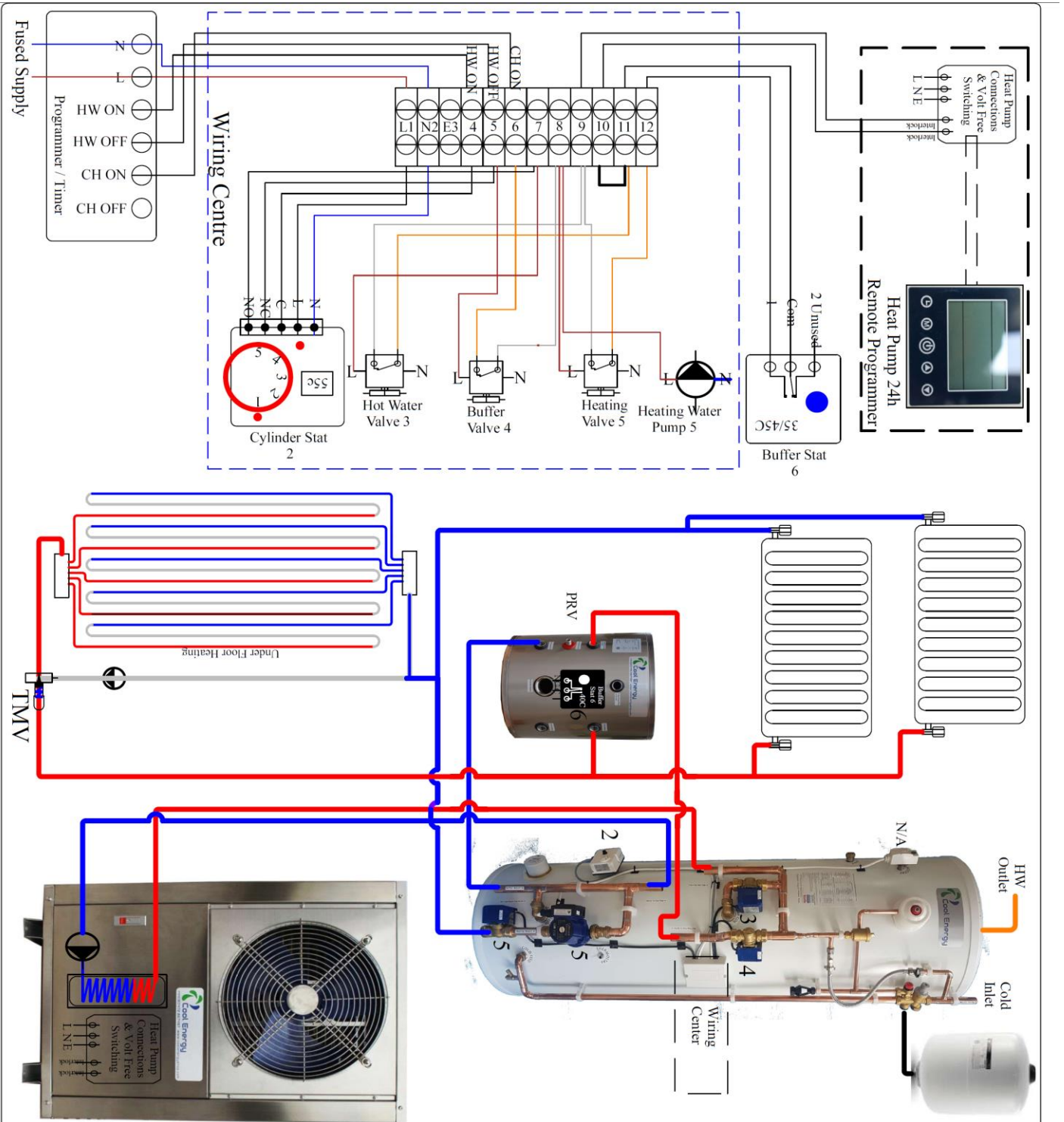

Notes*

- Heat Pump Supplied with
- Programmer Module (24hr Timer)
 - Programmer Cable
 - Internal Water Pump for Heating System
 - Volt Free Switching Terminals
 - Temperature Sensor Probe (Attache to Return in this scenario)

Note*** Below 10kw use minimum 22mm pipe work between Heat Pump, Hot Water Cylinder & the Buffer Tank. Above 10kw use minimum 28mm

Note*** Do not apply voltage to the volt free connections as it will blow the PCB

Note*** Ensure the minimum stated water flow is assured through the Heat Pump heat exchanger when running

Note*** Please observe frost protection requirements & install antifreeze

Note*** Blank Unused Connections on the Buffer Tank

Note*** It is recommended to install strategically placed service valves

Note*** Power requirement

- CE-H6 (10 amp can be 13amp plug)
- CE-H8 (10 amp can be 13amp plug)
- CE-H12 (20 amp type D breaker)
- CE-H17 (32 amp type D breaker)
- CE-Hi6-18 (32 amp type D breaker)
- CE-H17-3ph (16 amp MCB type C)
- CE-Hi6-18-3ph (16 amp MCB type C)

Date: 11/3/2019 REV3

Heating with Hot Water Priority-Buffer

Suggested Installation Method 2: - Hot Water / Buffer / Thermal Store Only

Hot Water Only / Buffer CH-B60 / Thermal Store

Note*** this arrangement can be with or without coil in the tank for Buffer / Thermal Store

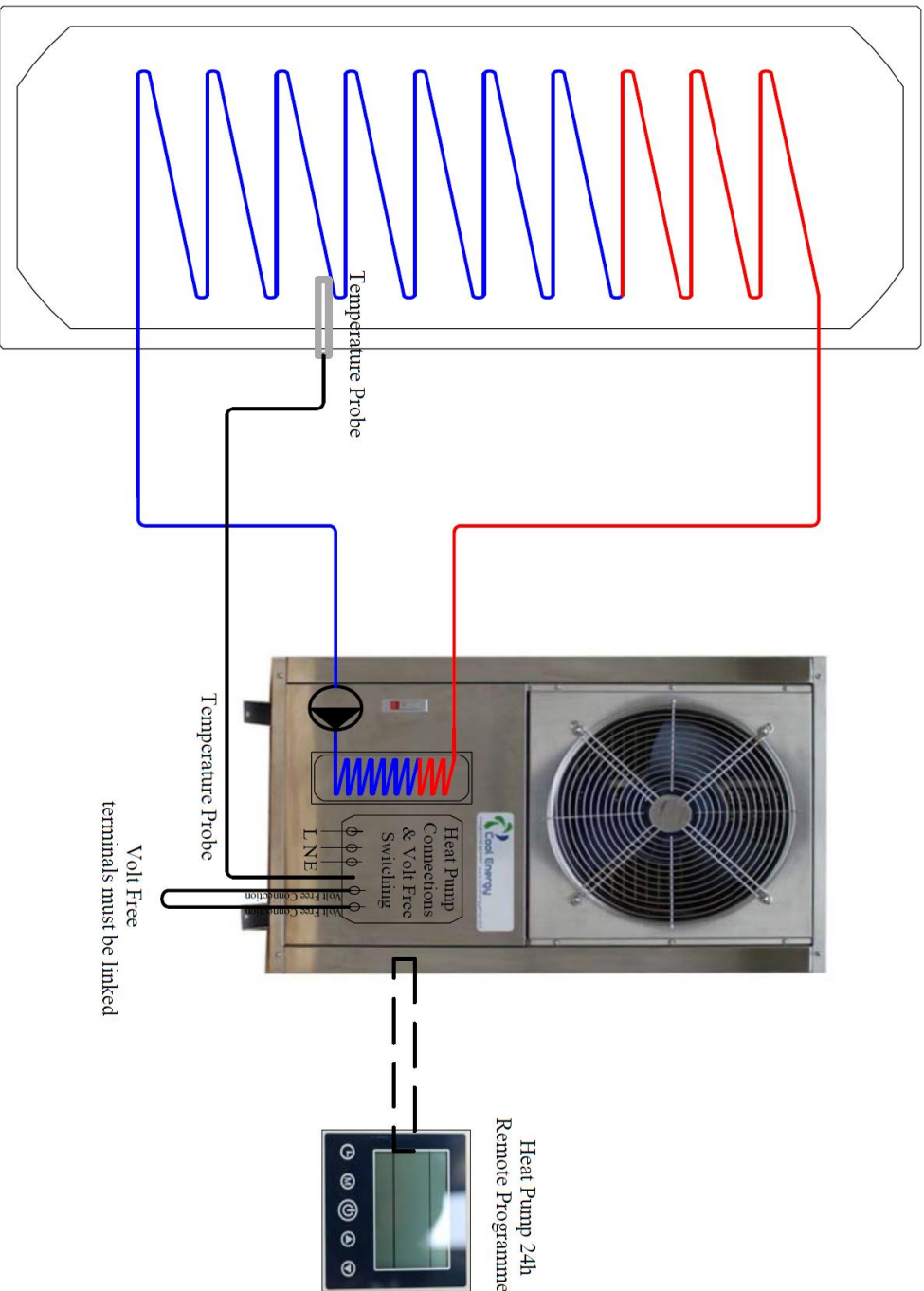

Notes *

- Heat Pump Supplied with
- Programmer Module (24hr Timer)
 - Programmer Cable
 - Internal Water Pump for Hot Water
 - Volt Free Switching Terminals
 - Temperature Sensor Probe (Attached to tank at desired location)

Note*** Below 10kw use minimum 22mm pipe work between Heat Pump & Cylinder. Above 10kw use minimum 28mm

Note*** Do not apply voltage to the volt free connections as it will blow the PCB

Note*** Ensure the minimum stated water flow is assured through the Heat Pump heat exchanger when running

Note*** Please observe frost protection requirements & install antifreeze

Note*** It is recommended to install strategically placed service valves

Note*** Power requirement

- CE-H6 (10 amp MCB can be 13amp plug)
- CE-H8 (10 amp MCB can be 13amp plug)
- CE-H12 (20 amp MCB type C)
- CE-H17 (32 amp MCB type C)
- CE-Hi6-18 (32 amp MCB type C)
- CE-HI7-3ph (16 amp MCB type C)
- CE-Hi6-18-3ph (16 amp MCB type C)

Date: 03-01-2018 REV 1

Hot Water Only with Cylinder

Suggested Installation Method 3: - Heating Only with Buffer

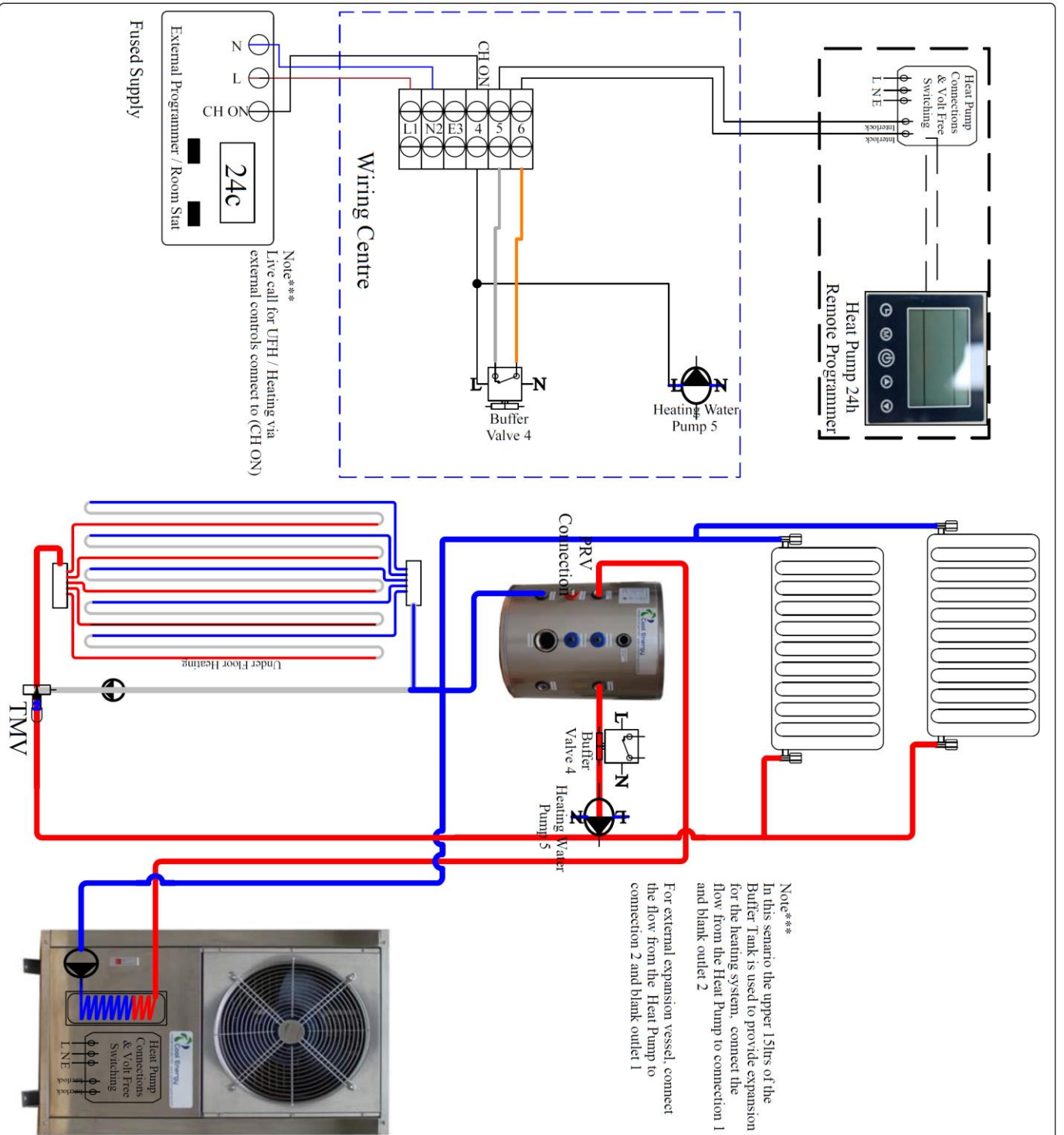

Notes*

- Heat Pump Supplied with
- Programmer Module (24hr Timer)
- Programmer Cable
- Internal Water Pump for Heating System
- Volt Free Switching Terminals
- Temperature Sensor Probe (Attached to the return pipe or Buffer)

Note*** Below 10kw use minimum 22mm pipework between Heat Pump, Hot Water Cylinder & the Buffer Tank. Above 10kw use minimum 28mm

Note*** Do not apply voltage to the volt free connections as it will blow the PCB

Note*** Ensure the minimum stated water flow is assured through the Heat Pump heat exchanger when running

Note*** Please observe frost protection requirements & install antifreeze

Note*** Blank unused connections on the Buffer Tank

Note*** It is recommended to install strategically placed service valves

Note*** Power requirement

- CE-H6 (10 amp MCB can be 13amp plug)
- CE-H8 (10 amp MCB can be 13amp plug)
- CE-H12 (20 amp MCB type C)
- CE-H17 (32 amp MCB type C)
- CE-Hi6-18 (32 amp MCB type C)
- CE-H17-3ph (16 amp MCB type C)
- CE-Hi6-18-3ph (16 amp MCB type C)

Date: 03-01-2018 REV 1

Heating only with Buffer

Water Connections

Water connections at the heat pump

Flexible pipe fittings are recommended to be installed on the flow and return connections. (See Figure 3).



The water inlet and outlet connections to the heat pump, accept standard BSP threaded fittings.



CAUTION – Make sure that the required water flow rates can be maintained at all times.

Plumbing Installation Requirements

1. Water pressure should not exceed 3 Bar.
2. Each part connected to the unit needs to be connected with method of loose jointing and installed with intermediate valves.
3. Ensure that all plumbing has been properly flushed and tested.
4. All pipelines and pipe fittings must be insulated to prevent heat losses.
5. Install a drain valve at the lowest point of the system to enable the system to be drained fully.
6. Install a check valve on the water outlet connection if back siphoning could occur.
7. In order to reduce the back pressure, the pipes should be installed horizontally.
8. Install an automatic bypass valve when connecting directly to a system (no buffer).
9. Minimum flow rates detailed on the date badge must be maintained and could void warranty and damage unit if they are not.

Electrical Connections

 **WARNING** – Risk of electrical shock or electrocution.

Ensure that all high voltage circuits are disconnected before commencing heat pump installation. Contact with these circuits could result in death or serious injury to users, installers or others.

 **CAUTION** – Label all wires prior to disconnection when servicing the heat pump. Wiring errors can cause improper and dangerous operation. Check and ensure proper operation after servicing.

General Information

Wiring connections must be done according to the wiring diagram found on the inside of the heat pump access panel or see addendum A for reference.

The heat pumps must also be earthed. A ground lug is provided on the inside of the heat pump electrical compartment.

The supplied controller is pre-wired using a low voltage low loss cable and can be easily moved and located where required.

The controller plugs directly onto the cable supplied with no additional wiring required.

If you wish to extend this cable or any of the sensor cables, please use a shielded low loss cable.

Wiring Diagrams

Single Phase: CE-iH6-18

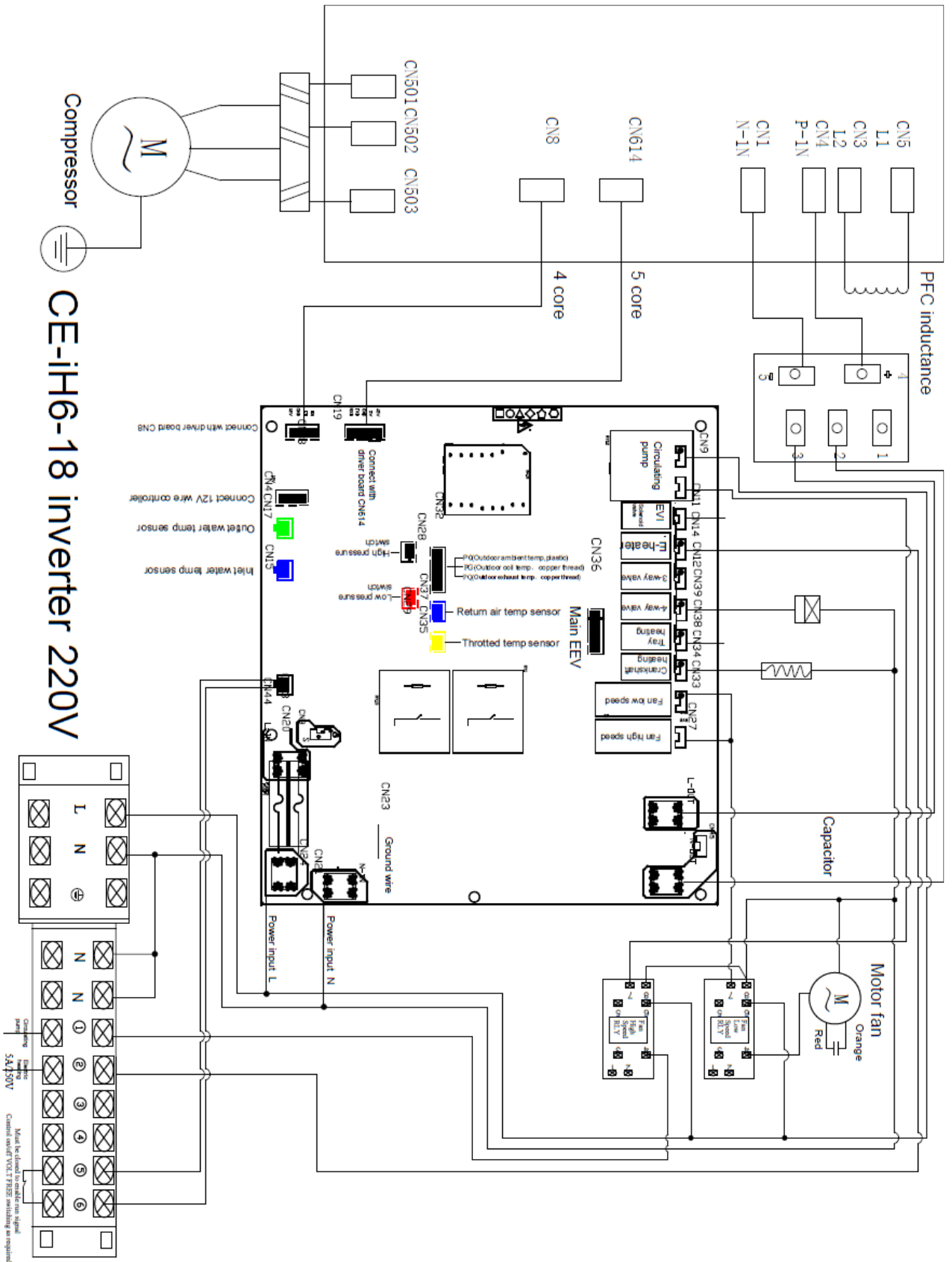

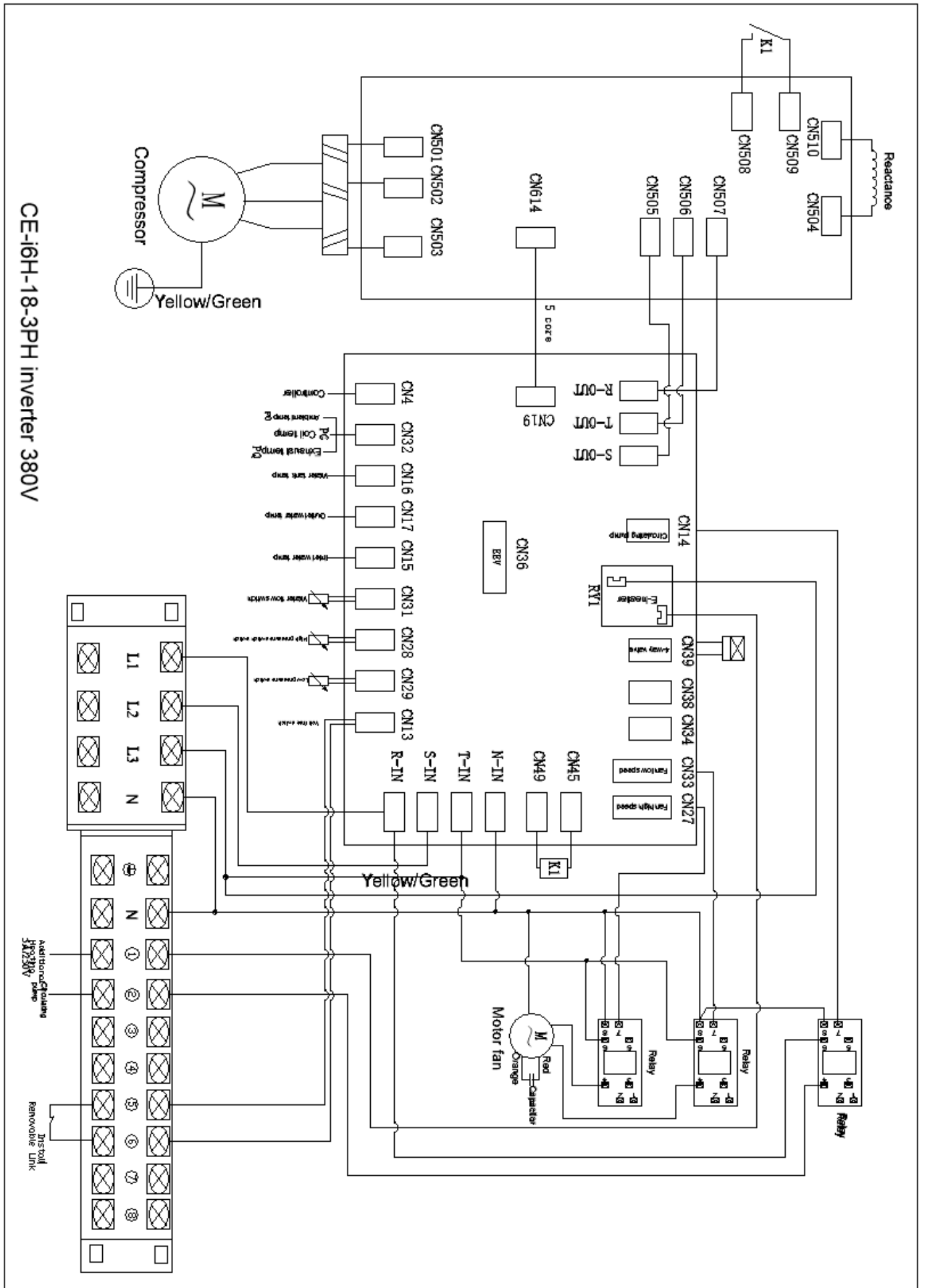

Power Supply

1. If the supply voltage is too low or too high, it can cause damage and/or result in unstable operation of the heat pump unit, due to high inrush currents on start up.
2. The minimum starting voltage should be above 90% of rated voltage. The acceptable operating voltage range should be within $\pm 10\%$ of the rated voltage. When heat pump units are installed in parallel, ensure that the voltage difference, between these units, is within $\pm 2\%$ of each other. The voltage difference between phases of a three-phase power supply should be within $\pm 2\%$.
3. Ensure the cable specifications meet the correct requirements for the specific installation. The distance between the installation site and the mains power supply will affect the cable thickness. Follow the 17th edition wiring regulations to select the cables, circuit breakers and circuit breakers.

Earthing and Over Current Protection

In order to prevent electrical shock in case of leakage from unit, install the heat pump according to current electrical wiring regulations.

1. Do not frequently interrupt the voltage supply to the heat pump as this may result in a shorter life expectancy of the heat pump.
2. When installing over current protection, ensure that the correct current rating is met for this specific installation.
3. The compressor, fan coil unit and heat pump water pump all have AC- contactors and thermo relay protection. Therefore, in the process of installation and debugging, firstly measure each of the components' current, and then adjust the current protection range of the thermo relays.

Section 3

Operating Your Heat Pump

LCD User-Friendly Interface Controller

General Instructions

The operation panel features:

1. Capacitive touch keys for higher operating sensitivity and unlimited key operations.
2. Minimal electromagnetic susceptibility and interference.
3. Stylish appearance of easy viewing purposes.
4. Dust and Water Proof.
5. Install on wall indoor for convenient operation.
6. Automatic Key Lock Function (AKL).

Controller Panel



Operating Controller





Operation Guide

When the power supply to the heat pump is switched on for the first time, an audible tone is heard from the controller. The LCD will be displayed in a dimming mode (no back light). At this time the touch keys are locked (see “lock key display” symbol).

Keys Explanation:

Unlocking Keys: Press the  key for 3 seconds until you hear the audible tone, then release the key. The backlight of the LCD display will turn on and the key pad is locked with no “lock key display” symbol . The key pad will automatically lock after 60 seconds, displaying the “lock key display” symbol .

 **Power keys:** By pressing the “power”  key for 3 seconds, the unit can be switched ON and OFF.

“” and “” keys: Press to increase and decrease set temperature.



“M” key: Press for inquiry, parameter and password setting.

“Clock” key: Press for timer setting, timer eliminate and clock settings.

Press the  key to save the setting and return to the main screen.

Controller Set-Up

1. Temperature Setting:

Make sure key-pad is unlocked. Press the “” key, “temperature setting will change on the Left which is the set temperature. Press the “” key again, the displayed temperature will increase. Press the “” key and the displayed temperature will decrease. The range of water temperature can be set from 30°C (68°F) to 60°C (140°F) (default = 60°C (140°F)).

NOTE:

- It is recommended that the maximum setting temperature to 60°C

2. System Status display values:

Make sure key-pad is unlocked. Press the “M” key and enter into the inquiry panel.

The up and down keys can now be used to view the status of all sensors.

On the state of power on, press the “M” key for more than 3 seconds, until an audible tone is heard and enter into the setting panel. After parameter set, press the “setting” key again to adjust each parameter or the up and down arrows to navigate through the settings. After all parameters set, exit the setting panel by pressing the power key.

Details are shown as follows:

Code	Name	Range	Default
P1	Water tank temperature setting	20°C–60°C	55°C
P2	Not Used	N/A	40°C
P3	Not Used	N/A	10°C
P4	Restart temperature difference	3°C–15°C	5°C
P5	Not Used	N/A	3°C
P6	Displayed temperature difference	0°C–6°C	2
P7	Electric Heating (Hybrid Function)	0 – On / 1 - Off	0 - Auto
P12	Defrosting Mode	0 / 1	1
P13	Defrost Mode Enter Temp	-15°C–2°C	-4°C
P14	Defrost Exit Temp	8°C–20°C	15°C
P15	Defrost Interval Time	25-70min	40min
P16	Defrost Exit Time	2-20min	12min



Status Checking

Press “” and “” for 3s enter status checking interface, with “” & “” key to choose value. Shortly

press “” to exit status interface.

- d01. Frequency
- d02. Current value
- d03. Return water temp
- d04. Water tank temp
- d05. Supply water pipe temp
- d06. Reserve
- d07. Outdoor exhaust temp
- d08. Outdoor ambient temp
- d09. Outdoor coil temp
- d10. Return air temp
- d11. Throttled temp
- d12. EEV opening(display real opening)
- d13. Protection code
- d14. Closing code
- d15. Closing time(the last time closing,min)
- d16. Outdoor motor fan speed
- d17. Target frequency
- d18. EVI EEV opening(display real opening)
- d19. IPM module temperature
- d20. WIFI connection status:0 no connection,3 connecting AP,4 connected AP,5 connected to cloud service

3. Clock Setting

Press the “” key for more than 5 seconds until an audible tone is heard and the clock display flashes. Press the “Clock” key again to adjust hours. The hour value is flashing and can be adjusted by pressing “” and “” keys. Press the “clock” key for minute adjustment and repeat as previous. Press the “Power” key to exit.

4. Timer Setting

The heat pump consists of two separate timing functions. Timer 01 and 02 are used to set the ON/OFF times of the heat pump within the 24-hour period.

Heat pump ON/OFF timers:

01 – ON/OFF timing

02 – ON/OFF timing

Press the “” key and use up and down key to select 01 ON time. Set the ON time as in **Clock Setting** section.

Press the “” key again to set timer 01 OFF time. Set the OFF time as in **Clock Setting** section. Repeat sequence until all timer settings are completed.

If, however, a timer is not used, set ON and OFF times to 00:00. Timer setting can be randomly selected.

5. Manual/ Forced Defrosting:

Although this heat pump features an automatic defrosting function, a manual defrosting function enables the user to manually defrost the heat pump when unusual frosting appears. Make sure the key-pad is unlocked. Ensure that heat pump unit is in running mode, displaying the heat symbol.

Press the “” key for more than 8 seconds until an audible tone is heard, and release key. The heat pump will be in defrosting mode and the “defrost” symbol will be on display.

General Operating Guide

Initial Start-Up Precautions

First boot-strap and running state checks.

1. To ensure the power to the unit is at the correct voltage.
2. Unit electrical connections: Check if power supply wire connections are okay; if earth wire is properly connected; check if water pump and other chain devices are properly connected.
3. Water pipe and pipes: ensure all pipes have been flushed and are free of debris.
4. Check water system: make sure the water flow is adequate and there is no air or leakages.
5. First boot-strap or starting up again after being shut down for a long time, stop, ensure power is on ahead and heating at least 12 hours for crankcase (local loop temperature is zero). Water pump starts up first, fan starts up, and then compressor starts up and begins regular operation.
6. Running checks: check the following items:
 - a. Input and output water temperature.
 - b. Water flow rate.
 - c. Running electric current of compressor and fan.
 - d. High and low-pressure value when heating is running.

 **CAUTION** – Refrain from using this heat pump if any technical components have been in contact with water. Immediately call a qualified service technician to inspect the heat pump.

 **CAUTION** – Keep all objects clear from above the heat pump. Blocking air flow could damage the unit and may void the warranty.

Users Guide

1. Rights and Responsibility

1.1 To ensure you have the service guarantee period, only qualified heating engineers can install and repair the unit. If you infract this request and cause any loss and damage, our company will not be held responsible. Please refer to your warranty card for further information.

2. User Guide

2.1 All safety protection devices are set in unit before leaving the factory, don't adjust it by yourself.

2.2 Units have been charged with refrigerant and lubricating oil, if needed owing to a leak; please refer to the charging quantity on nameplate.

2.3 The external water pump must be connected to the output from the unit.

2.4 Use antifreeze / glycol when the environment temperature is less than zero in winter.

2.5 Safety Precautions

- a. Unit must be installed by a competent person, plumber or heating engineer.
- b. Please check that power supply corresponds with unit size.
- c. The main power switch of unit should have earth leakage protector; the power cable must meet the unit power requirements.
- d. Unit must have a ground wire; don't use the unit if there is no ground wire.
- e. Don't use the unit if the fan fence has been removed.
- f. To avoid electric shock or fire, don't store or use, oil paint, petrol, combustible gas or liquid around the unit; don't throw water or other liquid on to the unit and don't touch the unit with wet hands.
- g. Don't adjust the switch, valve, controller or internal data without permission of customer support team.
- h. If a safety protection device is activated at start up, please contact the customer support team.

Product Protection

1. **Compressor Time Delay Protection:** To ensure the compressor is protected, a time delay of 3 minutes is needed to restart the compressor following it becoming satisfied.

2. **Compressor High Discharge Temperature Production (error code: Er28):** If a high compressor discharge temperature ($\geq 115\text{C}$ (239F)) is detected for 30 seconds, the heating function will be disabled, and the error code will be displayed. The heat pump will resume operating automatically after 3 minutes.

4. **Compressor High Pressure Protection (error code: Er15):** If a high pressure is detected on the compressor, the heating function will be suspended, the error code will be displayed, and the alarm will sound. The heat pump unit will resume operation 3 minutes after the high pressure switch was rest. If the same error code appears for 3 consecutive times within an hour the heating function will be permanently disabled and the alarm will sound. Please consult an authorised service technician. This error normally relates to an inadequate water flow rate causing the heat pump to overheat, check that the system pipework has been designed to allow the water flow rate required on the data badge.

5. **Compressor Low Pressure Protection (error code: Er27):** If a low pressure is detected on the compressor, the heating function will be suspended, the error code will be displayed, and the alarm will sound. The heat pump unit will resume operation 3 minutes after the high pressure switch was rest. If the same error code appears for 3 consecutive times within an hour, the heating function will be permanently disabled, the error code will be displayed and the alarm will sound. Please consult an authorised service technician.

NOTE: Low pressure will not be detected under 2 circumstances, during the defrosting period and/or during the first 5 minutes after the compressor has started.

7. Frost Protection:

- During constant temp standby or power off, if ambient temp $\leq 2^{\circ}\text{C}$, the unit goes into anti-freeze protection mode 1, circulating water pump every 40mins for 5min. When ambient temperature increases the unit will exit anti-freeze protection mode.
- During constant temp standby or power off, if ambient temp $\leq 2^{\circ}\text{C}$, and water tank probe is $\leq 4^{\circ}\text{C}$, the unit goes into anti-freeze protection mode 2, automatically heating until water tank temp probe reaches $\geq 15^{\circ}\text{C}$ or ambient temp $\geq 8^{\circ}\text{C}$ then the unit will exit anti-freeze protection mode 2.
- During antifreeze mode the outlet water temp $\leq 2^{\circ}\text{C}$, warns water pump fault Er25, until the outlet water temp $\geq 4^{\circ}\text{C}$.
- If there is a water tank temperature probe fault and then ambient temp decides to go into anti-freeze mode, it will only trigger mode 1.
- If there is an ambient temperature probe fault, then the unit automatically goes into mode 1 anti-freeze protection.
- If ambient temperature probe and outlet temperature probe both give a fault, then then the unit will go into mode 1 anti-freeze protection and water pump will function.

9. Compressor over Current Protection (Er37): - Not Currently Used

10. Controller Communication Faults (Er08):

- The first time the unit powers on, if within 20 seconds the PCB doesn't receive communication from remote controller, it will operate to "the last input parameter";
- If when the unit is running, and remote controller doesn't receive communication from PCB for a constant 10 seconds it is judged as a communication fault, the unit will display fault code Er08. During this time the unit works as per original settings and after communication fault is corrected the fault will disappear.

Section 4

General maintenance

Controller Error Codes

The following Common Error Codes for the heat pump units displayed on the controller:

CODE	NAME	CODE	NAME
Er01	PCB / Wire Controller Fault	Er19	Return air probe fault
Er02	Water Tank Probe Fault	Er20	Throttled temperature probe fault
Er03	Supply Water Probe Fault	Er21	Heating return water higher protection
Er04	Return Water Probe Fault	Er22	Cooling water temperature too low
Er05	Evaporator temperature probe fault	Er23	Inlet / Outlet difference too high
Er06	Ambient temperature probe fault	Er24	Self check fault
Er07	Compressor discharge probe fault	Er25	Antifreeze protection
Er08	Contoller and PCB communication fault	Er26	PCB & Inverter PCB communication fault
Er09	PCB & inverter board communication fault	Er27	Low Pressure Fault
Er10	Self Check	Er28	High Pressure Fault
Er11	Over current protection	Er29	Cooling temperature too high fault
Er12	Modular board fault	Er30	Ambient temperature low propection
Er13	Water pressure fault	Er33	Compressor Starts Loose
Er14	Water flow protection	Er34	Compressor speed abnormal
Er15	High pressure protection		

NOTE:

If a fault occurs during normal heat pump operation, a common error code will be displayed on the controller display panel. Follow the instructions in Section 3, Controller Set-Up, “System status display values (2)” to “inquire” (check) the specific error codes for the corresponding heat pump systems.

Inspection and Service

Cool Energy air source heat pumps are designed and built to provide long life and performance, when installed and operated properly under normal conditions. Periodic inspections are important to keep your heat pump running safely and efficiently.

Owner Inspection

Cool Energy recommends that inspections on heat pumps are done frequently, especially after abnormal weather conditions. The following basic guidelines are suggested for your inspection:

1. Make sure the front of the unit is accessible for service.
2. Keep the top and surrounding areas of the heat pump clear of all debris.
3. Keep all plants and shrubs trimmed and away from the heat pump especially the area around the fan.
4. Keep lawn sprinklers from spraying on the heat pump to prevent corrosion and damage.
5. Ensure that the earth wire is always properly connected.
6. A water filter must be installed and maintained.
7. All the safety protection devices have been set up; please refrain from changing these settings. If any changes are needed, please contact our support team.
8. If the heat pump is installed under roof without a gutter, ensure that all measures are taken to prevent excessive water from entering the unit.
10. Do not use this heat pump if any electrical part has been in contact with water. Contact an authorized service technician.

Troubleshooting

Use the following troubleshooting information to resolve issues with your heat pump.



WARNING — RISK OF ELECTRICAL SHOCK OR ELECTROCUTION.



Ensure that all high voltage circuits are disconnected before commencing heat pump installation maintenance. Contact with these circuits could result in death or serious injury to users, installers or others.

- Keep your hands and hair clear of the fan blades to avoid injury.
- **DO NOT** attempt to adjust or service the unit without consulting your authorized installer/agent.
- **PLEASE** read the complete Installation and/or User's Guide before attempting to operate service or adjust the heater.

AIR TO WATER HEAT PUMP COMMISSIONING CHECKLIST

This Commissioning Checklist is to be completed in full by the competent person who commissioned the heat pump and associated equipment as a means of demonstrating compliance with the appropriate Building Regulations and then handed to the customer to keep for future reference.

Failure to install and commission this equipment to the manufacturer's instructions may invalidate the warranty but does not affect statutory rights.

Customer name:	Telephone number:
Address:	
Heat Pump Make and Model	
Heat Pump Serial Number	
Commissioned by (PRINT NAME):	Certified Operative Reg. No. [1]
Company name:	Telephone number:
Company address:	
Commissioning date:	
Building Regulations Notification Number (if applicable) [2]	

CONTROLS - SYSTEM AND HEAT PUMP (tick the appropriate boxes)			
Time and temperature control to heating	Room thermostat and programmer/timer		Programmable Roomstat
	Load/weather compensation		Optimum start control
Time and temperature control to hot water	Cylinder thermostat and programmer/timer		Combined with Heat pump main controls
Heating zone valves (including underfloor loops)	Fitted		Not required
Hot water zone valves	Fitted		Not required
Thermostatic radiator valves	Fitted		Not required
Heat Pump Safety Interlock [3]	Built In		Provided
Outdoor Sensor	Fitted		Not required
Automatic bypass to system	Fitted		Not required
Buffer Vessel Fitted	Yes	No	If YES Volume: Litres

ALL SYSTEMS	
The heating system has been filled and pressure tested	Yes
Expansion vessel for heating is sized, fitted & charged in accordance with manufacturer's instructions	Yes
The heat pump is fitted on a solid/stable surface capable of taking its weight	Yes
The system has been flushed and cleaned in accordance with BS7593 and heat pump manufacturer's instructions	Yes
What system cleaner was used?	
What inhibitor was used?	Quantity litres
Is the system adequately frost protected?	Yes

OUTDOOR UNIT	
Are all external pipeworks insulated?	Yes
Is the fan free from obstacles and operational?	Yes
Has suitable consideration been made for waste water discharge?	Yes

CENTRAL HEATING MODE			
Heating Flow Temperature	°C	Heating Return Temperature	°C

DOMESTIC HOT WATER MODE Measure and Record:			
Is the heat pump connected to a hot water cylinder?	Unvented	Vented	Thermal Store
Hot water has been checked at all outlets	Yes	Have Thermostatic Blending Valves been fitted?	Yes
			Not required

ADDITIONAL SYSTEM INFORMATION						
Additional heat sources connected:	Gas Boiler	Oil Boiler	Electric Heater	Solar Thermal	Other:	

ALL INSTALLATIONS	
The heating, hot water and ventilation systems complies with the appropriate Building Regulations	Yes
All electrical work complies with the appropriate Regulations	Yes
The heat pump and associated products have been installed and commissioned in accordance with the manufacturer's instructions	Yes
The operation of the heat pump and system controls have been demonstrated to the customer	Yes
The manufacturer's literature, including Benchmark Checklist and Service Record, has been explained and left with the customer	Yes

Commissioning Engineer's Signature
Customer's Signature
(To confirm satisfactory demonstration and receipt of manufacturer's literature)

Notes: [1] Installers should be members of an appropriate Competent Persons Scheme. [2] All installations in England and Wales must be notified to Local Area Building Control (LABC) either directly or through a Competent Persons Scheme. A Building Regulations Compliance Certificate will then be issued to the customer. [3] May be required for systems covered by G3 Regulations

© Heating and Hot Water Industry Council (HHIC)



SERVICE RECORD

It is recommended that your heating system is serviced regularly and that the appropriate Service Interval Record is completed.

Service Provider

Before completing the appropriate Service Record below, please ensure you have carried out the service as described in the manufacturer's instructions. Always use the manufacturer's specified spare part when replacing controls.

SERVICE 01		Date:	SERVICE 02		Date:
Engineer name:		Engineer name:		Engineer name:	
Company name:		Company name:		Company name:	
Telephone No:		Telephone No:		Telephone No:	
Operative ID No:		Operative ID No:		Operative ID No:	
Comments:		Comments:		Comments:	
Signature		Signature		Signature	
SERVICE 03		Date:	SERVICE 04		Date:
Engineer name:		Engineer name:		Engineer name:	
Company name:		Company name:		Company name:	
Telephone No:		Telephone No:		Telephone No:	
Operative ID No:		Operative ID No:		Operative ID No:	
Comments:		Comments:		Comments:	
Signature		Signature		Signature	
SERVICE 05		Date:	SERVICE 06		Date:
Engineer name:		Engineer name:		Engineer name:	
Company name:		Company name:		Company name:	
Telephone No:		Telephone No:		Telephone No:	
Operative ID No:		Operative ID No:		Operative ID No:	
Comments:		Comments:		Comments:	
Signature		Signature		Signature	
SERVICE 07		Date:	SERVICE 08		Date:
Engineer name:		Engineer name:		Engineer name:	
Company name:		Company name:		Company name:	
Telephone No:		Telephone No:		Telephone No:	
Operative ID No:		Operative ID No:		Operative ID No:	
Comments:		Comments:		Comments:	
Signature		Signature		Signature	
SERVICE 09		Date:	SERVICE 10		Date:
Engineer name:		Engineer name:		Engineer name:	
Company name:		Company name:		Company name:	
Telephone No:		Telephone No:		Telephone No:	
Operative ID No:		Operative ID No:		Operative ID No:	
Comments:		Comments:		Comments:	
Signature		Signature		Signature	



Cool Energy Holding Ltd.

163 Cleethorpe Road,
Grimsby,
DN31 3AX.

Email: sales@coolenergyshop.com

www.coolenergyshop.com

