

# STINGER CARBONFIBER BODYKIT

## 장착 설명서

### 전면부

#### 카본파이버 프론트 립 Carbonfiber Front Lip

① 좌우 대칭의 가장 적절한 피팅 위치를 설정한 후, 전용 피스를 이용해 가접합니다.

② 지정된 장착 포인트에 따라 전동공구를 이용해 볼트-너트를 식립합니다.

- ③ After setting the most suitable fitting position for left and right symmetry, use a screw to temporarily fitting.
- ④ After fitting with the vehicle through temporary welding, remove the cover of the double-sided tape and fix it. and finish with power tools.

#### 카본파이버 프론트 어퍼 Carbonfiber Front Upper

① 벨크로 테이프를 이용하여 적절한 피팅 위치를 설정한 후, 스페이서와 볼트-너트를 결합합니다.

Attach the carbon upper part to the right position and weld temporarily with the hook and loop tape. after that, fix the part with power tools.

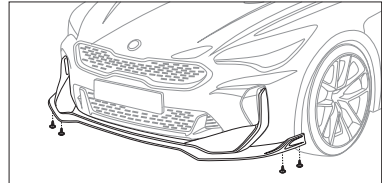
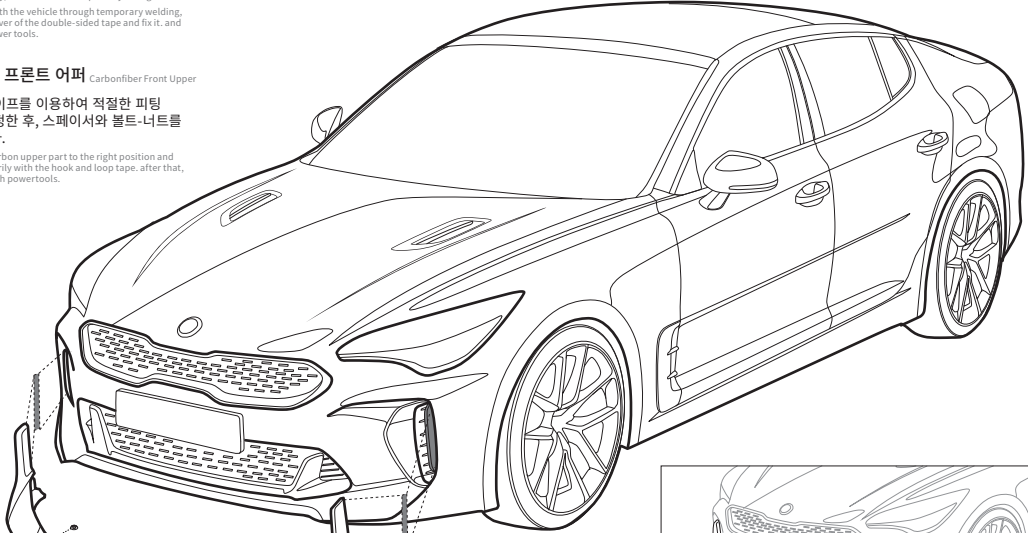
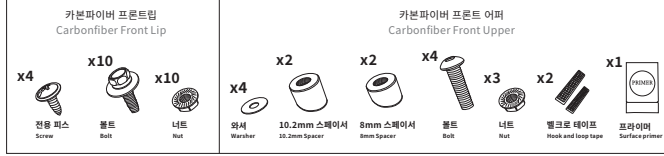

동봉된 피스를 이용하여 미세단차들을 보정합니다.



### 장착 포인트

Installation spot

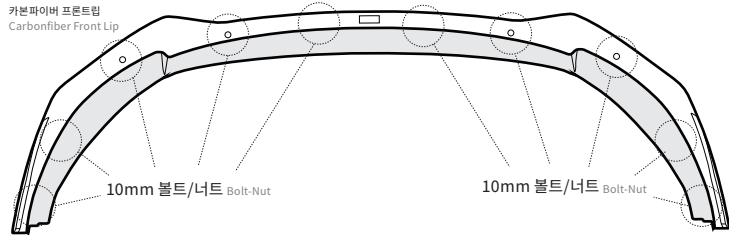

#### 카본파이버 프론트 어퍼 Carbonfiber Front Upper

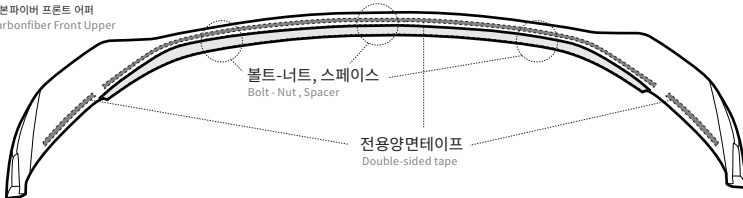

## 측면부 - 사이드 스커트(LH, RH)

- ① 좌우 대칭에 가장 적합한 피팅 위치를 설정한 후, 피스를 이용해 가접합니다.
- ② 지정된 장착 포인트에 따라 전동공구를 이용하여 피스를 식립합니다.

- ① After setting the most suitable fitting position for left and right symmetry, use a screw to temporarily fitting.
- ② After fitting with the vehicle through temporary welding, add more screw to fix the assembly

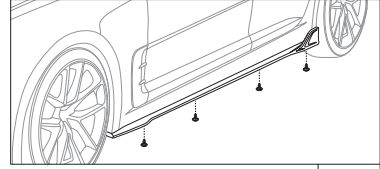
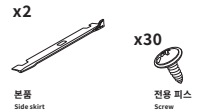

여분의 피스를 이용하여 미세단차들을 보정합니다.

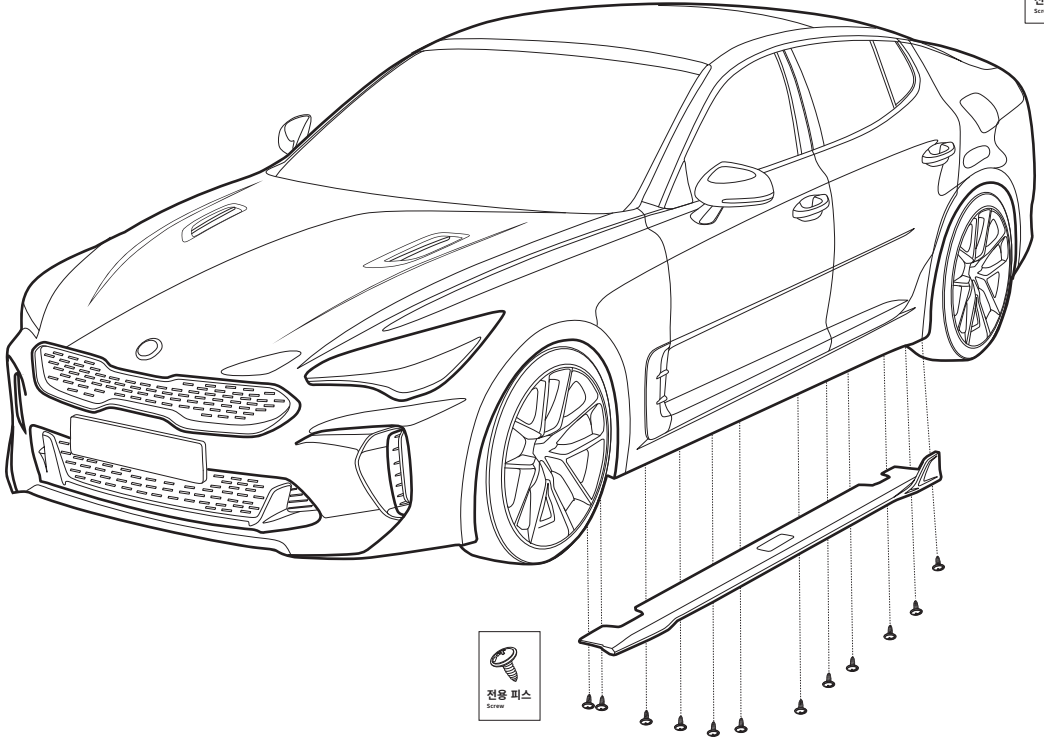

### 장착 포인트 Installation spot

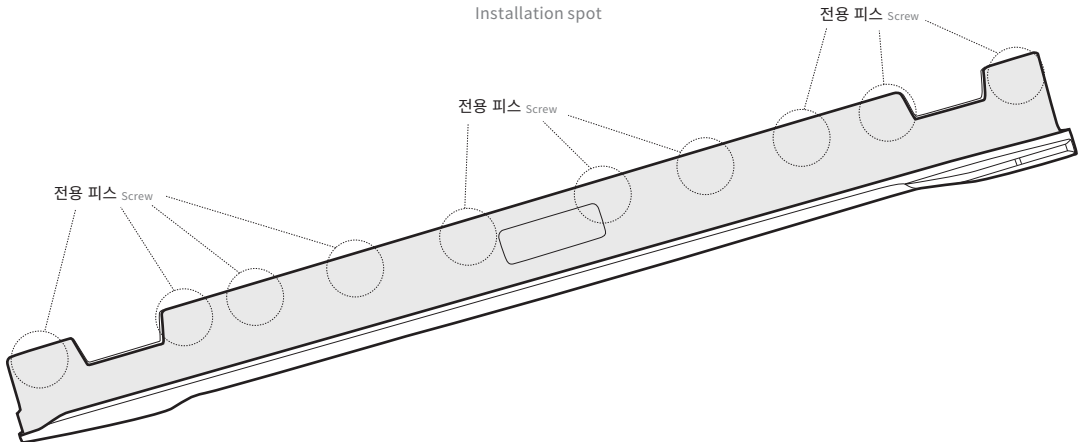

## 후면부 - 리어 디퓨저



- ① 가접을 통한 차량과의 피팅 후, 양면테이프의 커버를 떼어내어 접착시킵니다.
- ② 지정된 장착 포인트에 따라 전용공구를 이용해 볼트-너트를 식립합니다.

- ① After fitting with the vehicle through temporary welding, remove the cover of the double-sided tape and fix it.
- ② Insert the bolt-nut using the power tool according to the specified mounting point.

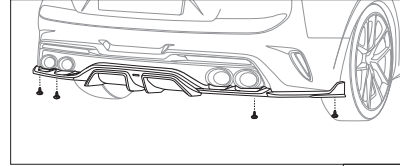

동봉된 피스를 이용하여 미세단차들을 보정합니다.

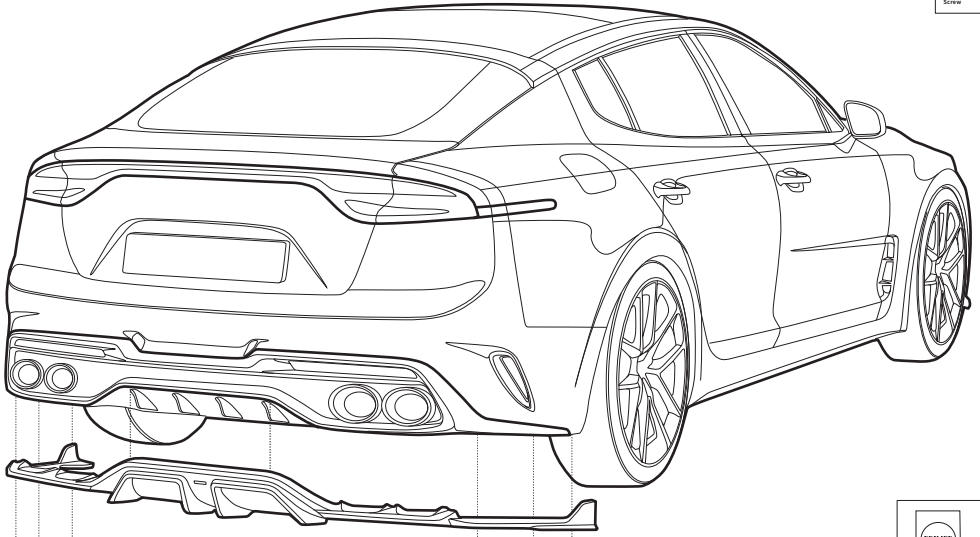

\*양면테이프 부착 전, 동봉된 프라이머를 이용해 표면 작업을 해줍니다.(프라이머 과사용시 도장면 손상 주의)  
 \*Before fixing through the double-sided tape, use the enclosed primer on the car body(Surface primer can scratch car paints)

### 장착 포인트 Installation spot

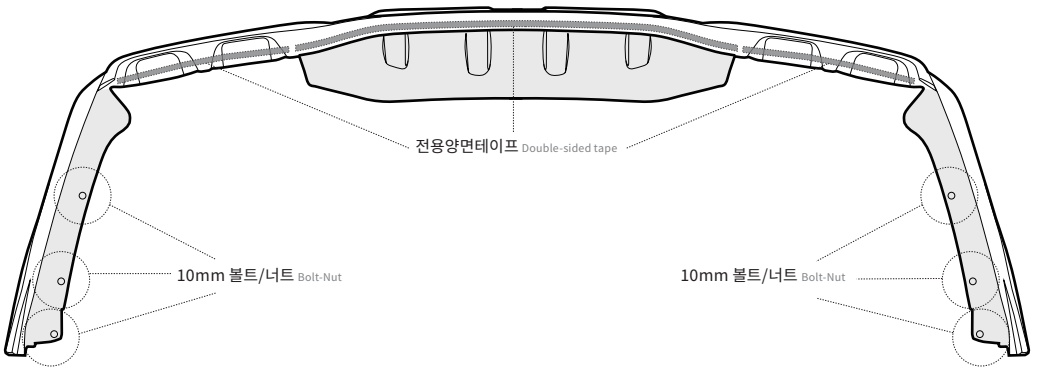

# 후면부 - 카본 에어벤트 커버

x1

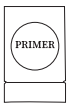

프라이머  
Surface primer

- ① 장착면에 동봉된 프라이머를 도포합니다
- ② 부착면의 양끝을 기준으로 정확한 피팅 후에 양면테이프의 필름을 벗겨내어 고정합니다.

- ① Apply the enclosed primer to the mounting surface
- ② After fitting with the vehicle through temporary welding, remove the cover of the double-sided tape and fix it.

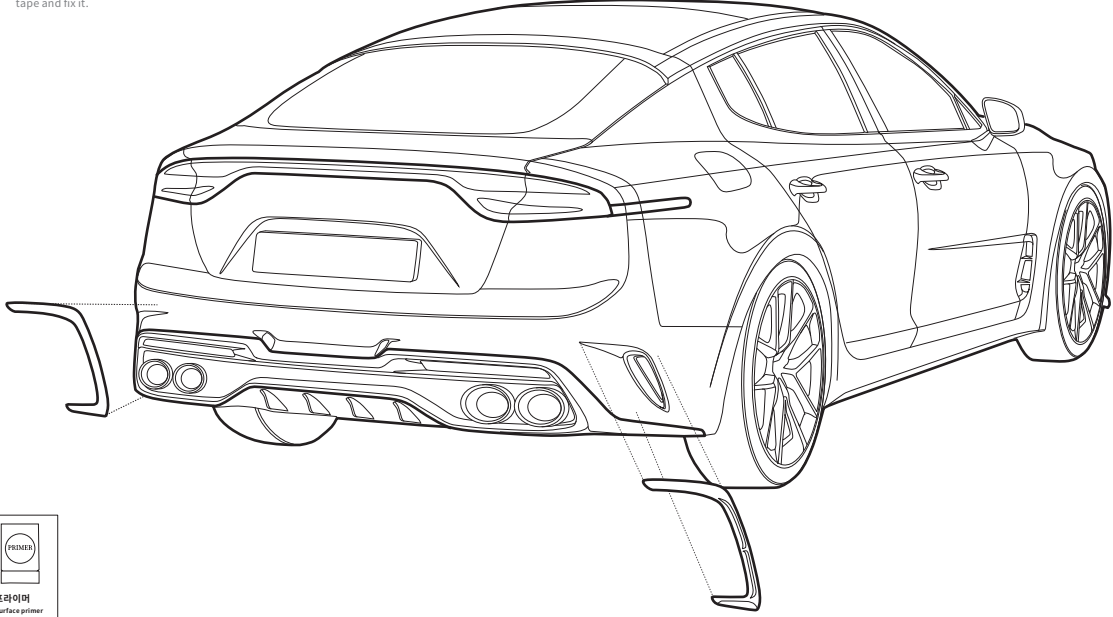

\*프라이머  
Surface primer

\*양면테이프 부착 전, 동봉된 프라이머를 이용해 표면 작업을 해줍니다. (프라이머 과사용시 도장면 손상 주의)  
\*Before fixing through the double-sided tape, use the enclosed primer on the car body. (Surface primer can scratch car paints)

## 장착 포인트 Installation spot

전용양면테이프 Double-sided tape

