

# SERV-OIL® INJECTION LUBRICATORS

## WHAT IS SERV-OIL?

**SERV-OIL** is the most advanced system for the precision lubrication of pneumatic equipment. It has been used for over thirty years to provide lubrication to all kinds of pneumatic equipment and various fixtures, bearings, slides, and ways. It overcomes the control problems that can be encountered with conventional mist lubricators. It also ensures proper lubrication of pneumatic components in complex circuits, and accurately delivers lubricant to points at a long distance from the lubricator.

Positive-displacement oil injectors, called Servo-Meters, are the heart of **SERV-OIL** equipment. They put pre-determined, precise amounts of oil right at the points where lubrication is needed. By comparison, mist lubricators lack the precision and control of a **SERV-OIL** system. Extensive tests have shown that when a conventional mist lubricator is installed upstream of a control valve, much of the oil dispensed by the lubricator is exhausted to atmosphere through the exhaust port of the control valve. This is inefficient, and also contributes significantly to pollution of plant air.

With **SERV-OIL** equipment the amount of oil used is greatly reduced and lubrication is more effective because of the accuracy with which the oil is delivered. Briefly: **SERV-OIL** lubricates the component, not the area!



### Servo-Meter: Key Element in SERV-OIL Equipment

- ◆ Actuated by air pulse (60 psig minimum).
- ◆ Choice of 3 output ratings: 1/2, 1 or 2 drops.
- ◆ Output adjustable in small increments.
- ◆ Positive displacement metering ensures precise oil delivery with each actuation.
- ◆ Modular assembly allows up to 10 Servo-Meters to be built into a single assembly.
- ◆ Servo-Meters easily added or removed from multiple-unit assemblies.

## DO YOU NEED SERV-OIL?

If any **ONE** of the following statements describes a situation in your plant, you can reap long-term dividends by the use of **SERV-OIL** equipment.

- ◆ We repair air tools because the vanes are worn and the cylinders and rotors are scored due to insufficient lubrication.
- ◆ The appearance of fog or mist lubrication is a hazard in our plant.
- ◆ Over-lubrication costs us money because of the stringent requirements for disposing of used lubricants.
- ◆ Air cylinders in our plant become sluggish because of varnish or other contaminants.
- ◆ Torque control in our air tools is variable and doesn't meet our requirements.
- ◆ We set pressure regulators higher than the work requires just to overcome stiction in valves, cylinders, or other air components.
- ◆ If one pump fails in our lubrication system, the performance of other pumps is adversely affected.
- ◆ Sometimes lubricators are turned off, or the lubrication adjustments have been tampered with by unauthorized personnel. Such tampering removes lubrication control from the proper hands.
- ◆ We use flood coolants to lubricate taps and drills. The cost and environmental impact of this have not been considered.
- ◆ It would be to our advantage to know exactly what lubrication is being provided, and when to fill our lubricator reservoirs.

# SERVO-METER: Key SERV-OIL Module

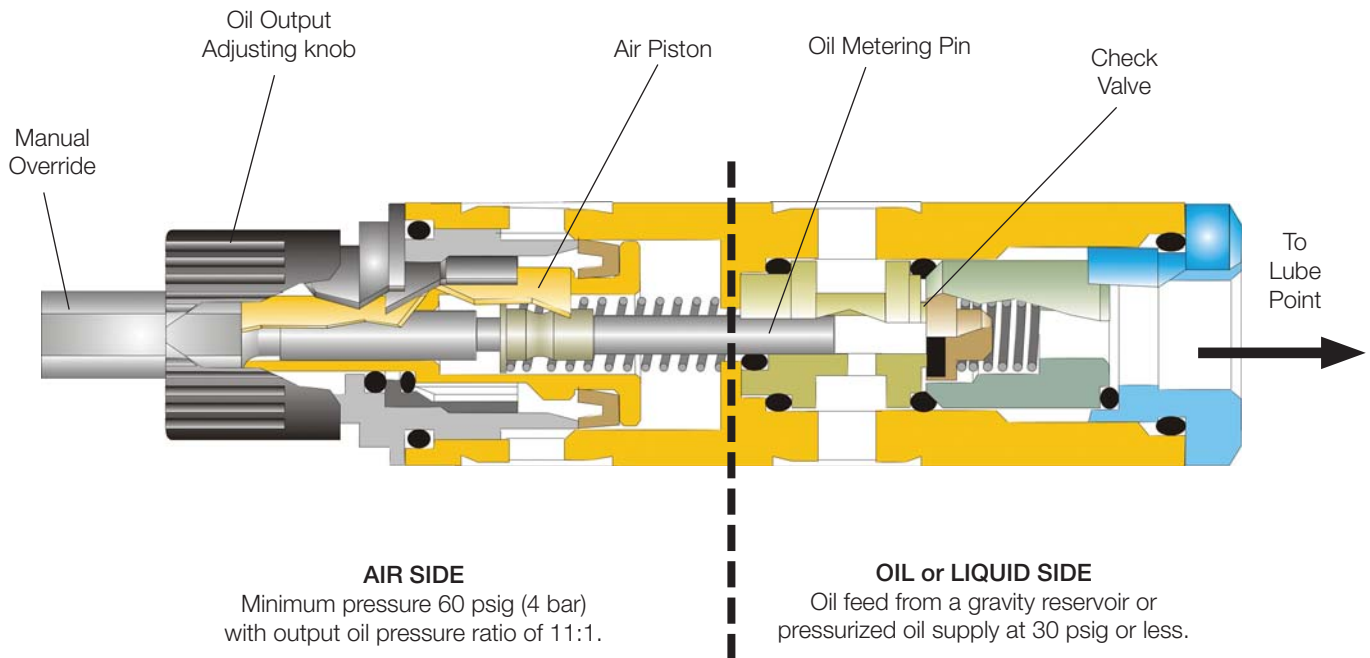

**Cutaway Drawing of SERVO-METER**

Servo-Meters are the key modules in all the **SERV-OIL** equipment. They are precision, positive-displacement liquid injectors which are actuated by an air pressure signal of at least 60 psig (4 bar). 1/8-Inch oil-filled nylon line carries the injected oil from each Servo-Meter to a point of lubrication. Servo-Meters in single-point lubricators have a flow-actuated ball in the sight indicator at one end of the Servo-Meter to give visual verification of oil delivery. Ball check valves at the ends of the nylon lines ensure that the lines and the oil sides of the Servo-Meters remain full of oil and free of air.

Servo-Meters are available in three capacities: maximum flows of 1/2 drop, 1 drop, and 2 drops. A Servo-Meter is adjustable so that the maximum amount can be reduced in increments of 1/50th of its rated capacity as shown in the following chart: (Note: 1 drop = 1/30 cc.)

Maximum Output	Reducing Increments	Minimum Output
1/2 drop	1/100 drop	1/20 drop
1 drop	1/50 drop	1/10 drop
2 drops	1/25 drop	1/5 drop

With the aid of pulse counters and the controllers described on the next page, lubrication can be reduced even further by selecting the frequency of oil injection.

**SERV-OIL** equipment described on the following pages may be designed for either single Servo-Meter service or multiple (up to twenty) Servo-Meter service. Servo-Meters are made for modular assembly so that the equipment using multiple Servo-Meters can have them added or removed very simply.

**SERV-OIL** units employing multiple Servo-Meters use the same oil supply and the same air signals. An accessory block plate can be used in a stack of Servo-Meters to allow the use of two different air signals. All the Servo-Meters will continue to use the same oil supply. See **SERV-OIL** Accessories on page 223 for further details.

Although Servo-Meters are most commonly used to inject oil, they can also be used with other liquids. Before using them with other liquids, consult Master Pneumatic for advice on such applications.

# SERVO-METER Controllers

Servo-Meters can be set to dispense widely different amounts of oil on each actuation. In addition, every SERV-OIL unit employs a controller to regulate the frequency with which the Servo-Meter(s) in the unit are actuated. This control of both the amount and frequency of lubrication makes for the greatest efficiency and economy of use of lubricants.

Controllers range from simple pulse counters to units that create the pulses that actuate the Servo-Meters.

## INTEGRATED CONTROLLERS



**Pneumatic Pulse  
Controller**

**Pneumatic Pulse Counter.** A multiple-point lubricator with pulse counter is shown at the left. The counter receives air pulses (usually from the output of an operating valve) and determines which of the pulses it will pass on to the Servo-Meter and so become an actuating signal. A ratcheting mechanism in the counter can be set to make an actuating signal of every pulse, every 5th pulse, or every 10th pulse.

Pulse counters can be paired in tandem so that lubrication frequency can be reduced to as little as every 100th pulse.

**Frequency Generator.** This all-pneumatic device requires a steady supply of input air, and is used most often where on-off air-input pulses are not available. From the steady air input the generator produces output pulses to actuate Servo-Meters. This type of controller is shown at the right as an integrated part of an Automation Pac assembly.

A frequency generator's output is most accurate when producing pulses with a period of 1 to 30 seconds. The generator can be combined with a pulse counter to produce a final pulse output with periods from 1 second to 5 minutes. The actuating pulse frequency in seconds of



the pulse counter and frequency generator combination is equal to the pulse counter setting (1, 5, or 10) multiplied by the frequency generator setting (1 to 30).

## STAND-ALONE CONTROLLERS



**Series PC100 Controller.** This is a stand-alone assembly of two pulse counters, and a coalescing filter to provide clean input air. A pulsed air input (usually from the output of an operating valve) is required. This controller can be used for a number of **SERV-OIL** units instead of having a counter in each of the individual units. This provides greater economy and superior control.

**Series PC110 Controller.** This is a stand-alone assembly that combines a pulse counter, a frequency generator, and a coalescing filter to provide clean input air. A steady flow of input air is required. The steady flow is converted into controlled pulses to actuate Servo-Meters.

As explained above, the settings of the pulse counter and the frequency generator can produce actuating pulses in periods as long as five minutes.

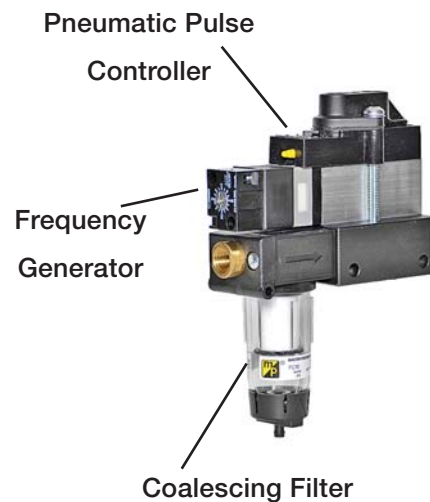

# The SERV-OIL Family of Products

## AUTOMATION PAC –

This is a self-contained assembly consisting of an oil reservoir, up to 20 Servo-Meters, and frequency controller. It is supplied ready for installation in a pneumatic circuit, with only ball checks, fittings, and tubing being required accessories. The Automation Pac will provide precision lubrication for valves, cylinders, fixtures, and machine tools using pneumatic components.



## SINGLE-POINT INJECTION LUBRICATOR for AIR TOOLS –

This unit is specifically designed to lubricate air tools. It cannot be used for other lubrication. For other single-point lubrication see the Downstream Lubricator below.



## SINGLE-POINT DOWNSTREAM INJECTION LUBRICATOR –

The downstream lubricator is installed in an air line going to cylinders, air motors, or other pneumatic equipment except air tools. See above for air tools. A small nylon line carries oil from the lubricator to the desired point of lubrication. Most commonly the nylon line runs inside the air line.



## MULTIPLE POINT INJECTION LUBRICATORS –

Up to ten Servo-Meters can be assembled to provide precision lubrication for up to ten lubrication points. All Servo-Meters use the same oil and air sources.



## LIQUID-ONLY EJECTOR –

A Servo-Meter is terminated with a nozzle through which a precise amount of liquid can be ejected up to ten inches. Assemblies of up to 10 Servo-Meters can be used.

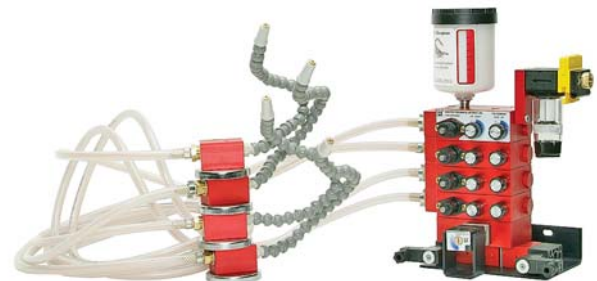

**COMPLETE LUBRICATION SYSTEMS –** All-in-one lubrication or coolant systems are engineered for many specialized requirements. See the descriptions of the **SCORPION** systems at the end of this section.

# PNEUMATIC TOOL LUBRICATION

## The Best Way to Do It!

### CONVENTIONAL MIST LUBRICATION

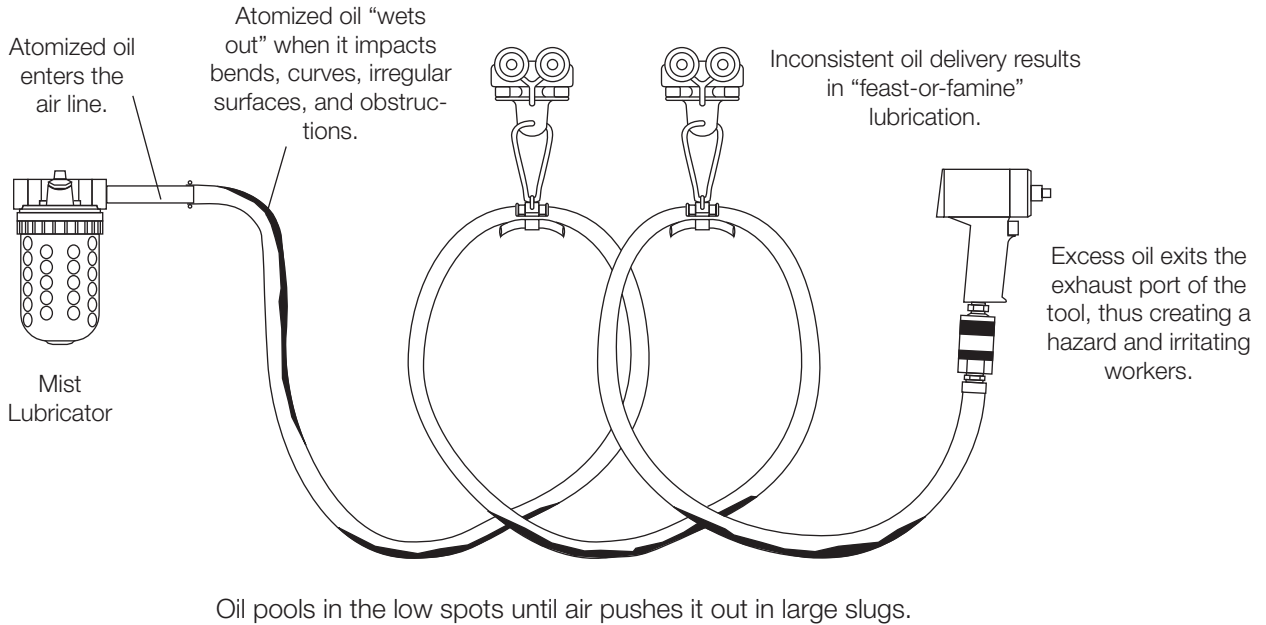

### INJECTION LUBRICATION

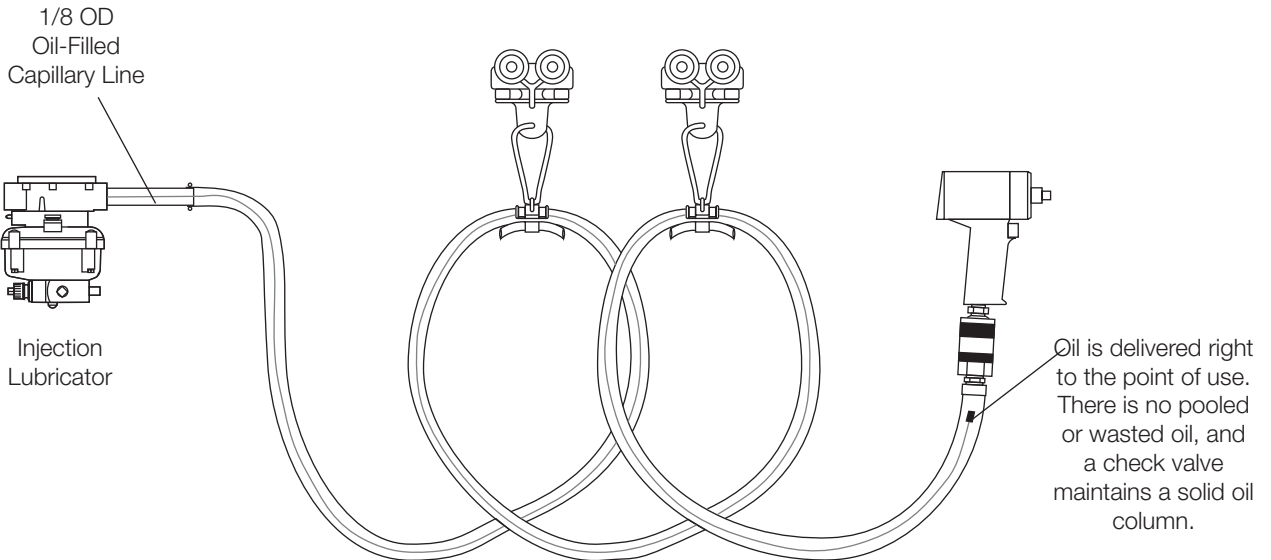

Consistent, Precision Lubrication Results in Consistent Torque and Tool Performance.

# The Importance of SERV-OIL to Air Tools

Air tools are very economical devices for tightening threaded fasteners. They are usually smaller and lighter than similar electric or hydraulic tools, and have the advantage of being able to stall without suffering motor damage. However, understanding the mechanics of an air tool will make it clear why it requires consistent, controlled lubrication.

## CONSTRUCTION

The most common motor design used in air tools is the rotary vane type. A typical cross section of such a motor is shown below.

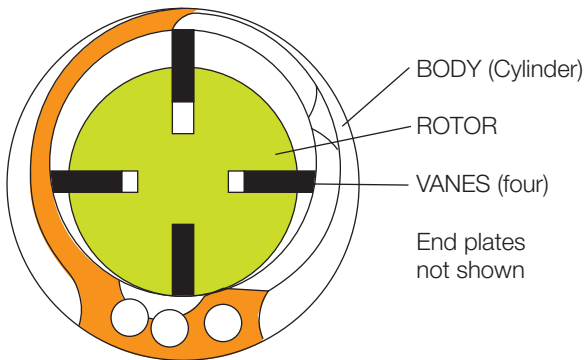

The motor body is usually of cast metal. Its inside diameter and is machined and polished to a high finish. The diameter and length of the body will determine the size and capacity of the motor. The rotor's diameter is about 85% of the inside diameter of the body, and has radial slots to accommodate the four vanes. The vanes are as long as the rotor, and are linen-based, phenolic resin strips. The two end plates are made of a soft metal. They support the rotor shaft and serve as dynamic seals.

Note that the cylinder inside diameter and the rotor diameter have different center points. The difference is such that the two surfaces will be tangent where the bottom of the rotor touches the cylinder. Note also that the vanes slide in the rotor slots so that they maintain contact with the cylinder. This contact can be maintained by springs beneath each vane, or, more commonly, by air pressure.

## WORK CYCLE

Referring to the diagram below we can follow a work cycle of the air motor.

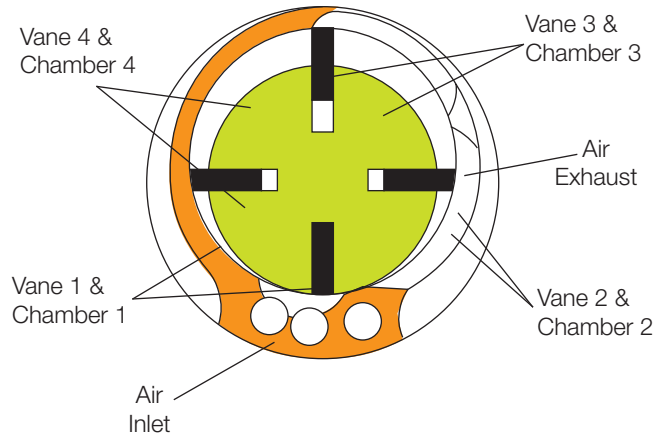

Vaness divide the space between the rotor and cylinder into four chambers. Chamber 1 includes the inlet port. When pressurized air enters chamber 1 it causes the rotor to turn clockwise. When vane 2 clears the inlet port, chamber 2 is pressurized and the rotation continues. As each chamber reaches the exhaust port its pressure is exhausted. A positive pressure differential between the chambers on the left and those on the right must be maintained in order for the rotor to rotate.

Maintaining a good seal between chambers is the function of the vanes. The most important seal points are where the vanes contact the cylinder, with the seal of the bottom vane being the most critical. It is here that the pressure differential between the inlet and exhaust sides of the motor must be maintained. If the seal points leak, the pressure differential drops, and the motor loses torque.

The wear of the seals is magnified by hit-or-miss lubrication. Without oil the vanes take a beating, and eventually crack and chip. The chips score the cylinder and rotor, and may even wedge themselves between vanes and cylinder. The air motor is approaching uselessness!

The **SERV-OIL** Single Point Lubricator is specifically designed to inject a predetermined amount of oil at the inlet of the air tool every time it cycles. Maximum performance. Extended life. Reduced maintenance. Less downtime. Improved torque control. These are all the result of **PRECISE, CONSISTENT LUBRICATION.**

## TYPICAL MPL APPLICATION With 2-Drop Servo-Meters and Integral Oil Reservoir

Diagram A at the right shows a simple circuit using three 2-drop Servo-Meters and an integral oil reservoir. The actuating signal for the Servo-Meters is taken from the downstream side of the operating valve. Each actuation of the valve causes the Servo-Meters to inject oil at three different specific lubrication points. The Servo-Meters can be set to inject as little as 1/5th drop or as much as 2 drops per cycle. No controller is required in this application.

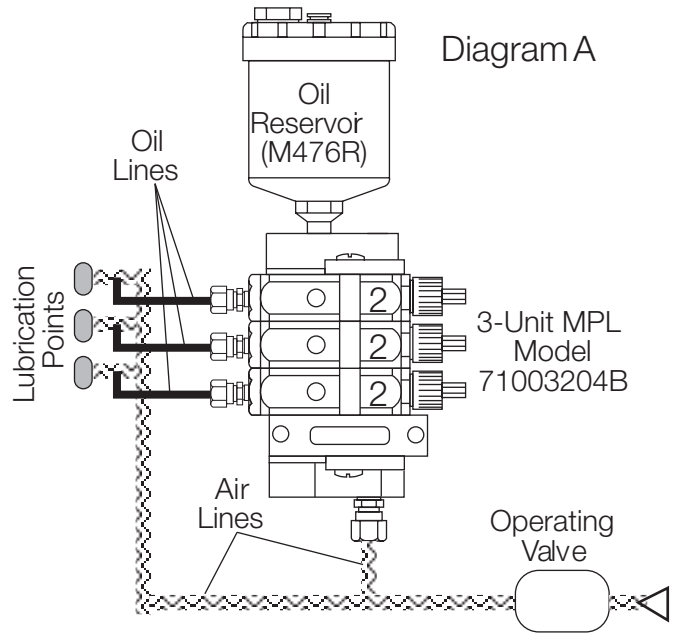

## TYPICAL MPL APPLICATION

### With 1-Drop Servo-Meters, a Pulse Counter, and Remote Oil Reservoir

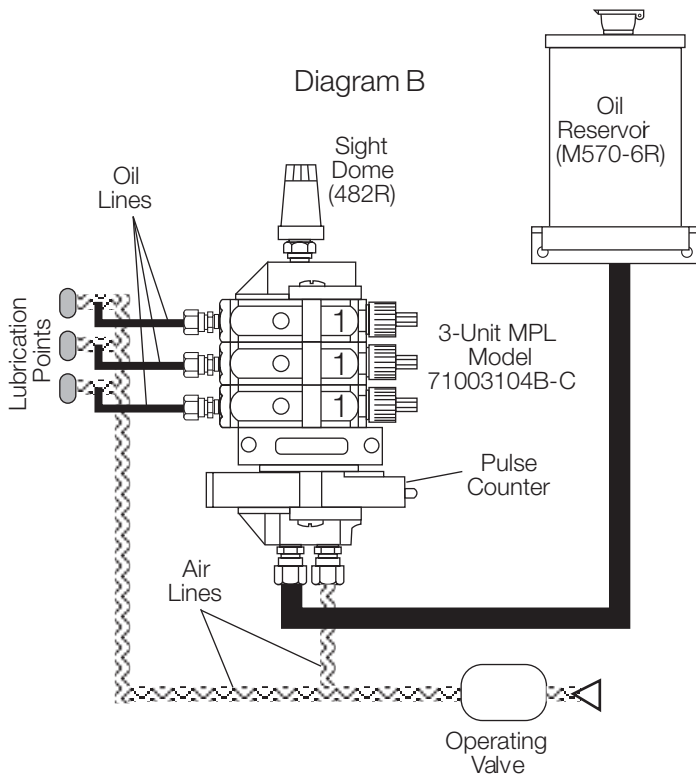

Diagram B at the left shows a circuit using three one-drop Servo-Meters, a pulse counter, and a remote one-quart oil reservoir. The actuating signal for the Servo-Meters is taken from the downstream side of the operating valve. The Servo-Meters can deliver from 1/10th drop to one drop of oil to each of the three different lubrication points. The pulse counter can be set to reduce lubrication by allowing only every 5th or 10th air pulse from the operating valve to actuate the Servo-Meters. For even greater reduction of the lubricating frequency, two pulse counters acting in tandem can be used.

Note the use of a sight dome to vent air from the system.

**An additional Typical Application using a stand-alone frequency generator is shown on the following page.**

## TYPICAL MPL APPLICATION

### With 1/2-Drop Servo-Meters, a Frequency Controller, and Remote Oil Reservoir

In diagram C at the right the **MPL** has 1/2-drop Servo-Meters which can supply from 1/20th drop to 1/2 drop of oil at each actuation. A 10-gallon metal oil reservoir is used. This reservoir could actually supply a number of similar **MPL** lubricating systems. Oil is introduced at the bottom of the assembly, and a sight dome is used to prevent airlock of the Servo-Meters.

A stand-alone frequency controller determines how often the Servo-Meters will inject oil. This can be as often as every second or as infrequent as every five minutes. Air for the controller is from a constant, no-pulse source which the controller will use to create the actuating pulses for the Servo-Meters. The air signal can be introduced at either the top or the bottom of the assembly.

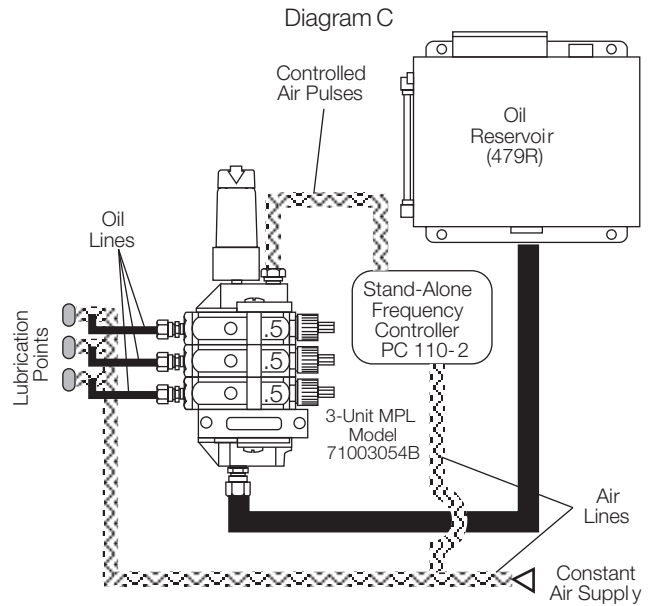

## ASSEMBLY OF MPL SYSTEMS

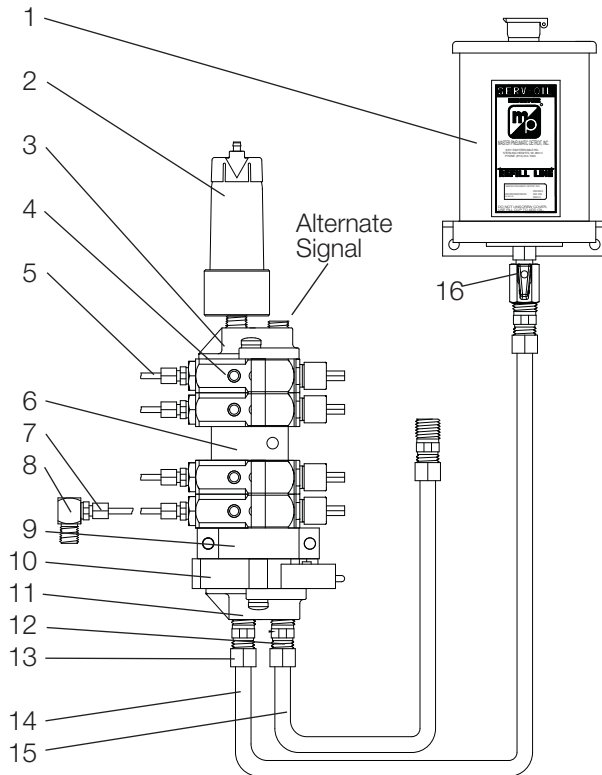

1. Oil reservoir
2. Sight dome for venting air manually and to give visual confirmation of oil in Servo-Meters. Part **482R**.
3. Mounting clamp.
4. Servo-Meter.
5. Prefilled 1/8" nylon oil delivery line. Part **A00942M**.
6. Block plate. Block plate with seals and hardware is kit number **K474-07T**. See page 363.
7. Tube connector. Part **00142W**
8. Ball check valve. One required for inlet to tee before air valves. See page 363 for types and sizes.
9. Mounting plate.
10. Pneumatic pulse counter.
11. Mounting clamp.
12. Tube connector. Part **00184W**.
13. Tube connector. Part **001124W**.
14. Oil supply line; 3/8" nylon tubing. Part **009126-M**. Larger size can be used.
15. Air signal line; 1/4" nylon tubing. Must be from on-off source, usually downstream of operating valve. Part **00984M**. Note: When using a pulse counter, the air signal must first go to the counter, then to the Servo-Meters.
16. 476-40 Ball valve

### MPL ASSEMBLY KITS

Servo-Meter Kit (see footnotes)	70001##4B-@
Mounting/Assembly Kit	KA474-10

## – Specify rating:  
 1/2 drop .....05  
 1 drop..... 10  
 2 drops.....20

@ – Specify options.  
 See OPTIONS under  
 Ordering Information on  
 following pages.



**MPL Mounting Kit**



# SERVO-METERS

## Add-on injectors / replacement kits



Model: 70001104B (Bolts and washers not shown)



Model: 70001104A (Bolts and washers not shown)



Model: 70G01104A (Bolts and washers not shown)

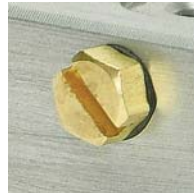

456-138



456-139



456-140

Fittings above are shown attached to housings that have the M5 x 0.8-6h tapped hole on side on unit.



Model: 70E01104B (Bolts and washers not shown)



Standard end cap



Solid end cap



Micro Dial

### SERVO-METER KITS FOR SERV-OIL MULTIPLE-POINT INJECTION LUBRICATORS.

Series 710 and 720

**70 0 01 10 4 B - A W**

#### EXTRA PORTING and MICRO DIAL OPTIONS

- Standard Servo-Meter no options ..... 0
- M5 x 0.8H tapped air hole on breather end of ..... D housing **456-138** brass plug and **SOLID** washers.
- M5 x 0.8H tapped air hole on breather end of ..... E housing **456-139** 90 degree fitting and **SOLID** washers.
- M5 x 0.8H tapped air hole on breather end of ..... F housing **456-140** Straight fitting and **SOLID** washers.
- Micro Dial ..... G
- M5 x 0.8H tapped air hole on breather end of ..... H housing **456-139** 90 degree fitting and **SOLID** washers. Micro Dial.

#### SERVO-METER RATING

- Half drop ..... 05
- Full drop ..... 10
- Two drops ..... 20

#### SERVO-METER HOUSING MATERIAL

- Brass housing..... B
- Aluminum housing ..... A
- Nickle plated housing ..... N

#### PORT TYPE

- NPTF ..... Leave Blank
- BSPF ..... W

#### OPTIONS (More than one option can be chosen. Add in alphabetical order)

- None (remove dash) ..... Leave Blank
- Servo-meter shutoff ..... A
- Non-shutoff ..... Leave Blank
- Oil end seals (**EPR**) ..... E
- Oil end seals (**Neoprene**) ..... N
- Oil end seals (**Viton**) ..... V
- Oil end seals (**Buna N standard**) .... Leave Blank

# SERVO-METERS

## Add-on injectors / replacement kits

### SERVO-METER KITS FOR SERV-OIL ELECTRONICALLY CONTROLLED MULTIPLE-POINT INJECTION LUBRICATORS.

Series 7A0

**70 0 01 10 4 B - W**

**EXTRA PORTING and MICRO DIAL OPTIONS**

Standard Servo-Meter no options ..... 0  
 Micro Dial ..... G

**SERVO-METER RATING**

Half drop ..... 05  
 Full drop ..... 10  
 Two drops ..... 20

**SERVO-METER HOUSING MATERIAL**

Brass housing.....B  
 Aluminum housing ..... A  
 Nickle plated housing ..... N

**PORT TYPE**

NPTF ..... Remove '-'  
 BSPP ..... W

### SERVO-METER KITS FOR AUTOMATION PACS

Series 730

**70 0 01 10 4 B - A W**

**EXTRA PORTING and MICRO DIAL OPTIONS**

Standard Servo-Meter no options ..... 0  
 M5 x 0.8H tapped air hole on breather end of ..... D housing **456-138** brass plug and **SOLID** washers.  
 M5 x 0.8H tapped air hole on breather end of ..... E housing **456-139** 90 degree fitting and **SOLID** washers.  
 M5 x 0.8H tapped air hole on breather end of ..... F housing **456-140** Straight fitting and **SOLID** washers.  
 Micro Dial ..... G  
 M5 x 0.8H tapped air hole on breather end of ..... H housing **456-139** 90 degree fitting and **SOLID** washers. Micro Dial.

**SERVO-METER RATING**

Half drop ..... 05  
 Full drop ..... 10  
 Two drops ..... 20

**SERVO-METER HOUSING MATERIAL**

Brass housing.....B  
 Aluminum housing ..... A  
 Nickle plated housing ..... N

**PORT TYPE**

NPTF ..... Leave Blank  
 BSPP ..... W

**OPTIONS** (*More than one option can be chosen. Add in alphabetical order*)

None (*remove dash*) ..... Leave Blank  
 Servo-meter shutoff ..... A  
 Non-shutoff ..... Leave Blank  
 Oil end seals (**EPR**) ..... E  
 Oil end seals (**Neoprene**) ..... N  
 Oil end seals (**Viton**) ..... V  
 Oil end seals (**Buna N standard**) ....Leave Blank

# SERVO-METERS

## Add-on injectors / replacement kits

### SERVO-METER KITS FOR LIQUID DISPENSERS

Series 740 and 770

**70 0 01 10 4 B - A L V W**

**EXTRA PORTING and MICRO DIAL OPTIONS**

- Standard Servo-Meter no options ..... 0
- M5 x 0.8H tapped air hole on breather end of ..... D housing **456-138** brass plug and **SOLID** washers.
- M5 x 0.8H tapped air hole on breather end of ..... E housing **456-139** 90 degree fitting and **SOLID** washers.
- M5 x 0.8H tapped air hole on breather end of ..... F housing **456-140** Straight fitting and **SOLID** washers.
- Micro Dial ..... G
- M5 x 0.8H tapped air hole on breather end of ..... H housing **456-139** 90 degree fitting and **SOLID** washers. Micro Dial.

**SERVO-METER RATING**

- Half drop ..... 05
- Full drop ..... 10
- Two drops ..... 20

**SERVO-METER HOUSING MATERIAL**

- Brass housing..... B
- Aluminum housing ..... A
- Nickle plated housing ..... N

**PORT TYPE**

- NPTF ..... Leave Blank
- BSPP ..... W

**OPTIONS**

- Oil end seals (**EPR**) ..... Leave Blank  
*(Add E using other OPTION)*
- Oil end seals (**Viton**) ..... V

**OPTIONS** *(More than one option can be chosen. Add in alphabetical order)*

- None *(remove dash)* ..... Leave Blank
- Servo-meter shutoff ..... A
- Non-shutoff ..... Leave Blank
- Oil end seals (**EPR**) ..... E

### SERVO-METER KITS FOR JETMASTER LIQUID DISPENSERS

Series 750 and 760

**70 0 01 10 5 B - E S V**

**EXTRA PORTING and MICRO DIAL OPTIONS**

- Standard Servo-Meter no options ..... 0
- M5 x 0.8H tapped air hole on breather end of ..... D housing **456-138** brass plug and **SOLID** washers.
- M5 x 0.8H tapped air hole on breather end of ..... E housing **456-139** 90 degree fitting and **SOLID** washers.
- M5 x 0.8H tapped air hole on breather end of ..... F housing **456-140** Straight fitting and **SOLID** washers.
- Micro Dial ..... G
- M5 x 0.8H tapped air hole on breather end of ..... H housing **456-139** 90 degree fitting and **SOLID** washers. Micro Dial.

**SERVO-METER RATING**

- Half drop ..... 05
- Full drop ..... 10
- Two drops ..... 20

**OPTIONS**

- Oil end seals (**EPR**) ..... Leave Blank  
*(Add E using other OPTION)*
- Oil end seals (**Viton**) ..... V

**OPTIONS** *(More than one option can be chosen. Add in alphabetical order)*

- None *(remove dash)* ..... Leave Blank
- Servo-meter shutoff ..... A
- Non-shutoff ..... Leave Blank
- Oil end seals (**EPR**) ..... E

**SERVO-METER HOUSING MATERIAL**

- Brass housing..... B
- Aluminum housing ..... A
- Nickle plated housing ..... N

**This page has been  
intentionally left blank**

# SERV-OIL Multiple-Point Injection Lubricators

## Series 710, 720



Model Shown: 71003104B

Up to 10 Servo-Meters can be assembled to make up a multiple point lubricator (**MPL**). Assembled **MPLs** can be ordered, or they can be assembled by the user employing the Servo-Meter and Assembly/Mounting Kits shown on the facing page. Master Pneumatic recommends that you order factory-assembled **MPLs**. The cost is economical, your installation time is greatly reduced, and you are assured of reliable performance because both the components and the assemblies have been factory-tested.

The frequency of oil injection can be controlled by using one of the pulse counters or frequency controllers detailed on page 200.

Series 710 factory assemblies employ two mounting holes. When a very rigid mounting is needed, order Series 720 which employs heavy-duty mounting plates with four mounting holes.

## SPECIFICATIONS

**Ambient/Media Temperature:**

40° to 125°F (4° to 52°C).

**Controller:** See page 200 for the various types of controllers available.

**Operating Pressure:** 60-150 psig (4.1-10.3 bar).

**Reservoir:** See page 222 for the various types of reservoirs available.

**Servo-Meter:** Brass body; optional Aluminum and Nickel plated housings; acetal end caps. 1-Drop rating; optional 1/2-drop or 2-drop rating. Minimum operating air pressure: 60 psig (4 bar).

**Oil Viscosity Range:** 31-1000 @ 100°F (37.8°C)

**DIMENSIONS** inches (mm)

A	B †	C	D	E †
3.9 (99)	2.5 (64)	1.8 (46)	4.1 (104)	4.3 (109)

† Add 0.9 (23) for each additional Servo-Meter.

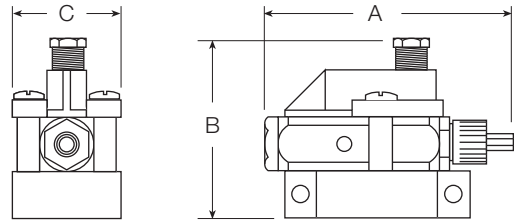

**Without Pulse Counter**

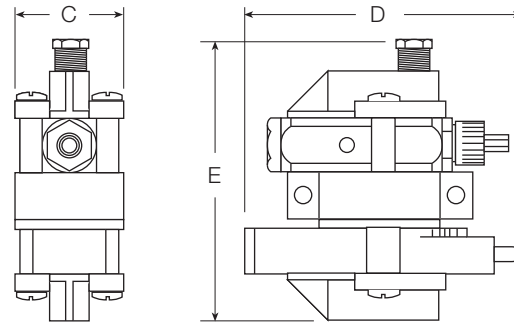

**With Pulse Counter**

**ORDERING INFORMATION**

Change the letters in the sample model number below to specify the **MPL** you want.

**710 01 05 4 B - Y W**

**MPL SERIES**

- Standard MPL assembly..... 710
- MPL assembly with heavy-duty mount..... 720

**NUMBER OF SERVO-METERS**

Specify by numerals  
from 01 to 10

**SERVO-METER RATING**

- Half drop .....05
- One drop.....10
- Two drops .....20

**SERVO-METER HOUSING MATERIAL**

- Brass housing .....B
- Aluminum housing .....A
- Nickel plated brass housing, .....N  
clamp and mounting plate.

**PORT TYPE**

- NPTF threads ..... Leave Blank
- BSPP threads ..... W

**OPTIONS** (*More than one option can be chosen. Add in alphabetical order*)

- None ..... Leave Blank
- Servo-Meter shutoff ..... A
- Non-shutoff ..... Leave Blank
- Block plate; indicate position  
from top with \* ..... B\*
- Pulse counter
  - One..... C
  - Two..... CC
- Oil End Seals (Buna N standard)
  - EPR ..... E
  - Neoprene ..... N
  - Viton ..... V
- Frequency controller ..... F
- and one pulse counter
- Frequency controller only ..... F1

# Electronically Controlled SERV-OIL Multiple-Point Lubricators

## Series 7A0



Model Shown: 7A001204B-2110

The electronically controlled multiple-point lubricator has a 3-way solenoid-controlled valve to produce the actuating signals for the Servo-Meters (up to four may be used.). This allows lubrication control to be interfaced with other system electronics, so that the frequency of oil injection is under precise control.

**Servo-Meters.** Up to four can be included in the assembly with ratings of 1/2, 1, or 2 drops. Each Servo-Meter output is adjustable down to just 10 percent of its rating. Because of their modular construction Servo-Meters can be easily added or removed from the assembly.

**Pneumatic Valve.** A solenoid-actuated, 3-way valve provides the air pressure to actuate the Servo-Meters. Inlet pressure must be at least 60 psig (4 bar). Available solenoid voltage options are 24-, 110-, or 220-volts AC and 12-, 24-, or 110-volts DC.

**Oil Supply.** Oil can be supplied from a central reservoir, or an optional integral reservoir. Integral reservoirs are available in 10-ounce (part **M476R**), one-quart (part **M570-6R**), or two-quart (**M570-12R**) capacities.

**Air Filter.** A general-purpose Sentry filter can be included in the assembly, but is not required if external air filtration is adequate, i.e., has at least 40- $\mu$ m filtration.

## SPECIFICATIONS

**Ambient/Media Temperature:**

40° to 125°F (4° to 52°C).

**Operating Pressure:** 60-150 psig (4.1-10.3 bar).

**Pneumatic Valve:** Solenoid actuated 3-way. Electrical: 24-, 120-, 220-volts 50/60 Hz; 12-, 24-, 110-volts DC.

**Servo-Meter:** Brass body; optional Aluminum and Nickel plated housings; acetal end caps. 1-Drop rating; optional 1/2-drop or 2-drop rating. Minimum operating air pressure: 60 psig (4 bar). Transparent sight indicator gives visual verification of oil delivery.

**Oil Viscosity Range:** 31-1000 @ 100°F (37.8°C)

## IMPORTANT SERIES 7A0 BENEFITS

Modular design provides Servo-Meters, solenoid valve, and air filter in a complete package with easy add-on capability.

There is no need to purchase additional valves or other components. Simply pipe up an air supply and plug in the **MPL** package.

You have full control by coordinating with your own computer programming. This eliminates costly feast-or-famine lubrication.

## EASY ORDERING FOR SERIES 7A0

Model Number	Servo-Meters	Inlet Port
7A00#054B-11XY	1/2 drop	1/8 NPTF
7A00#054B-21XY	1/2 drop	1/4 NPTF
7A00#104B-11XY	1 drop	1/8 NPTF
7A00#104B-21XY	1 drop	1/4 NPTF
7A00#204B-11XY	2 drops	1/8 NPTF
7A00#204B-21XY	2 drops	1/4 NPTF

# – Insert quantity of Servo-Meters (1 to 4).  
 X – Insert voltage number (see Ordering Information below).  
 Y – Insert filter number (see Ordering Information below).

## DIMENSIONS inches (mm)

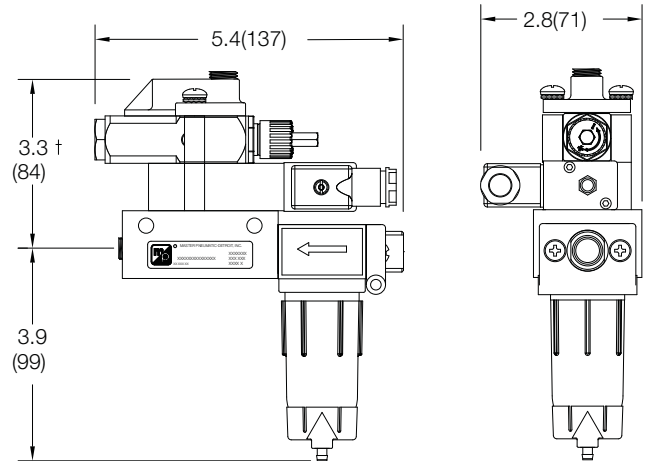

† ADD 0.9 (23) FOR EACH ADDITIONAL SERVO-METER

## ORDERING INFORMATION

Change the letters in the sample model number below to specify the **MPL** you want.

**7A0 01 05 4 B - 1 1 1 0 W**

### MPL SERIES

### NUMBER OF SERVO-METERS

Specify by numerals  
 from 01 to 04

### SERVO-METER RATING

Half drop ..... 05  
 One drop ..... 10  
 Two drops ..... 20

### SERVO-METER HOUSING MATERIAL

Brass housing ..... B  
 Aluminum housing ..... A  
 Nickel plated brass housing, ..... N  
 clamp and mounting plate.

### INLET PORT SIZE

1/8 NPTF ..... 1  
 1/4 NPTF ..... 2

### DIN 4360 Form B Option ..... 1

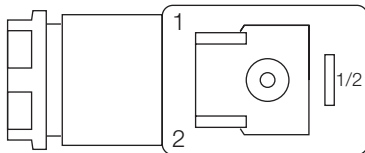

### PORT TYPE

NPTF threads ..... Leave Blank  
 BSPB threads ..... W

### FILTER

Standard Sentry filter ..... 0  
 No filter; female side port ..... 1

### VOLTAGE

120 volts, 50/60 Hz ..... 1  
 24 volts, DC ..... 2  
 24 volts, 50/60 Hz ..... 3  
 220 volts, 50/60 Hz ..... 4  
 12 volts, DC ..... 5  
 110 volts, DC ..... 6

Normal Polarity:  
 1 = (+) positive, high  
 2 = (-) negative, neutral  
 1/2 = chassis ground

**NOTE:** Optional automotive standard to mini plug is available. Consult Master Pneumatic.



# SERV-OIL Automation Pacs

# Series 730

Model Shown: 73010104B-CC



**Automation Pac with Double-Counter Controller  
For Use with Pulse Air Inlet Source**

Model Shown: 73010104B-F



**Automation Pac with Frequency Controller  
For Use with Constant Air Inlet Source**

A **SERV-OIL** Automation Pac is a self-contained assembly of oil reservoir, up to 20 Servo-Meters, and a controller. It is supplied ready for installation in a pneumatic circuit, with only ball checks, fittings, and tubing being required. The Automation Pac will provide precision lubrication for up to 20 points on valves, cylinders, fixtures, automation equipment, and machine tools using pneumatic components.

**Oil Reservoir.** The Automation Pac oil reservoir is made of cast aluminum, and has a capacity of 1/2 gallon (1.9 liters). It has a built-in oil strainer, a transparent sight tube, a quick-fill cap, and a screw-on lid.

If the Automation Pac is located where the oil level cannot easily be determined visually, electrical oil-level switches are available. There are both high-level and low-level switches. They can be connected to a remote electrical control for automatic filling of the reservoir.

**Controllers:** (See page 200.) Double pulse counters, with or without a frequency generator, can be used to control the frequency of oil injection. These can be integrated into the assembly, or be in the form of stand-alone controllers. A stand-alone controller can be employed to control the injection frequency of several Automation Pacs.

In either case actuation pulses from the system control valve initiate the oil injection function. The controller then is set so the actual oil injection could be every cycle, or every 5, 10, 25, 50, or 100 cycles of the control valve.

Both types of controller are supplied with a 0.3- $\mu$ m coalescing filter for clean, long-life operation. The coalescing filter should be preceded by 5- $\mu$ m filtration to prolong the life of the coalescing element.

## SPECIFICATIONS

**Ambient/Media Temperature:**

40° to 175°F (4° to 79°C).

**Reservoir:** Aluminum; 0.5 gallon (1.9 liters) capacity.

**Seals:** Nitrile.

**Servo-Meter:** Brass body; optional Aluminum and Nickel Plated brass; acetal end caps.

**Servo-Meter Operating Pressure:**

60-150 psig (4.1-10.3 bar).

**Oil Viscosity Range:** 31-1000 @ 100°F (37.8°C)

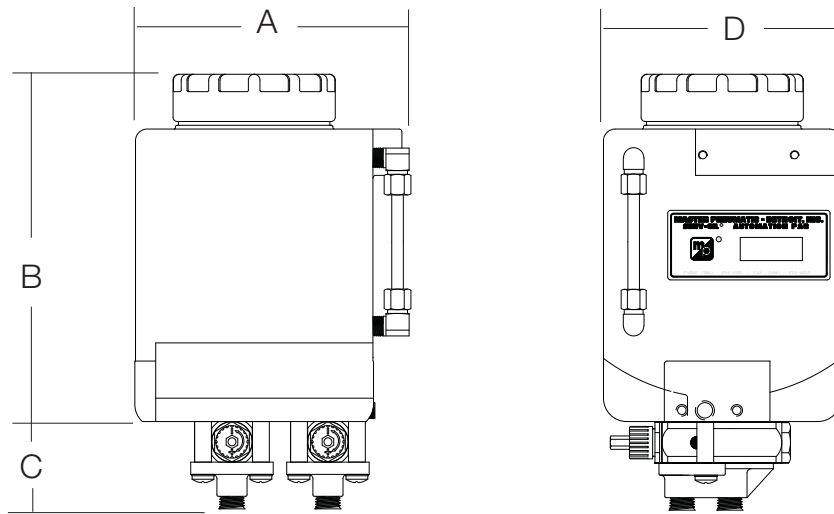

**DIMENSIONS** inches (mm)

				<b>Weight</b>
<b>A</b>	<b>B</b>	<b>C †</b>	<b>D</b>	<b>lb (kg)</b>
5.1 (130)	7.6 (193)	1.8 (46)	5.1 (130)	6.6 (3.0)

† Dimension for single Servo-Meter. For each additional Servo-Meter add 0.9 (23).

**ORDERING INFORMATION**

Change the letters in the sample model number below to specify the Automation Pac you want.

**730 01 05 4 B -Y W**

**AUTOMATION PAC SERIES**

**NUMBER OF SERVO-METERS**

Specify by numerals  
from 01 to 20

**SERVO-METER RATING**

- Half drop ..... 05
- One drop ..... 10
- Two drops ..... 20

**SERVO-METER HOUSING MATERIAL**

- Brass housing ..... B
- Aluminum housing ..... A
- Nickel plated brass housing ..... N  
and clamp.

**PORT TYPE**

- NPTF threads ..... Leave Blank
- BSPP threads ..... W

**OPTIONS** (*More than one option can be chosen. Add in alphabetical order*)

- None ..... Leave Blank
- Servo-Meter shutoff ..... A
- Non-shutoff ..... Leave Blank
- Block plate ..... B  
(Consult Master Pneumatic)
- Two pulse counters ..... CC
- Oil-end seals for Servo-Meter  
(Buna N standard)
- EPR ..... E
- Viton ..... V
- Frequency controller ..... F  
and one pulse counter
- Frequency controller only ..... F1
- Oil-level switches:
- Low-level only ..... G
- High-level and low-level ..... GG

# Serv-Oil PNEUMATIC INJECTION LUBRICATION CHART

Counter Setting	Set at number 1	*Set at 5	Set at 10	Use 2 counters. Set at 5
Servo-Meter setting with <b>one drop (.030 ml)</b> maximum model	Set at one full Drop	Set at 25 clicks from full	Set at 25 Clicks from full	Set at 20 clicks from full

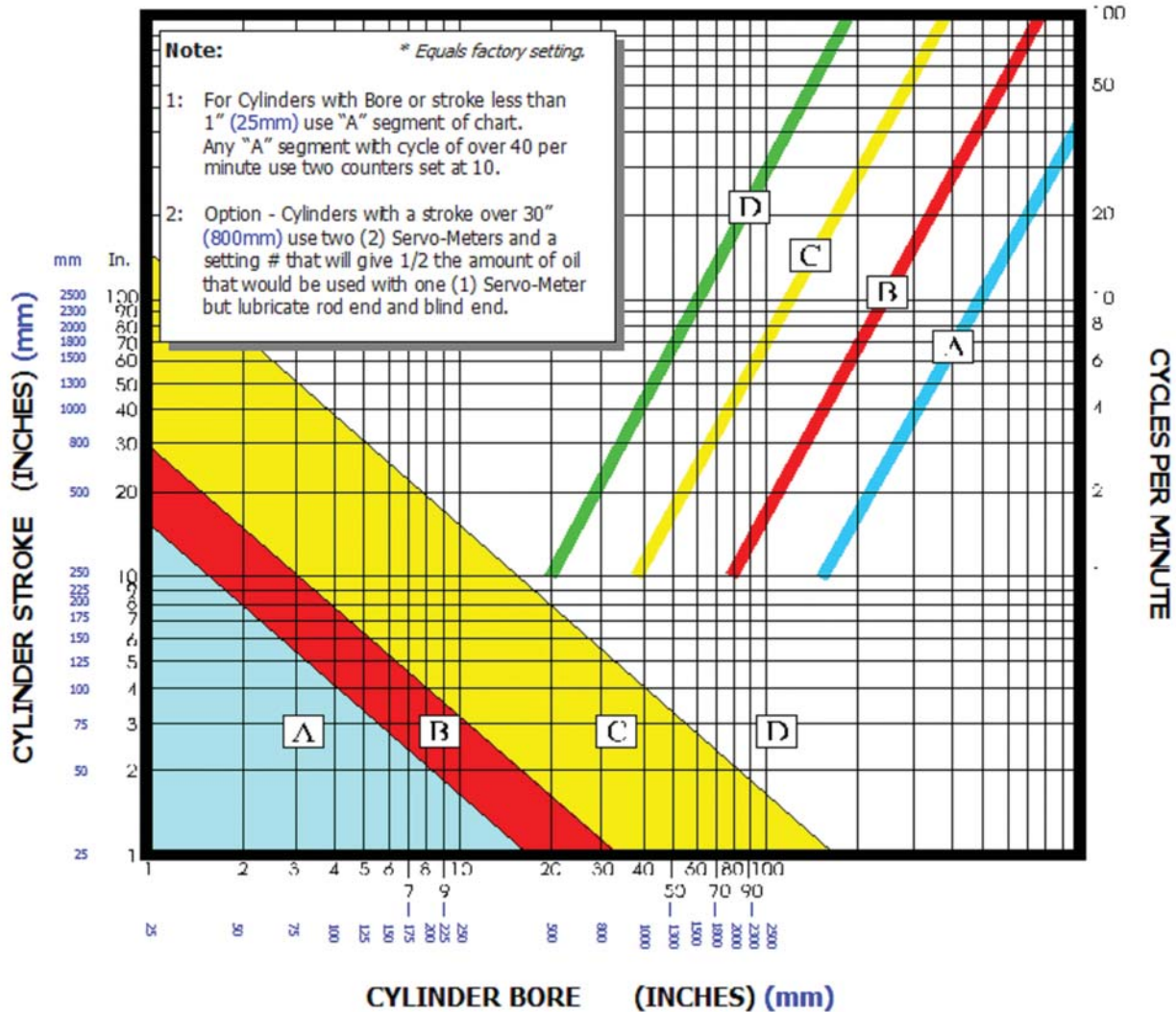

First identify where the bore and stroke intersect on the lower chart. With the appropriate letter use the cycles of the cylinder per minute and draw a line to intersect the A, B, C or D line on the upper chart. Draw a line vertically from there to the appropriate setting of the counter and Servo-Meter.

**Example:** Cylinder with 4" bore and 5" stroke falls into the "B" segment of the selection chart. If the operating rate of the cylinders is 15 per minute, the counter setting should be at 10 and the injector (*Servo-Meter*) knob turned counter - clockwise 25 clicks.

To increase Servo-Meter output, turn volume control knob clockwise. **NOTE:** This chart is a tool for establishing a baseline only. Specific applications may require more or less fluid output.

MASTER PNEUMATIC - DETROIT, INC. SERV-OIL ACTUATOR SELECTION CHART.

## MULTIPLE POINT LUBRICATOR'S (MPL's) with M476R RESERVOIR



71001104B-C with M476R reservoir



71002104A with M476R reservoir

# Liquid Dispensers

# Series 740, 770



Model Shown: 74004204B-ALV

## SPECIFICATIONS

**Ambient/Media Temperature:**

40° to 125°F (4° to 52°C).

**Inlet Pressure:** 60 to 120 psig (4 to 8 bar).

**On/Off Control:** Manual.

**Servo-Meter Body:** Brass Body; optional Aluminum and Nickel plated brass; zinc end plates.

**Servo-Meter Seals:**

Nitrile on air end; viton on oil end.

The Series 740 liquid dispenser employs Servo-Meters to send precise amounts of liquid through nozzles. It is primarily used where liquid without entrained air is wanted, and a precisely controlled jet is not required. Up to 10 Servo-Meters can be used in a single assembly. A pressure of at least 60 psig (4 bar) is required for actuation.

1/8-Inch O.D. nylon tubing carries the oil from a Servo-Meter to a nozzle [5/64" (2-mm) orifice] located near the delivery point.

**Install a liquid-only dispenser so that the Servo-Meters are vertical and the outlets are at the top.** This helps to eliminate air from the system. The nozzles need to be secured in place with a clamp or similar means.

Series 740 factory assemblies employ two mounting holes. When a very rigid mounting is needed, order Series 770 which employs heavy-duty mounting plates with four mounting holes.

Liquid dispenser assemblies can be ordered, or they can be assembled by the user employing the Servo-Meter and Assembly/Mounting Kits shown on the facing page.

*Master Pneumatic recommends that you order factory-assembled dispensers. The cost is economical, your installation time is greatly reduced, and you are assured of reliable performance because both the components and the assemblies will have been factory-tested.*

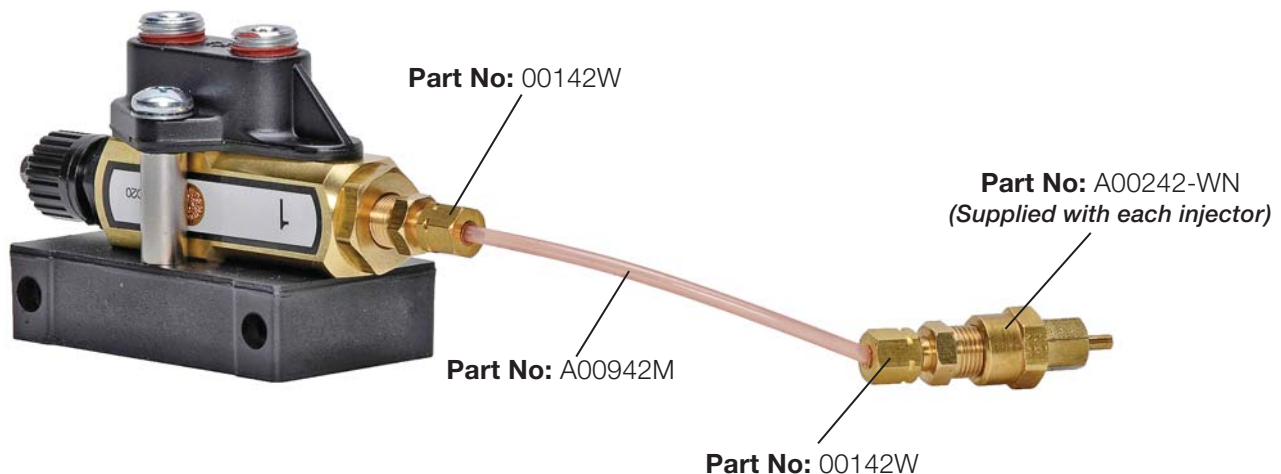

**DIMENSIONS** inches (mm)

A	B †	C
3.9 (99)	2.5 (64)	1.8 (46)

† Add 0.9 (23) for each additional Servo-Meter.

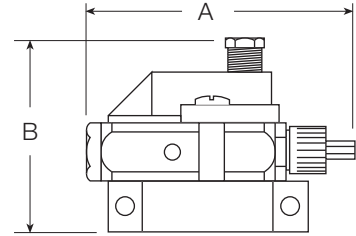
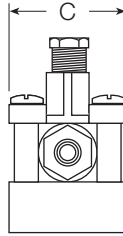

**LIQUID DISPENSER ASSEMBLY KITS**

Mounting/Assembly Kit

KA474-10

Mounting/Assembly Kit

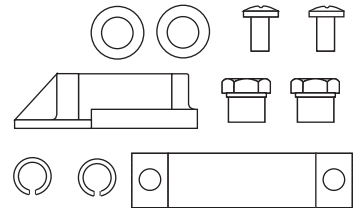

**ORDERING INFORMATION**

Change the letters in the sample model number below to specify the Liquid Dispenser you want.

**740 01 05 4 B - Y L V W**

**LIQUID EJECTOR SERIES**

- Assembly with standard mount ..... 740
- Assembly with heavy-duty mount..... 770

**NUMBER OF SERVO-METERS**

Specify by numerals from 01 to 10

**SERVO-METER RATING**

- Half drop ..... 05
- One drop ..... 10
- Two drops ..... 20

**SERVO-METER HOUSING MATERIAL**

- Brass housing ..... B
- Aluminum housing ..... A
- Nickel plated brass housing, ..N clamp and mounting plate.

**PORT TYPE**

- NPTF threads ..... Leave Blank
- BSPB threads ..... W

**OPTION**

- Oil end seals for Servo-Meter
- Viton ..... V
- EPR ..... Leave Blank
- (Also add E option located under **OPTIONS**).

**OPTIONS** (More than one option can be chosen. Add in alphabetical order)

- None ..... Leave Blank
- Servo-Meter shutoff ..... A
- Non-shutoff ..... Leave Blank
- Pulse counters
- One ..... C
- Two ..... CC
- Oil End Seals for Servo-Meter
- EPR ..... E
- Frequency controller ..... F
- and one pulse counter
- Frequency controller only ..... F1

# SERV-OIL JETMASTER Liquid Dispenser Propels Conical Air-Liquid Jets

**Series 750,  
760**

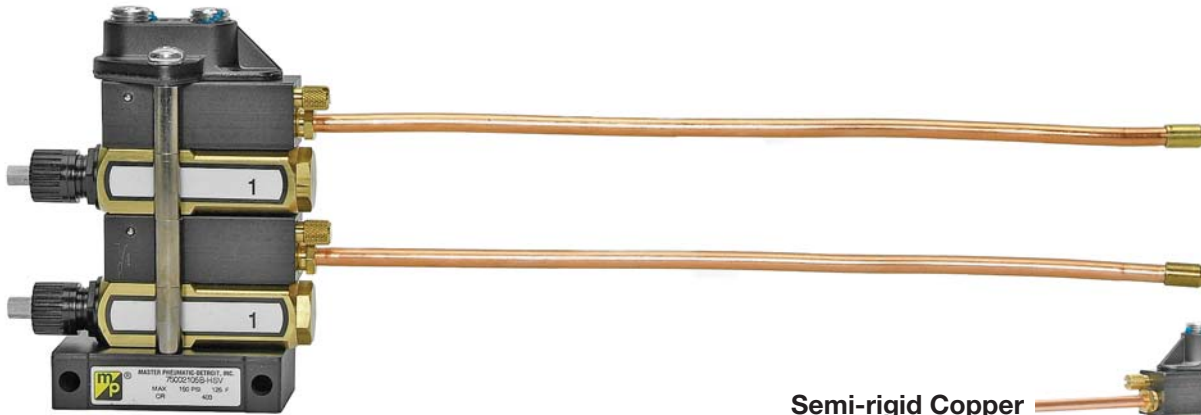

**Model Shown:** 75002105B-HSV

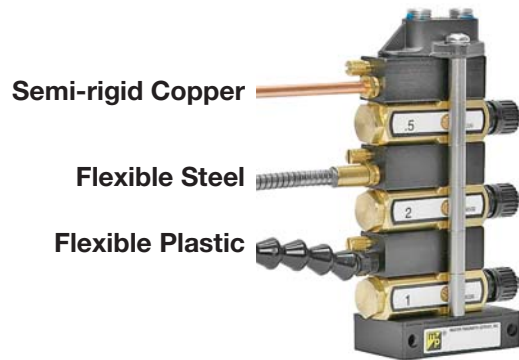

The Serv-Oil Jetmaster Liquid Dispenser is used for the controlled application of many types of liquids. Light, chemically non-aggressive spindle lubricating oil, however, is the most commonly used liquid\*.

The Jetmaster employs a Servo-Meter and a nozzle to propel a conical air-liquid jet up to 10 inches (25 cm) with pinpoint accuracy, and with no drip or overspray. The amount of liquid and the amount of air in the jet are independently adjustable. The Jetmaster is actuated by an air pulse (usually from a valve), and controllers are available to determine the frequency with which a jet is propelled. Viton seals are standard.

### Multiple Jetmaster Dispensers

Assemblies may be ordered with up to five Servo-Meters and five nozzles. All can be actuated simultaneously by a single air signal of 60 psig (4 bar).

To increase the amount of liquid in a single jet, multiple Servo-Meters can feed through a single nozzle. Consult Master Pneumatic for further information.

### Nozzles

Twelve-inch nozzles are standard, but other lengths can be special ordered. The standard copper tube nozzles can be bent in any direction to dispense liquid at the point of need. Teflon tubing running through the nozzle carries the liquid to the nozzle end where it is propelled from the tubing by the air jet passing around it. An air metering adjustment screw is provided for each nozzle.

### JETMASTER NOZZLE ASSEMBLIES

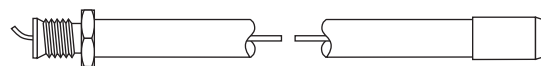

**Semi-rigid Copper** (Standard - suffix H)

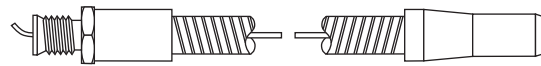

**Flexible Steel** (Optional - suffix M)

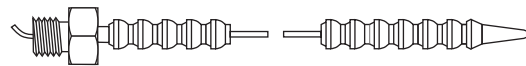

**Flexible Plastic** (Optional - suffix K)

\*Contact M/P for fluid compatibility.

**DIMENSIONS** inches (mm)

A	B †	C
3.5 (89)	3.4 (86)	1.8 (46)

† Add 0.9 (23) for each additional Servo-Meter.

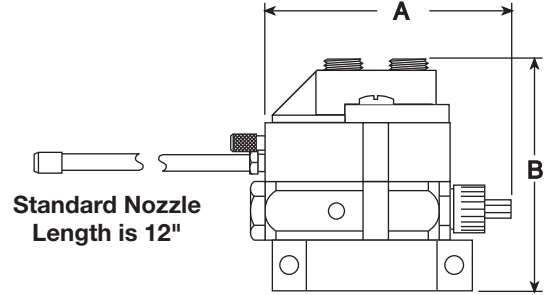
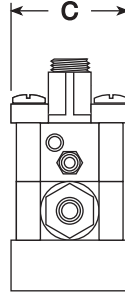

**LIQUID DISPENSER ASSEMBLY KITS**

Mounting/Assembly Kit

KA474-10

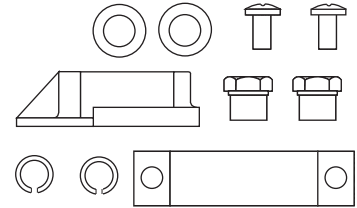

Mounting/Assembly Kit

**ORDERING INFORMATION**

Change the letters in the sample model number below to specify the Liquid Dispenser you want.

**750 01 05 5 B - Y H 00 S V W**

**JETMASTER SERIES**

Standard Jetmaster ..... 750  
 Jetmaster with heavy-duty ..... 760  
 mount.

**NUMBER OF SERVO-METERS**

Specify by numerals  
 from 01 to 05

**SERVO-METER RATING**

Half drop ..... 05  
 One drop ..... 10  
 Two drops ..... 20

**SERVO-METER HOUSING MATERIAL**

Brass housing ..... B  
 Aluminum housing ..... A  
 Nickel plated brass housing, ..... N  
 clamp and mounting plate.

**PORT TYPE**

NPTF threads ..... Leave Blank  
 BSPP threads ..... W

**OPTION**

Oil end seals for Servo-Meter  
 Viton ..... V  
 EPR ..... Leave Blank  
 Also add E option located  
 under **OPTIONS**).

**NOZZLE LENGTH**

Length of copper nozzle if other than 12"

**NOZZLE TYPE**

Standard 12" flexible  
 copper nozzle ..... H  
 12" flexible  
 plastic nozzle ..... K  
 12" flexible  
 steel nozzle ..... M

**OPTIONS** (More than one option can be chosen. Add in alphabetical order)

None ..... Leave Blank  
 Servo-Meter shutoff ..... A  
 Non-shutoff ..... Leave Blank  
 Pulse counters  
 One ..... C  
 Two ..... CC  
 Oil End Seals for ..... E  
 Servo-Meter EPR.  
 Frequency controller ..... F  
 and one pulse counter  
 Frequency controller only ..... F1