

 **storm**
Hand Dryer

**HYGIENIC
EXTRAVAGANT
ERGONOMIC**

**10 - 15
SECOND
DRY TIME**

**ADA COMPLIANT
HEPA FILTER
ION + COATING
LED SENSOR**



storm

Hand Dryer



TECHNICAL SPECIFICATIONS

MATERIAL	Polycarbonate ABS (ION+)
MOTOR TYPE	1HP Brush Type, Dual Ball Bearings
THERMAL PROTECTION	450W, on/off option, thermostat protection
OPERATING AIRFLOW	19,869 LFM, Adjustable
AIR OUTPUT TEMP	113F (45C) Ambient Temp. 68F (20C)
SOUND LEVEL	66.1dB
ISOLATION	Class 1
DRIP PROOF	IP23
WATTS	1200 W (750W with heater off)
RPM	11,000-20,000, Adjustable
MOUNTING	Surface
WEIGHT	24lbs

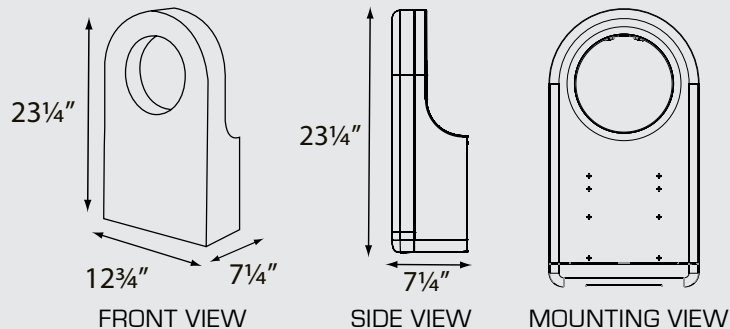

MOUNTING HEIGHTS from bottom of dryer to floor

MEN	48"
WOMEN	45"
CHILDREN (AGES 3-10)	37"
CHILDREN (AGES 11-18)	42"
DISABLED	35.5"

DIMENSIONS

24.60" H x 12.75" W x 7.25" D

WEIGHT

24 lbs

iStorm EXTRAS

FILTER	SP098099-002
BACKSPASH KIT	SP098099-050
BACKSPASH PLATE	SP098099-051

PRODUCT FEATURES

- Incredible 10-15 second dry time
- Ergonomically designed, this reduces uncomfortable bending
- Water absorbing ceramic backspash prevents wet floors and water damage
- Super 3-layer HEPA filter eliminates over 99% of airborne bacteria
- Adjustable airspeed for custom settings to maximize efficiency
- Antibacterial coating reduces the ability for micro-organisms to grow
- On/Off switch for heater so air temp is appropriate for all climates
- 5 Year Limited Warranty

COLOR OPTIONS:

08 Platinum **16** Black **17** White