

Dual Action Pulley

Installation Standard Instruction



Dual Action Pulley Assembly

Step NO	
1	Base
Step NO	
2	Top Beams & Weight Stack
Step NO	
3	Both Cables
Step NO	
4	Stainless Steel Beams, Plates & Pulleys
Step NO	
5	Storage Poll
Step NO	
6	Pull Up Bar
Step NO	
7	Stickers & Branding Plate

Assembly steps

Steps	No.	Name	QTY	project number	Name	QTY
1	4	Right base welding group	1	M	M10Locknut	1
	3	Rear column assembly	1	J	Ø10Gasket	3
	5	Left base welding group	1	I	M10*20Hexagon socket head screws	2
				A	M10*70Hexagon socket flat head screws	1

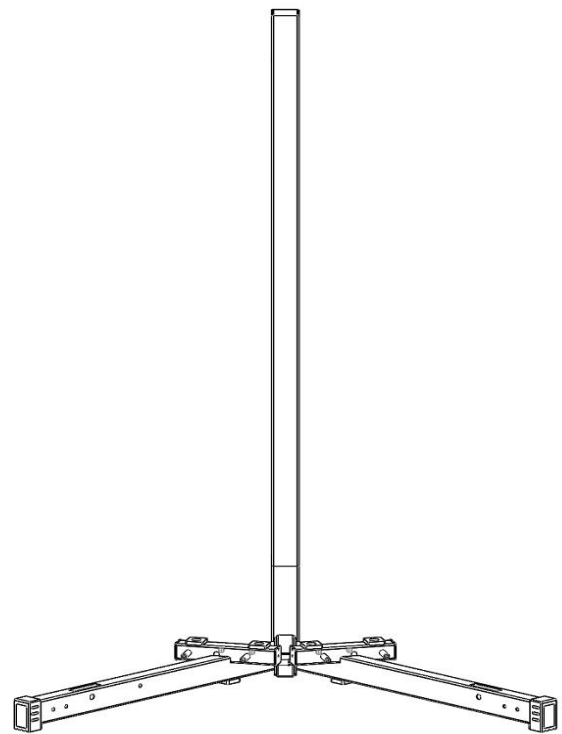
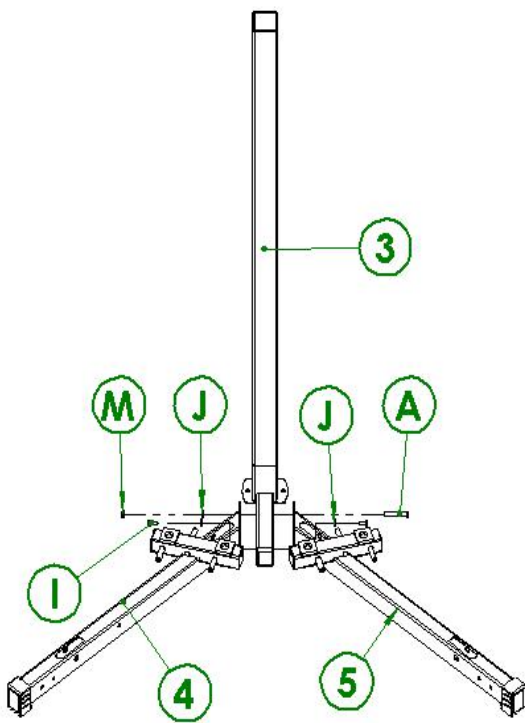

Important Information : You will require access to the rear of the main frame to assemble the pulley wheels and branding plate. Please ensure you leave enough space to allow for this when installing

Top Weight Plate Assembly / 2 pcs						
Step NO	Item NO	Name	Qty	Item NO	Name	Qty
2	No.76	Counterweight guide sleeve	2			
	No.78	Counterweight head	1			

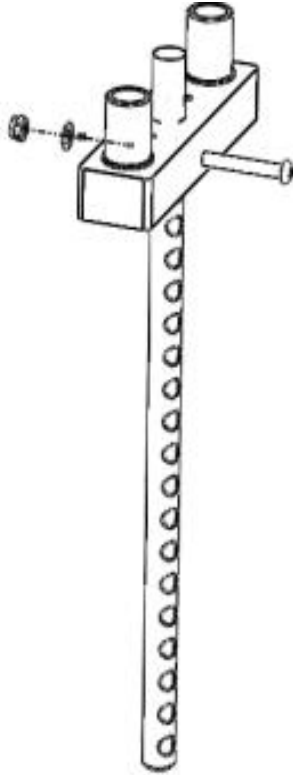

Assembly steps

Step NO	Item NO	Name	Qty	Item NO	Name	Qty
2	No.12	Cast iron counter plate	2	B	M10*100 Hexagon socket flat round head screw	2
	No.23	Optical axis fixed block	2	J	Ø10shim	2
	No.22	Guide rodΦ25	4	E	M10 * 30 round head hexagon screw	4
	No.29	Circular damping pad	4	M	M10jam nut	2
	No.6	Top welding group right	1	No.7	Top weld group left	1
	No.58	Cast iron weight plate	38	58		38

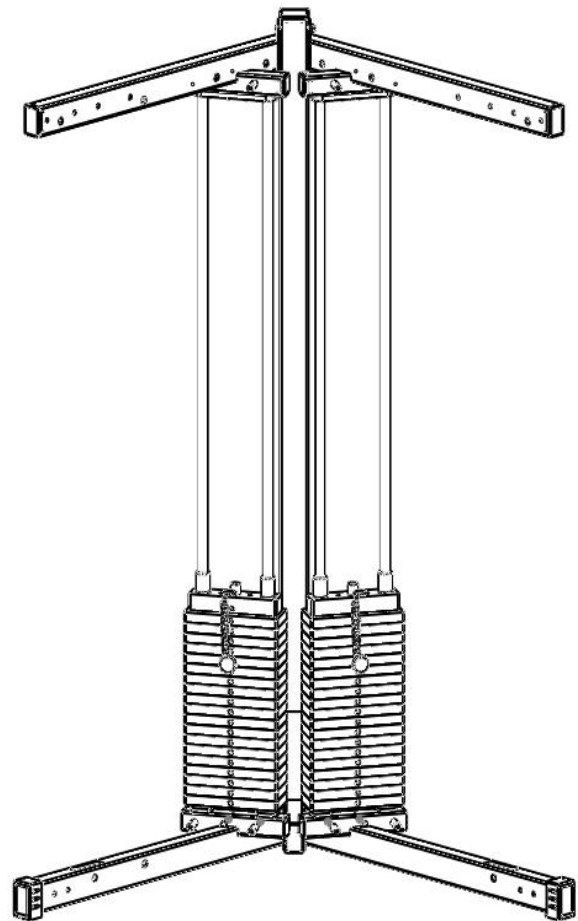
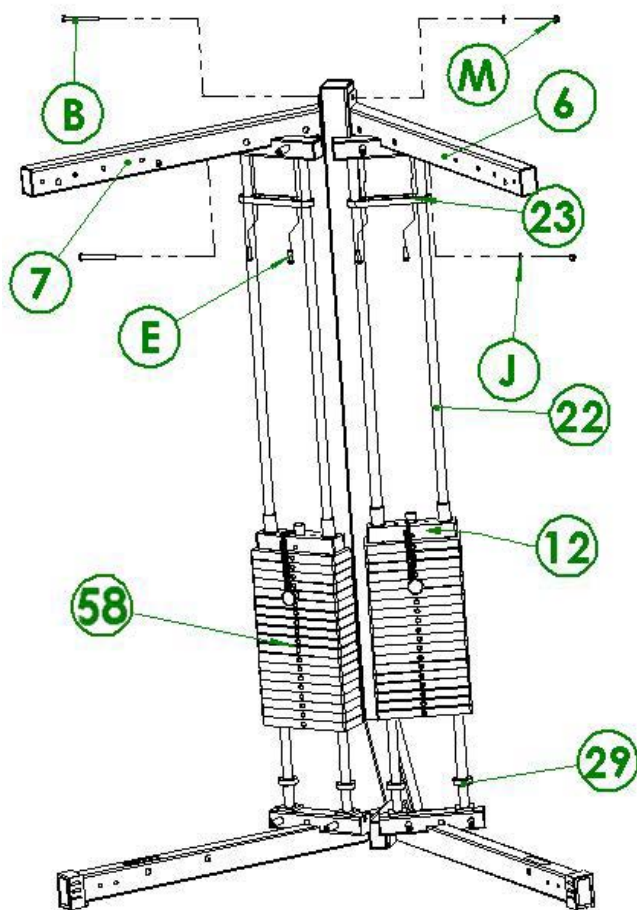

Assembly steps

Step NO	Item NO	Name	Qty	Item NO	Name	Qty
3	No.28	Rubber cover	2	F	M10 * 20 hexagon socket flat round head screw	2
	No.24	Φ 90 pulley	10	M	M10 jam nut	2
	No.57	wire rope	2	J	Ø 10 gasket	2

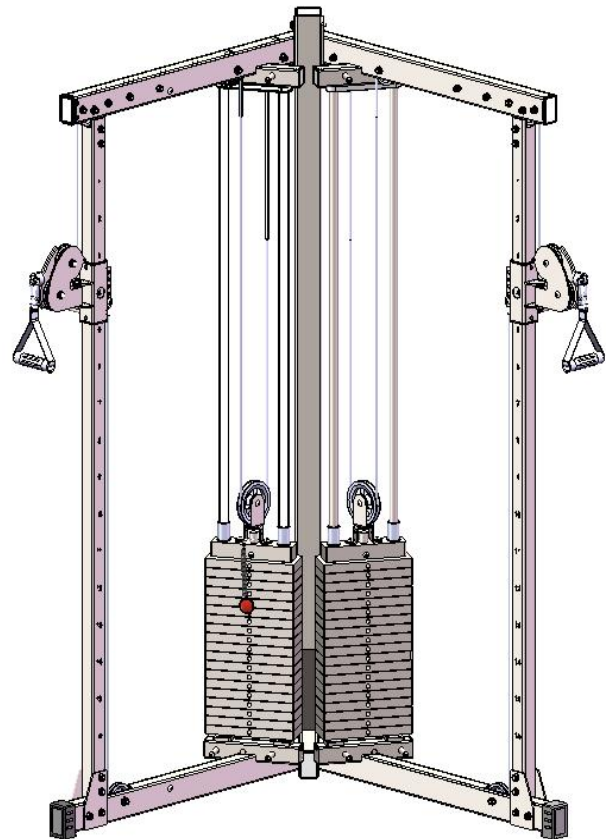
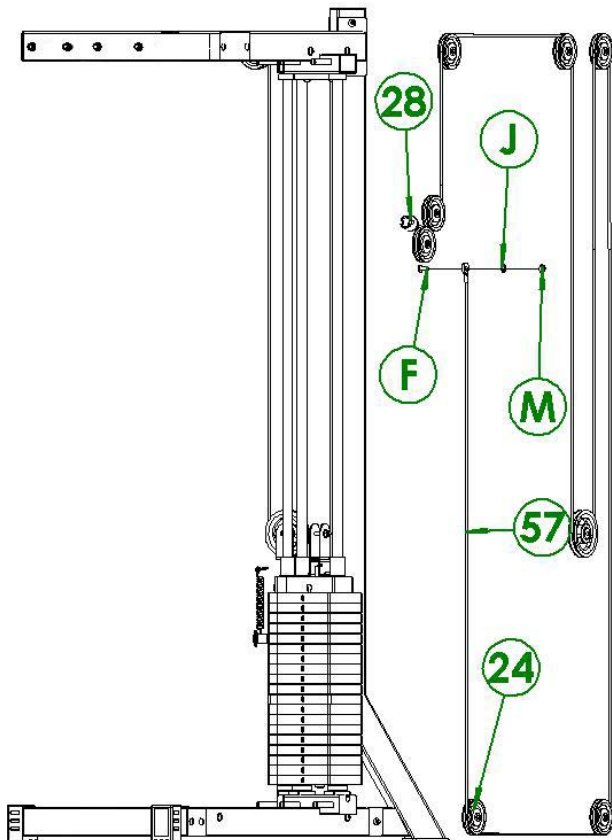

Assembly steps

Step NO	Item NO	Name	Qty	Item NO	Name	Qty
4	No.1	Crossfit pulley assembly left	1	C	M10 * 70 hexagon flat round head screw	8
	No.2	Crossfit pulley assembly right	1	J	Ø 10 gasket	8
	No.16	Lower assembly plate	4	M	M10jam nut	8
	No.18	Stainless steel lettering tube	2			

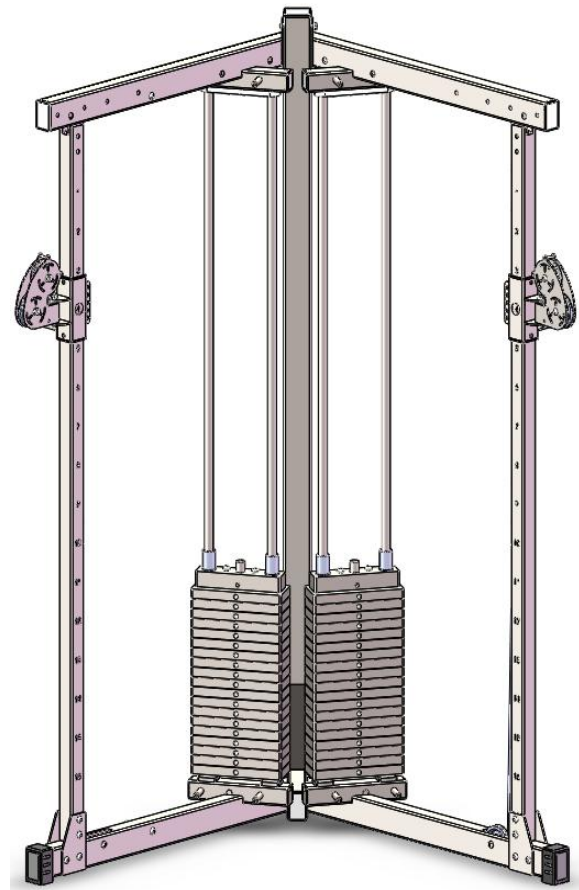
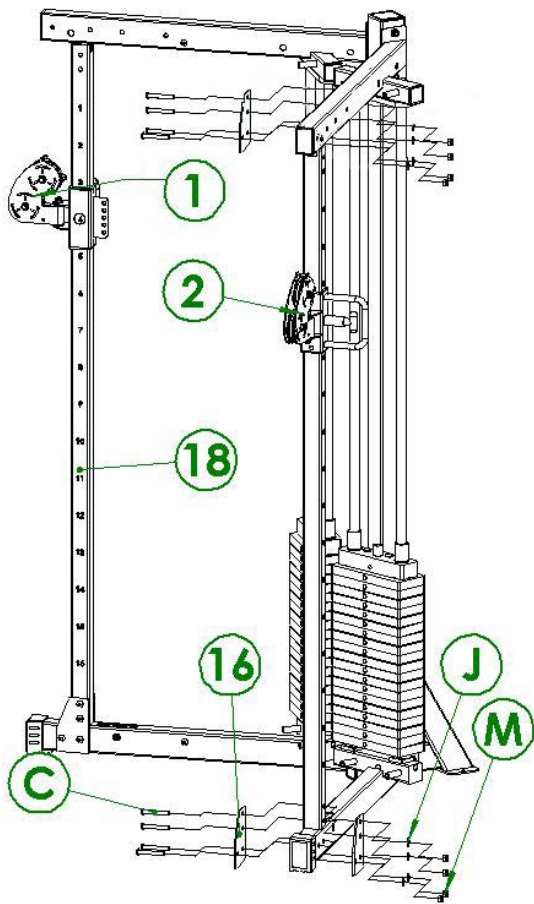

Assembly steps

Step NO	Item NO	Name	Qty	Item NO	Name	Qty
5	No.34	Pulley limit sleeve	20	J	Ø 10 gasket	14
	D	M10 * 65 hexagon socket flat round head screw	10	No.10	Lifting pulley assembly right	1
	F	M10 * 20 hexagon socket flat round head screw	4	No.11	Lifting pulley assembly left	1
	M	M10jam nut	10			

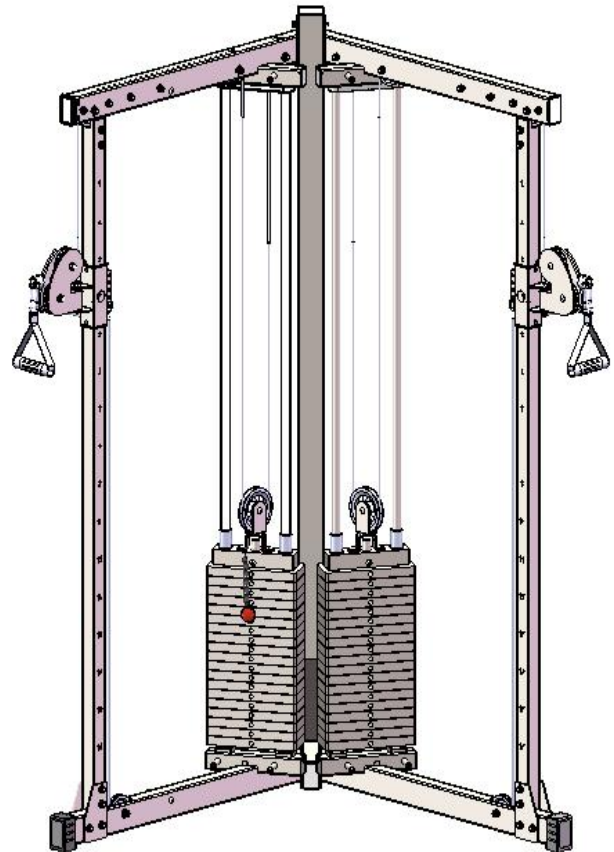
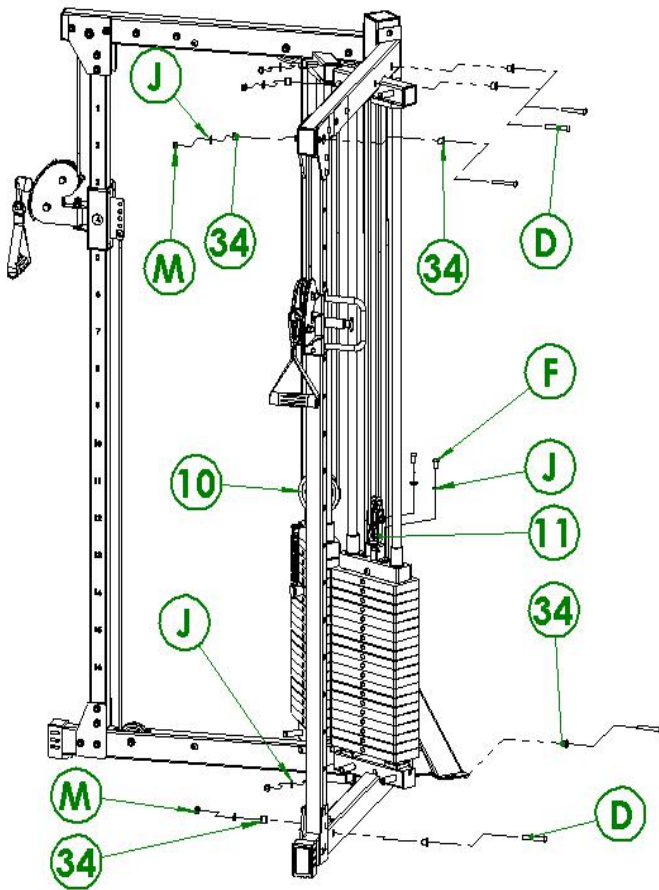

Assembly steps

Step NO	ITEM NO	Name	Quantity	ITEM NO	Name	Quantity
6	NO.8	Beam as-upper	1	J	Ø10shim	12
	NO.17	Small assembly plate	2			
	NO.15	Upper assembly plate	4			
	C	M10*70Hexagon socket flat round head screw	12			
	M	M10Lock nut	12			

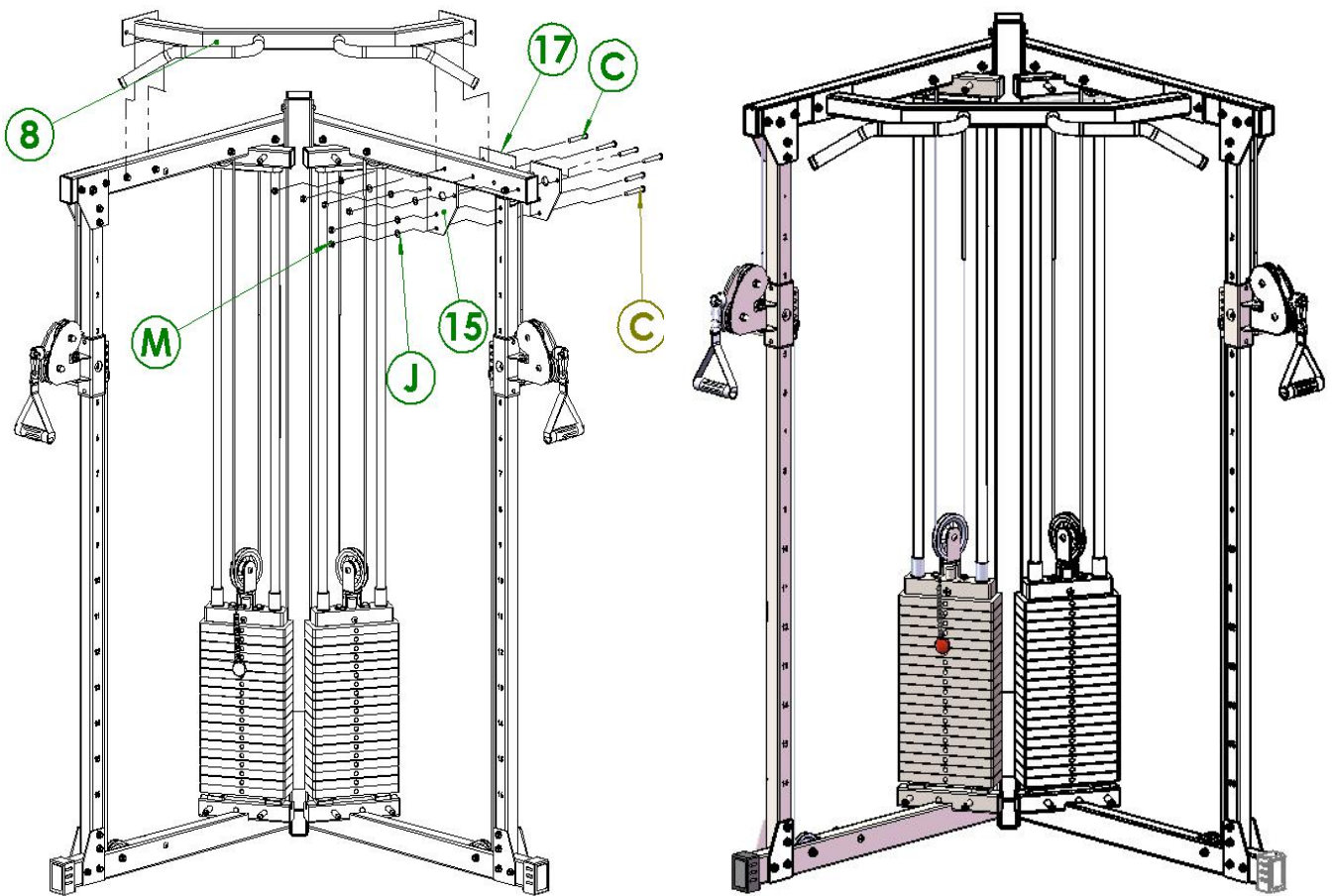

Assembly steps

Step NO	ITEM NO	Name	Quantity	ITEM NO	Name	Quantity
7	NO.30	Clip sleeve	4	A	M10*100Hexagon socket flat round head screw	2
	NO.9	Storage pipe welding group	1	G	M8*20Hexagon socket flat round head screw	10
	NO.31	Plastic hook	6	J	Ø10shim	2
				M	M10Lock nut	2

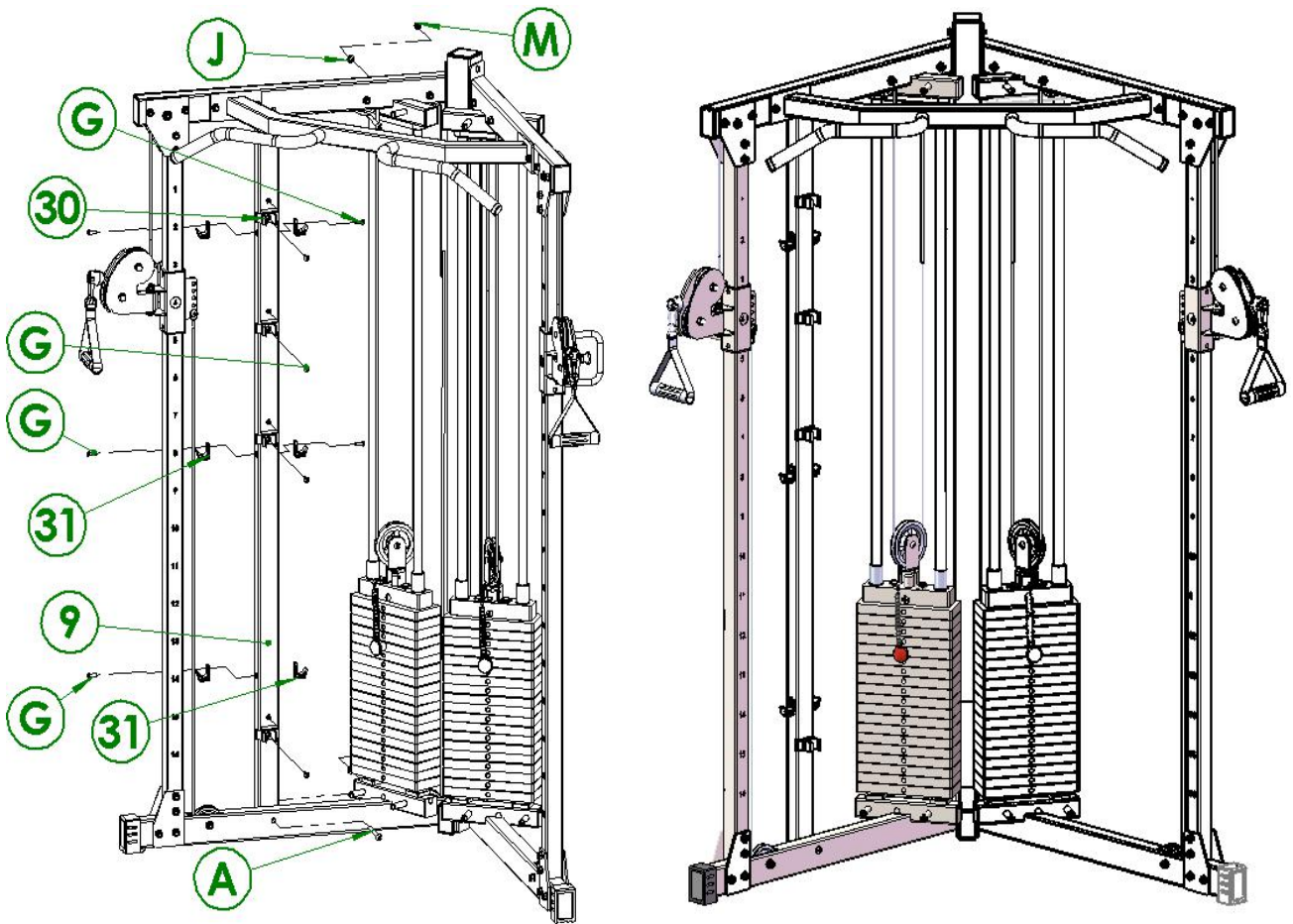

Assembly steps

Step NO	ITEM NO	Name	Quantity	ITEM NO	Name	Quantity
7	NO.14	Low tension welding group	1	NO.21	Front guard	1
	NO.13	Push rod welding group	1	K	Ø8shim	12
	NO.19	Side guard left	1	H	M8*16Hexagon socket flat round head screw	12
	NO.20	Side guard right	1			

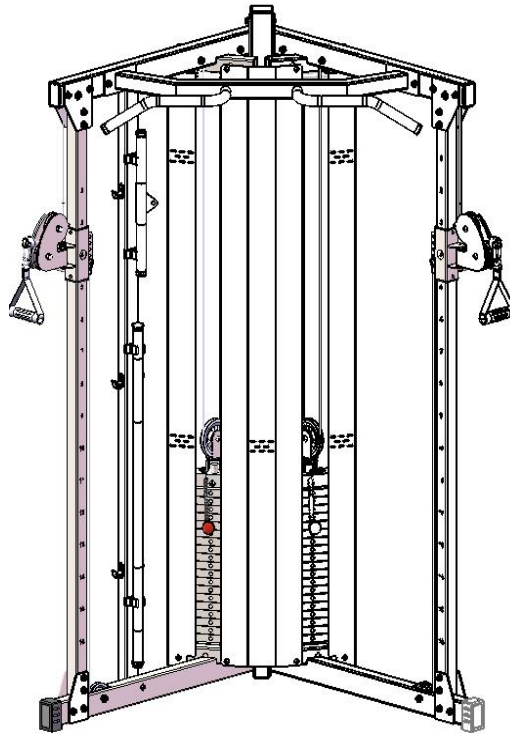
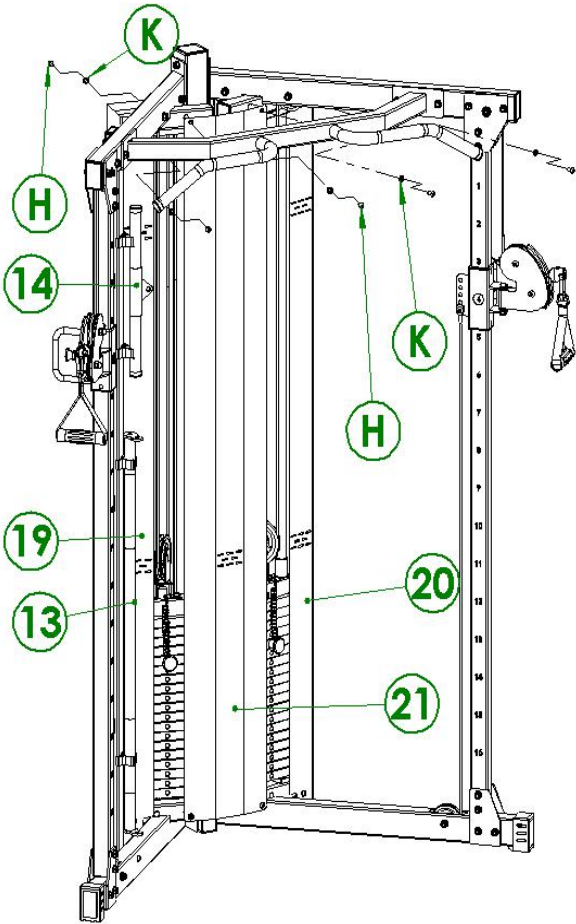



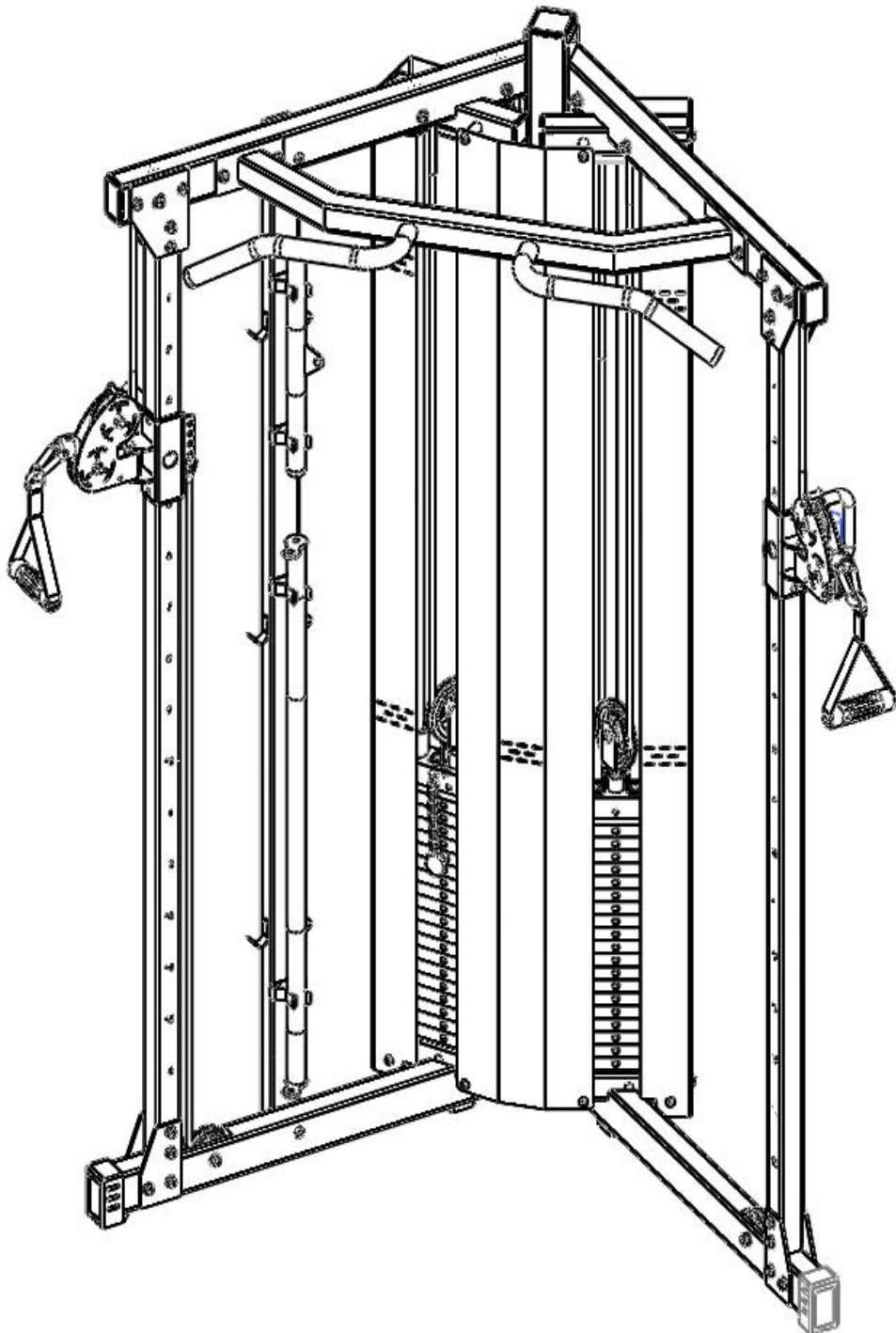



Dual Action Pulley

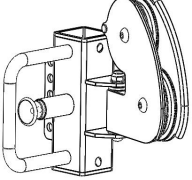
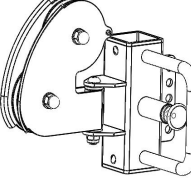

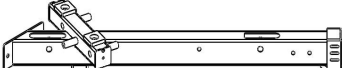

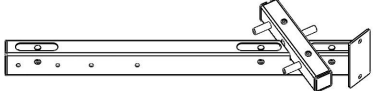
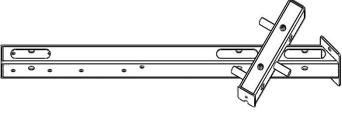
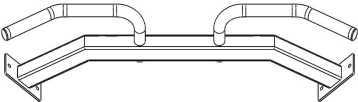

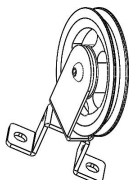
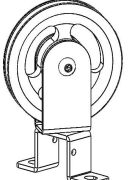
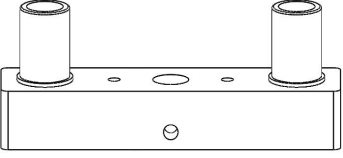
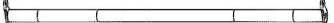
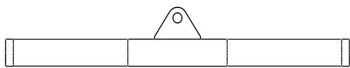
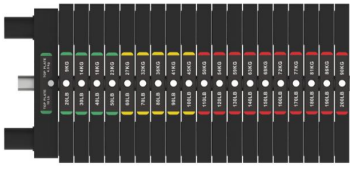

Important Information : To ensure optimal performance and longevity of this rack, we highly recommend a regular maintenance routine, including the application of silicone oil every three to four months. This simple step will effectively lubricate all moving parts, ensuring seamless functionality and prolonged durability.

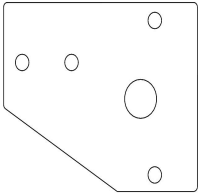
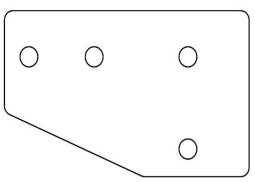
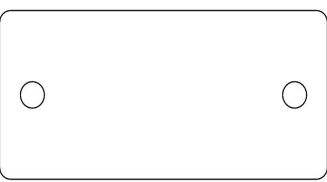

Packing List-1

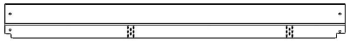
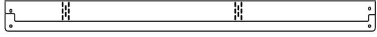
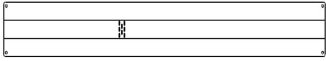
					
NO.1	Functional trainer left pulley*1pc	NO.2	Functional trainer right pulley*1pcs*1pc	NO.3	Rear column welding group*1pc
					
NO.4	Left base welding group*1pc	NO.5	Right base welding group*1pc	NO.6	Right top welding group*1pc
					
NO.7	Left top welding group*1pc	NO.8	Beam as-upper*1pc	NO.9	Storage riser welding group*1pc
					
NO.10	Lifting pulley assembly right*1pc	NO.11	Lifting pulley assembly left*1pc	NO.12	Cast iron counterweight*2pcs
					
NO.13	Push rod welding group*1pc	NO.14	Low tension welding group*1pc		Stack weight stickers*1pc

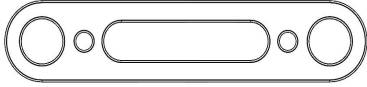
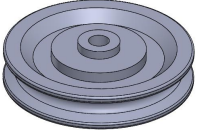
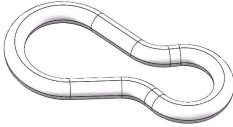
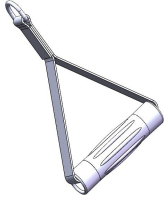
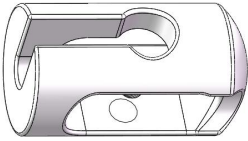
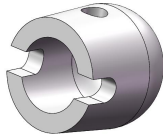
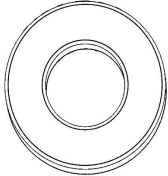
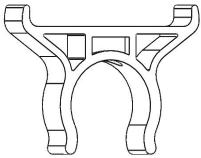
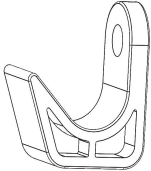
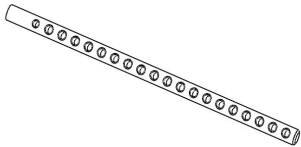
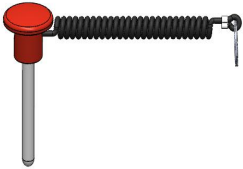
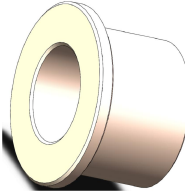
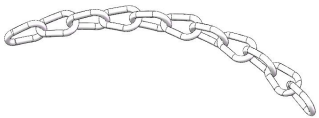
Packing list-2

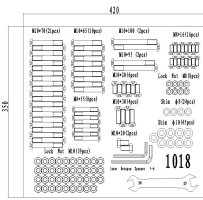
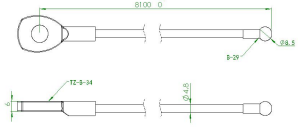
					
No.15	Upper assembly board * 4 pcs	No.16	Lower assembly board * 4 pcs	No.17	Small assembly board * 2 pcs

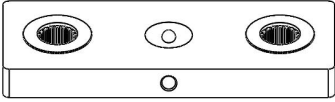
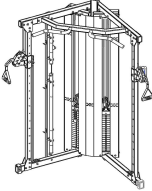
					
No.18	Stainless steel lettering tube*2 pcs	No.19	Side guard left *1 pc	No.20	Side guard plate right*1 pc
					
No.21	Front guard plate *1	No.22	Guide rod Ø25*2.0*1818*4件	No.23	Optical axis fixed block * 2 pcs
					
No.24	Φ90 pulley*10 pcs	No.25	Safety hook * 4 pcs	No.26	Low pull handle*2 pcs
					
No.27	Card slot set * 2 pcs	No.28	Rubber cover*2 pcs	No.29	Round shock cushion * 4 pcs
					
No.30	Clip set * 4 pcs	No.31	Plastic hook * 6 pcs	No.61	Center rod 20 holes * 2 pcs
					
No.33	Φ10*100 counterweight bolt*2 pcs	No.34	Pulley limit set * 20 pcs	No.35	Chain 0.35m*2 pcs
				 Φ4. 8*8100mm 2pcs for machine, in one package	
No.55	Biceps*1 pc	No.56	Blister pack*1 pc	No.57	Wire rope*2 pcs

					
No.58	Weight piece * 38 pcs	No.59	Manual *1	No.60	Foot pocket *1
					
Black warning label*2					

Blister Pack Screw List-3

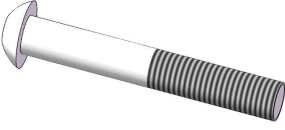
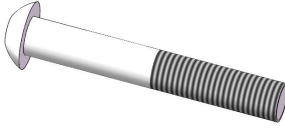
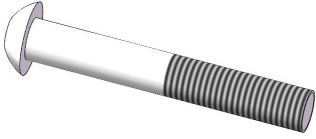
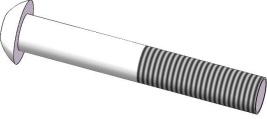
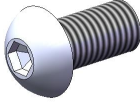
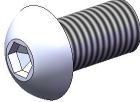
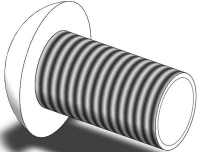
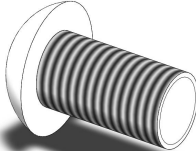
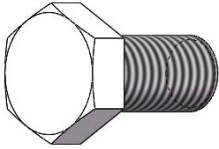
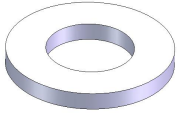
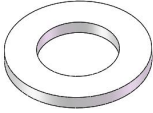
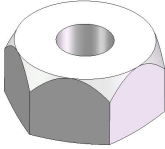
					
A	Hexagon socket flat head screw M10*100 *2pcs	B	Hexagon socket flat head screw M10*95* 2pcs	C	Hexagon socket flat head screw M10*70 *23pcs
					
D	Hexagon socket flat head screw M10*65 *10 pcs	E	Hexagon socket flat head screw M10*30 * 4pcs	F	Hexagon socket flat head screw M10*20 *6pcs
					
G	Hexagon socket flat head screw M8*20 *10pcs	H	Hexagon socket flat head screw M8*16 *12pcs	I	M10*20 external hexagon screw*2pcs
					
J	Flat gasket Ø10 *45pcs	K	Flat gasket Ø8 *12pcs	M	M10 lock nut *39pcs