

WLC-SML

Wet Location Combo Light

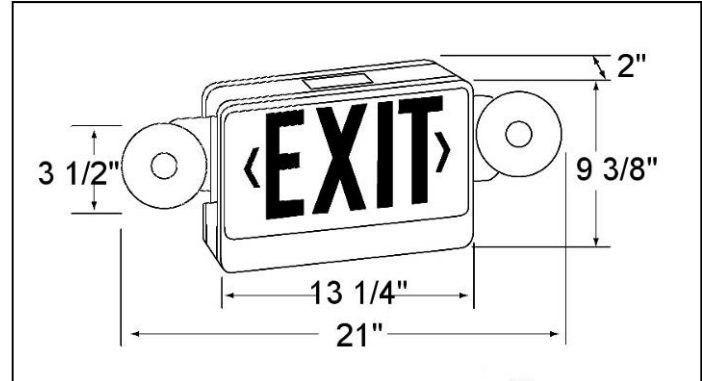

GENERAL DESCRIPTION

Two head exit / emergency light for wet location.

MAIN FEATURES

Listing

- ETL listed for wet location.

Voltage

- Dual 120/277V
- Field selectable.

Lamps / Heads

- Exit
 - LED
 - Energy consumption: 2 watts for red letters and 1 watt for green letters.
 - Estimated 25 year life
- Emergency
 - 2 x 6V, 7W MR16 (included)
 - Adjustable

Operating Temperature

- -10°C (14°F) to 40°C (104°F).

Battery

- Two
- 6V, 2.3 amp
- Lead-calcium
- Rechargeable
- Protected from deep discharge by automatic low voltage disconnect circuitry.
- Expected life: 10 years.
- Whenever normal AC current fails, the internal solid state transfer switch automatically connects the internal battery to the fixture to keep the sign continuously lit for at least 90 minutes.

Housing

- UV fiberglass
- Corrosion resistant
- Single face
- Universal snap-in and out chevron design meets all state and local codes (UL924)

Mounting

- Wall

Finish / Color Options

- Green letters, white housing
- Red letters, white housing

Replacement Items

- Battery: RB-3.
- Lamp: RBL-4.

Other Features

- Integral recharging system.
- Fully automatic operation.
- Completely self contained.
- Sealed momentary test switch.
- AC ready light.
- AC lockout feature reduces installation time.
- Limited 5 year warranty.

Project:
Contact:
Location:
Fixture Type:

Quantity	Remarks