

RHLED Indoor LED Remote Head

Project:	
Type:	
Catalog #:	



ILLUMINATION

- Long lasting, efficient, ultra bright white LED lamp heads.
- High performance chrome-plated metallized reflector and plastic lens with 8 or 12 LED's in each lamp head for optimal light distribution.
- Adjustable LED lamp heads increases center-to-center spacing.

ELECTRICAL

- Powered from low voltage power source with low voltage wiring (not provided).

MOUNTING

- Universal mounting base plate included with mounting hardware.
- Distance of maximum run is determined by system voltage, wire gauge and total maximum wattage on the run.
- Suitable for wall or ceiling mount.

HOUSING

- Injection-molded, engineering grade, 5VA flame retardant, high-impact resistant, thermoplastic in white or black finish.

WARRANTY / LISTING

- Five year warranty.
- UL Listed with approved Best Lighting Products.
- Meets UL924, NFPA 101 Life Safety Code, NEC, OSHA, Local and State Codes.

DIMENSIONS

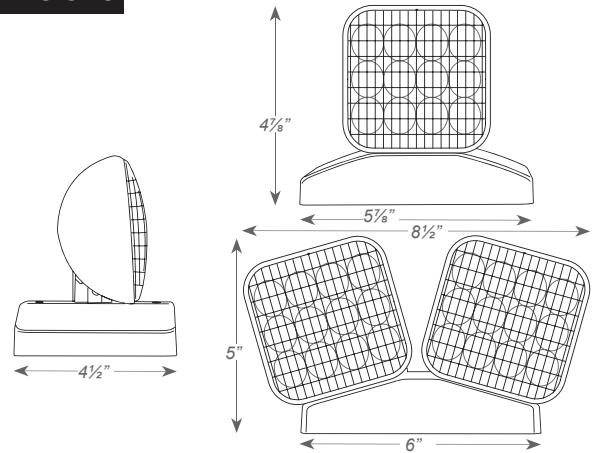

FIXTURE COMPATIBILITY CHART

Reference individual unit equipment specification sheets for remote load capacity availability.

MODEL TYPE	3.6V	9.6V	MV
LEDXTEU-RC		X	X
CLPU-RC		X	X
CKXTEU-RC	X		X
LEDR-5HO	X		X
LEDTFX-2		X	X
E-1-RC	X		X
CEU-RC	X		X

ORDERING INFORMATION

Sample Part Number: **RHLED-2**

MODEL	No. of HEADS	OPTIONS		VOLTAGE	COLOR	LAMP TYPE ¹
RHLED	1	Single Head	Blank	3.6V	Blank	8 LEDs 1W
	2	Double Head	SDT	9.6V	B	HL
				MV		

For Standard non-self-diagnostic fixtures
For use with fixtures with a self-diagnostic option
For use with 3.6V batteries
For use with 9.6V batteries
For use with 3.6V, 6V, 9.6V & 12V batteries

Notes:

1. Wattage rating stated per head.